

200

Wire Antennas

For

Ham Radio

Julian Rosu YO3DAC / VA3IUL,

01 - Tee Antenna
02 - Half-Lambda Tee Antenna
03 - Twin-Led Marconi Antenna
04 - Swallow-Tail Antenna
05 - Random Length Radiator Wire Antenna
06 - Windom Antenna
07 - Windom Antenna - Feed with coax cable
08 - Quarter Wavelength Vertical Antenna
09 - Folded Marconi Tee Antenna
10 - Zeppelin Antenna
11 - EWE Antenna
12 - Dipole Antenna - Balun
13 - Multiband Dipole Antenna
14 - Inverted-Vee Antenna
15 - Sloping Dipole Antenna
16 - Vertical Dipole
17 - Delta Fed Dipole Antenna
18 - Bow-Tie Dipole Antenna
19 - Bow-Tie Folded Dipole Antenna for RX
20 - Multiband Tuned Doublet Antenna
21 - G5RV Antenna
22 - Wideband Dipole Antenna
23 - Wideband Dipole for Receiving
24 - Tilted Folded Dipole Antenna
25 - Right Angle Marconi Antenna
26 - Linearly Loaded Tee Antenna
27 - Reduced Size Dipole Antenna
28 - Doublet Dipole Antenna
29 - Delta Loop Antenna
30 - Half Delta Loop Antenna
31 - Collinear Franklin Antenna
32 - Four Element Broadside Antenna

101 - Dual Polarization Antenna for 80m and 40m
102 - Directive 300-ohm-Ribbon Folded Dipole for 15m
103 - Miniature Directive Antenna for 10m
104 - Biquad Antenna 12dBi-Gain for 2.4GHz
105 - Dual-Rhomboid Antenna for 435MHz to 870MHz
106 - Double-Bazooka Antenna for 80m
107 - J-Style Antenna
108 - Vertical / Horizontal / Circular Polarization Antenna
109 - Coax Inverted-L Antenna for 80m
110 - Indoor Compact Loop Antenna for 80m
111 - Helix Antenna
112 - Novice Vertical Antenna for 80m, 40m, 15m, 10m
113 - Stub-Loaded Shortened Dipole for 80m
114 - Six-Band Wire-Stub Trap Antenna for 40m-10m
115 - Multiband Half-Wave Delta-Loop Antenna
116 - Hybrid Vee for 20m, 17m
117 - Six-Shooter Array Antenna, Gain=7.5dB
118 - Multiband Ground-Plane Antenna for 10m, 15m, 20m
119 - Wire Superbeam Antenna for 10m, 15m, 20m
120 - Two Elements Delta-Loop Antenna
121 - Sterba Curtain Antenna
122 - Half-Wave Vertical Zepp Antenna
123 - Lazy-Loop Antenna for 40m
124 - Terminated Folded Dipole for 80m, 40m
125 - Short-Fat Antenna for 15m
126 - Cobra Antenna for 80m
127 - Log-Periodic Wire Antenna for 20m, 15m, 10m

<u>33 - The Lazy-H Array Antenna</u>	<u>128 - 5-Element Log-Periodic Vertical Antenna for 80m, 40m, 20m</u>
<u>34 - Sterba Curtain Array Antenna</u>	<u>129 - 2m Vertical Wire Antennas</u>
<u>35 - T-L DX Antenna</u>	<u>130 - Earth-Mover Inverted-V Antenna for 40m</u>
<u>36 - 1.9 MHz Full-wave Loop Antenna</u>	<u>131 - Coax-Cable Collinear Antennas</u>
<u>37 - Multi-Band Portable Antenna</u>	<u>132 - Double Bobtail Antenna for 20m</u>
<u>38 - Off-center-fed Full-wave Doublet Antenna</u>	<u>133 - Collinear Zepp Antenna</u>
<u>39 - Terminated Sloper Antenna</u>	<u>134 - Taylor Vee Antenna for 20m</u>
<u>40 - Double Extended Zepp Antenna</u>	<u>135 - Collinear Vertical Antenna 6dB-Gain for 2m, 1.3m, 73cm</u>
<u>41 - TCFTFD Dipole Antenna</u>	<u>136 - Bi-Loop Antenna for 20m</u>
<u>42 - Vee-Sloper Antenna</u>	<u>137 - Wire Beam 6dBd-Gain for 10m</u>
<u>43 - Rhombic Inverted-Vee Antenna</u>	<u>138 - Sloping Diamond Antenna 4dB-Gain for 40m</u>
<u>44 - Counterpoise Longwire</u>	<u>139 - Twisted Loop Antenna for 160m</u>
<u>45 - Bisquare Loop Antenna</u>	<u>140 - DX RX Loop Antenna for 160m</u>
<u>46 - Piggyback Antenna for 10m</u>	<u>141 - Hentenna 3dB-Gain for 10m, 6m, 2m</u>
<u>47 - Vertical Sleeve Antenna for 10m</u>	<u>142 - VK2AAR Wire Antenna for 20m</u>
<u>48 - Double Windom Antenna</u>	<u>143 - 2-Elements Quad Antenna for 6m</u>
<u>49 - Double Windom for 9 Bands</u>	<u>144 - Hula-Loop Bidirectional 6dB-Gain Antenna for 17m</u>
<u>50 - Collinear Trap Antenna</u>	<u>145 - Moxon Rectangle Beam for 15m-10m</u>
<u>51 - Short Dipole Antenna for 40m - 80m - 160m</u>	<u>146 - Double-D Beam 4dB-Gain</u>
<u>52 - Center Fed-Zepp Antenna for 80m - 40m</u>	<u>147 - KE4PT OCEF All-Band Dipole</u>
<u>53 - All Bands Antenna</u>	<u>148 - Wire Quad Antenna for 40m</u>
<u>54 - All-Bands Dipole Antenna</u>	<u>149 - Inclined Dipole Antenna for 80m, 40m</u>
<u>55 - Multiband Z Antenna</u>	<u>150 - Pyramidal Wire Antenna for 80m</u>
<u>56 - Multiband Dipole Antenna</u>	<u>151 - Random Wire Antenna All Bands</u>
<u>57 - Five-Bands No-Tuner Antenna</u>	<u>152 - Multiband Dipole Antenna for 80m, 40m, 15m, 10m</u>
<u>58 - Dualband Full-wave Loop Antenna for 80m-40m</u>	<u>153 - Slim Jim Wire Antenna for 4m</u>
<u>59 - Loop Antenna for 10m</u>	<u>154 - Delta Loop for 6m</u>
<u>60 - Lazy Quad Antenna for 10m</u>	<u>155 - Re-Configurable Antenna for 160m and 80m</u>
<u>61 - Tri-band Delta Loop Antenna for 80m - 40m - 30m</u>	<u>156 - Very Low Frequency Inverted-L Antenna</u>
<u>62 - Dual-band Loop Antenna for 30m - 40m</u>	<u>157 - Reduced Size Half Sloper Antenna for 160m</u>
<u>63 - Wire-Beam Antenna for 80m</u>	

<u>64 - Dual-Band Sloper Antenna</u>	<u>158 - Tree-Mounted HF Antenna</u>
<u>65 - Inverted-V Beam Antenna for 30m</u>	<u>159 - Multiband Vertical Antenna for 80m, 40m, 20m</u>
<u>66 - ZL-Special Beam Antenna for 15m</u>	<u>160 - Marconi Antenna for 136 kHz</u>
<u>67 - Half-Sloper Antenna for 160m</u>	<u>161 - Simple Killer Antenna for 40m</u>
<u>68 - Two-Bands Half Sloper for 80m - 40m</u>	<u>162 - Stub-Directed V Antenna for 80m</u>
<u>69 - Linear Loaded Sloper Antenna for 160m</u>	<u>163 - KT0NY Over-and-Under DX Antenna for 20m</u>
<u>70 - Super-Sloper Antenna</u>	<u>164 - Horizontal Loop Antennas</u>
<u>71 - Tower Pole as a Vertical Antenna for 80m</u>	<u>165 - Ribbon J-Pole for 2m</u>
<u>72 - Clothesline Antenna</u>	<u>166 - Dual Band Ribbon J-Pole for 2m, 70cm</u>
<u>73 - Curtain Zepp Antenna for 160m, 80m, 40m</u>	<u>167 - Square Vertical Loop Antenna for 40m</u>
<u>74 - Collinear Array Antenna for 40m, 30m, 20m</u>	<u>168 - Tri-Band Quad Antenna for 20m, 15m, 10m</u>
<u>75 - 160m Inverted Delta Loop</u>	<u>169 - 3D Quad Antenna for 80m, 40m, 20m, 15m, 10m</u>
<u>76 - Half Rhombic Unidirectional Vertical for 20m to 6m</u>	<u>170 - Sloping Wire Antenna for 30m, 20m, 17m, 15m, 12m, 10m</u>
<u>77 - Capacitance Loaded Vertical Antenna for 160m</u>	<u>171 - Broadband Dipole Antenna with Coaxial Resonator for 80m</u>
<u>78 - Fan Dipole Antenna for 80m to 6m</u>	<u>172 - Resonant Feedline Dipole Antenna for 80m</u>
<u>79 - Wire Ground Plane Antenna</u>	<u>173 - Dual-Band Loading Wire Antenna for 80m, 30m</u>
<u>80 - Inverted Delta Loop Antenna for 160m</u>	<u>174 - Stub Matching Antennas</u>
<u>81 - Inverted-L for 160m</u>	<u>175 - J-Style Vertical Wire Antenna for 10m</u>
<u>82 - 300ohm-Ribbon Dual Band Dipole</u>	<u>176 - Dual Band Vertical with Zepp Feeders for 40m, 20m</u>
<u>83 - Tri-Band Beam for 20m, 15m, 10m</u>	<u>177 - RCA Double Doublet for 40m to 12m</u>
<u>84 - Mini-Horse Yagi Antenna</u>	<u>178 - RCA Spiderweb Antenna for 40m to 6m</u>
<u>85 - Backpack J-Pole Antenna for 10m, 6m, 2m</u>	<u>179 - Folded Dipole with Shorted Straps</u>
<u>86 - Fan-Dipole Antenna for 80m, 40m, 20m</u>	<u>180 - Twin-Lead Marconi Antenna for 160m, 80m</u>
<u>87 - Capacity Tuned Folded Loop Antenna for 20m</u>	<u>181 - Broadband Antenna Quarter-Wave Balun for 80m</u>
<u>88 - Indoor Loop Antenna for 80m to 30m</u>	<u>182 - Three-Quarter-Wave Folded Doublet for Dual-Band</u>

<p><u>89 - Indoor Loop Antenna for 80m</u></p> <p><u>90 - Double-Delta Antenna 80m and 40m</u></p> <p><u>91 - Inductance-Loaded Shortened Dipole for 160m</u></p> <p><u>92 - V-Beam Antenna for 15m</u></p> <p><u>93 - Picnic Vertical Wire Antenna</u></p> <p><u>94 - Laid-Back Quad Antenna for 80m</u></p> <p><u>95 - Phased Loop Antenna</u></p> <p><u>96 - Loop Antenna for TX for 160m</u></p> <p><u>97 - Morgain-Dipole Antenna for 160m and 80m</u></p> <p><u>98 - ZL-Special for 20m, 15m, 10m</u></p> <p><u>99 - Biconical Antenna</u></p> <p><u>100 - Directive Delta-Birdcage Antenna for 20m to 10m</u></p>	<p><u>183 - Three-Quarter-Wave Folded Doublet No-Switch for Dual-Band</u></p> <p><u>184 - Wideband Omni-Directional Discone Antenna</u></p> <p><u>185 - Wideband Rhombic Antenna for 40m to 10m</u></p> <p><u>186 - Pre-Cut Linear Array Antenna 3dB-Gain for 40m</u></p> <p><u>187 - X-Array Antenna 6dB-Gain for 20m, 15m, 10m</u></p> <p><u>188 - Double-Bruce Array Antenna 5dB-Gain for 20m, 10m</u></p> <p><u>189 - Bi-Square Broadside Array Antenna 4dB-Gain for 20m, 15m, 10m</u></p> <p><u>190 - Six-Shooter Broadside Array Antenna 7.5dB-Gain for 20m, 15m, 10m</u></p> <p><u>191 - Triplex Flat-Top Beam 4.5dB-Gain for 20m, 15m, 10m</u></p> <p><u>192 - Dual-Band Tilt Antenna for 20m, 10m</u></p> <p><u>193 - Super Space Multiband Dipole Antenna for 80m to 10m</u></p> <p><u>194 - Bi-Square Beam Antenna Gain=5.5dB for 10m</u></p> <p><u>195 - Cousin of G5RV Multiband Antenna for 40m to 10m</u></p> <p><u>196 - Cayman Quad Antenna for 20m</u></p> <p><u>197 - Hentenna Gain=3dB with Bazooka Match for 6m</u></p> <p><u>198 - X-Beam Antenna Gain=3dB for 20m</u></p> <p><u>199 - Twin Delta Loop Antenna Gain=6dB for 160m, 80m, 40m</u></p> <p><u>200 - Inverted-V Beam Antenna for 30m</u></p>
--	--

01 - Tee Antenna

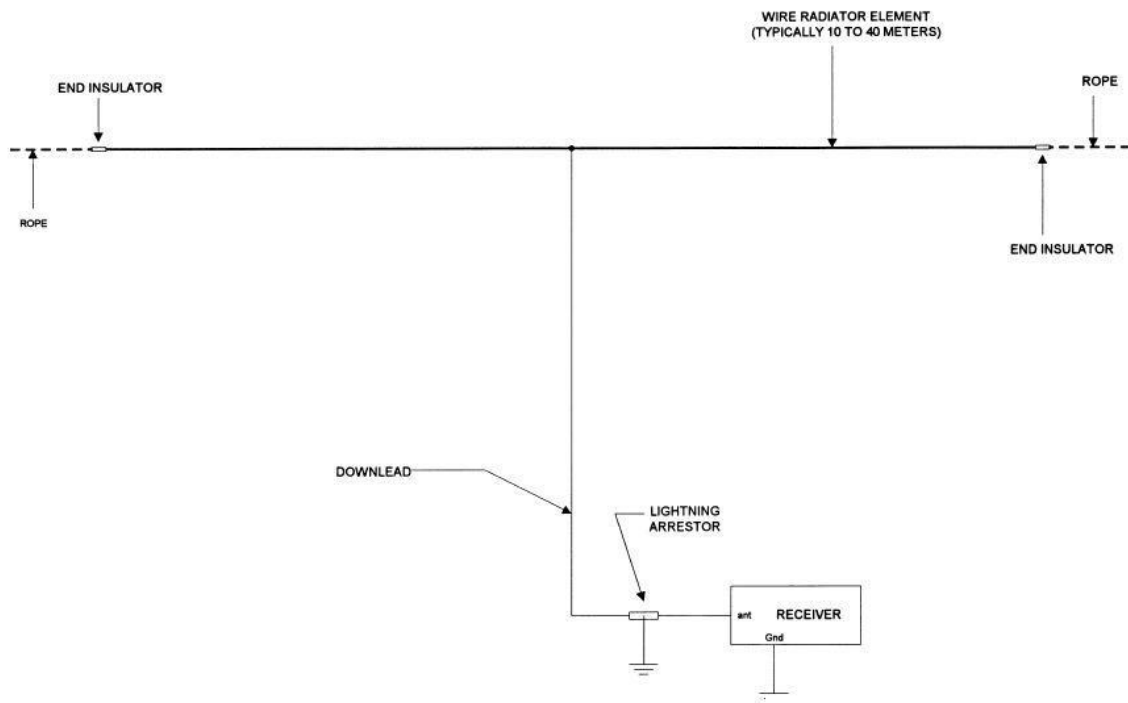

02 - Half-Lambda Tee Antenna

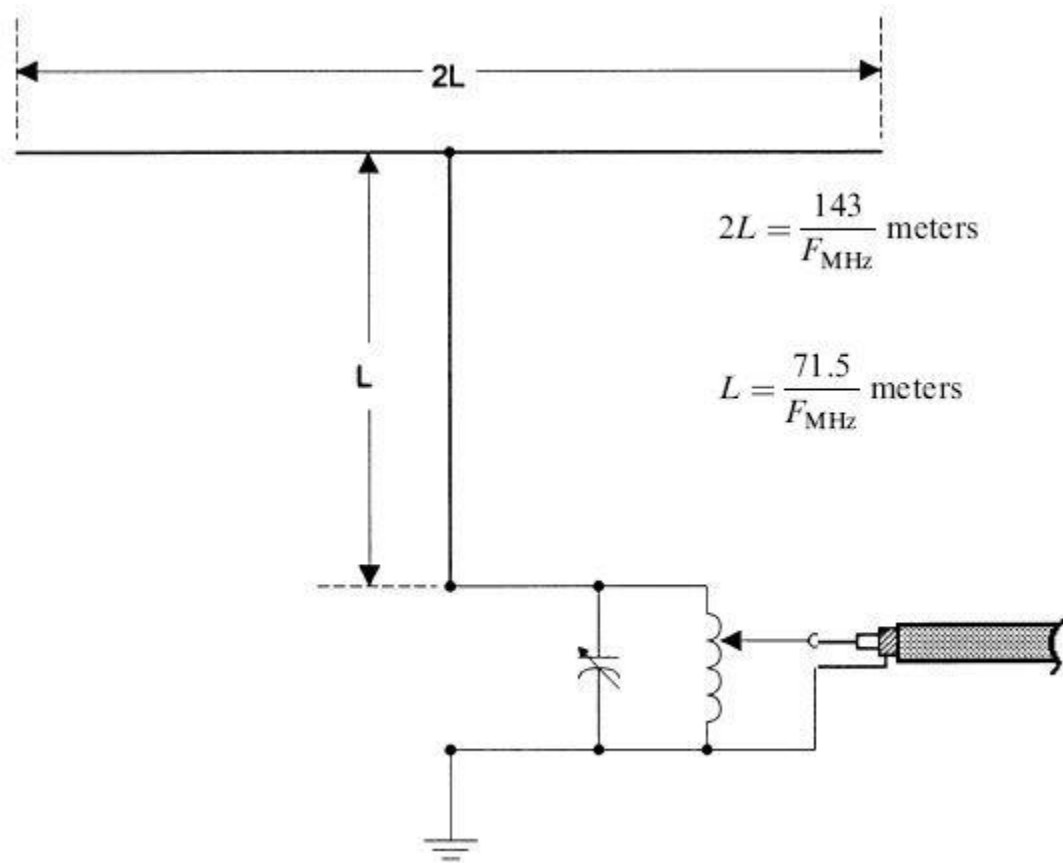

03 - Twin-Led Marconi Antenna

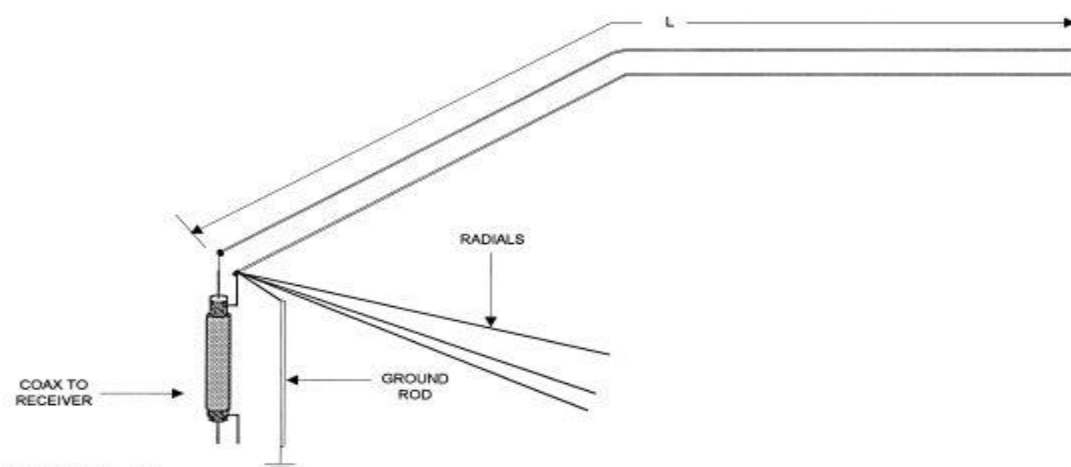

04 - Swallow-Tail Antenna

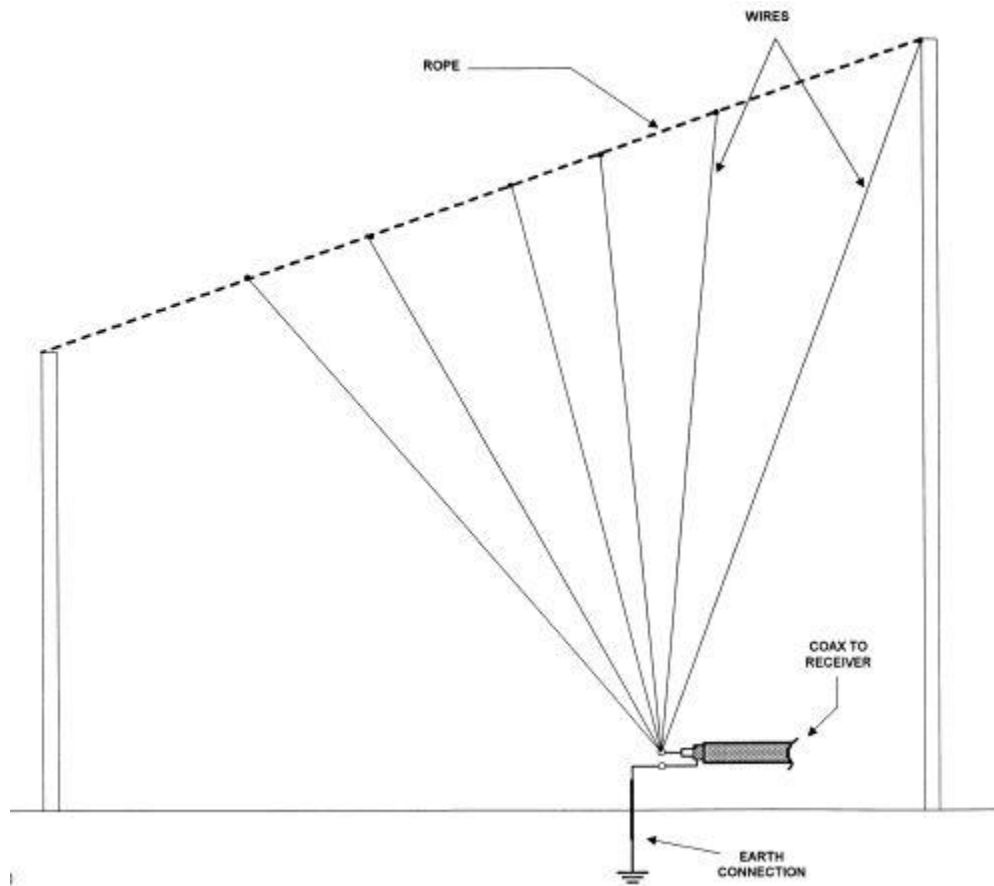

05 - Random Length Radiator Wire Antenna

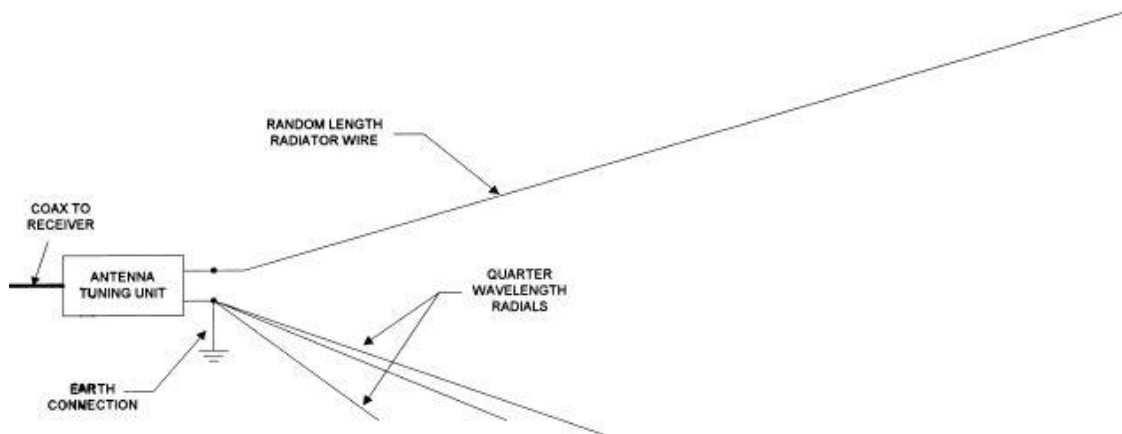

06 - Windom Antenna

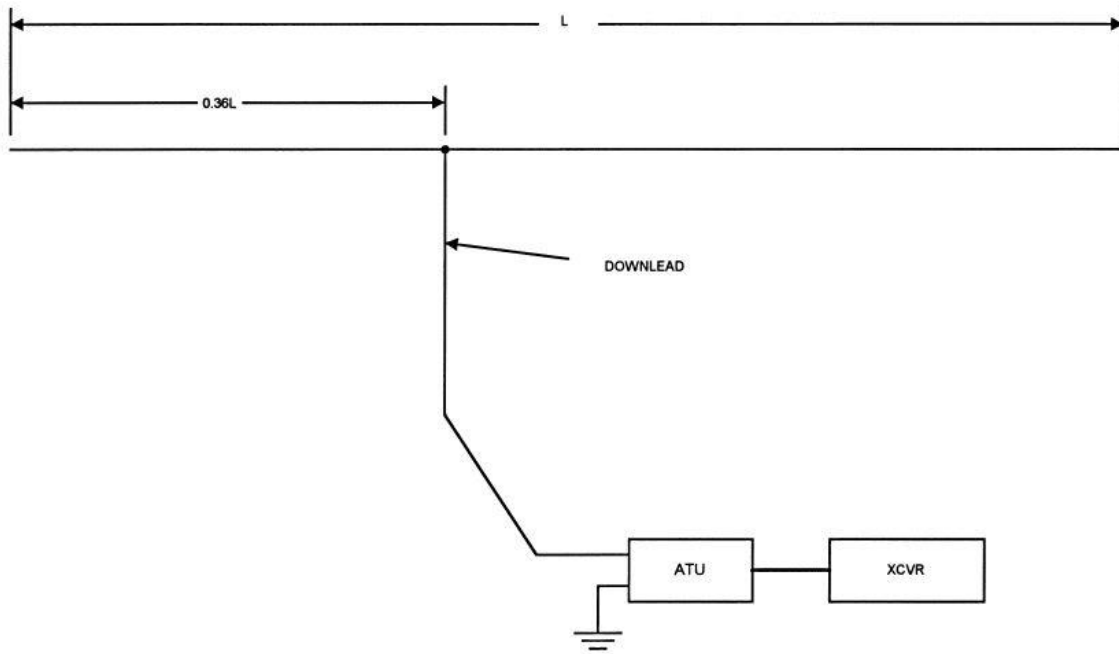

07 - Windom Antenna - Feed with coax cable

08 - Quarter Wavelength Vertical Antenna

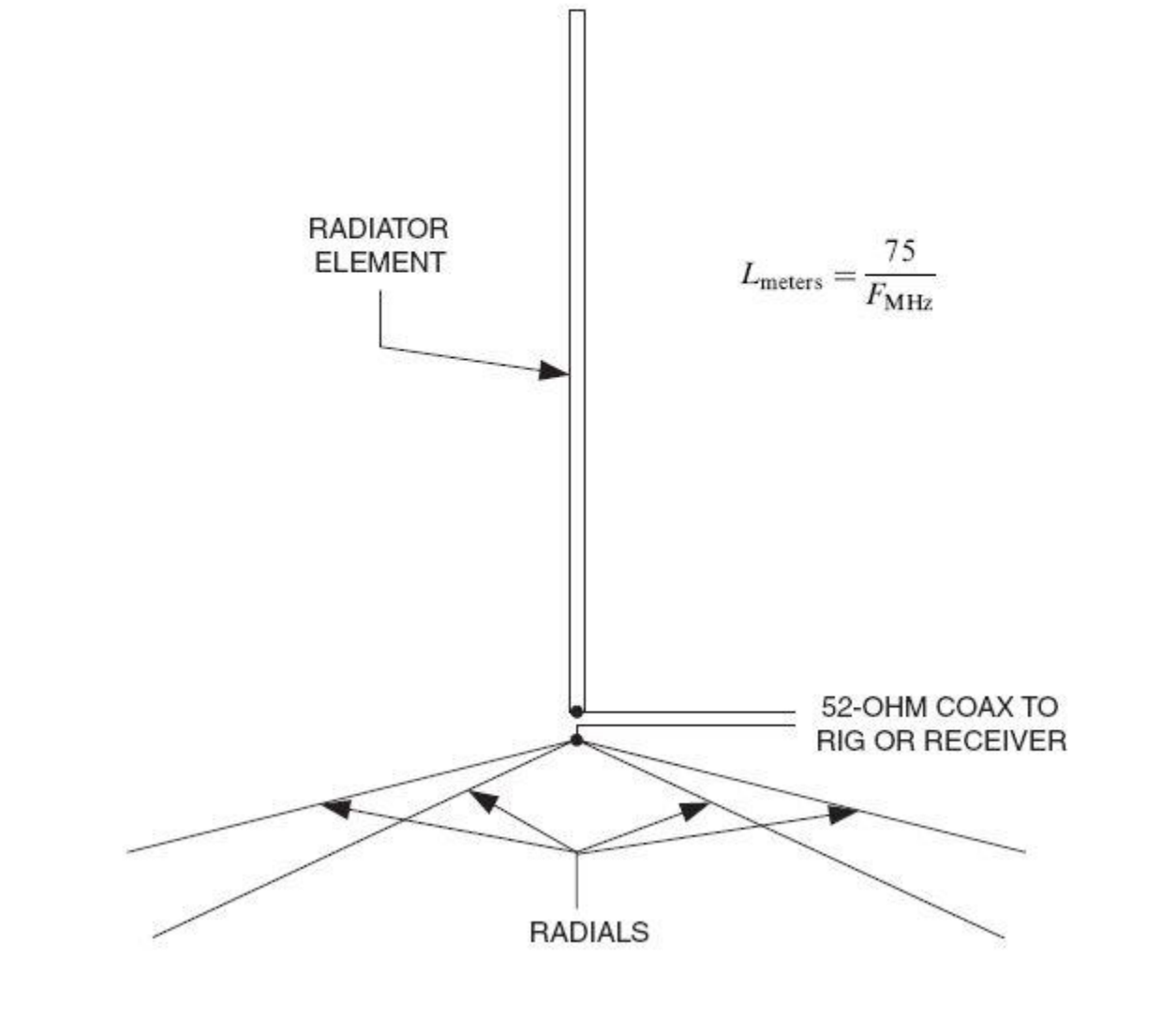

09 - Folded Marconi Tee Antenna

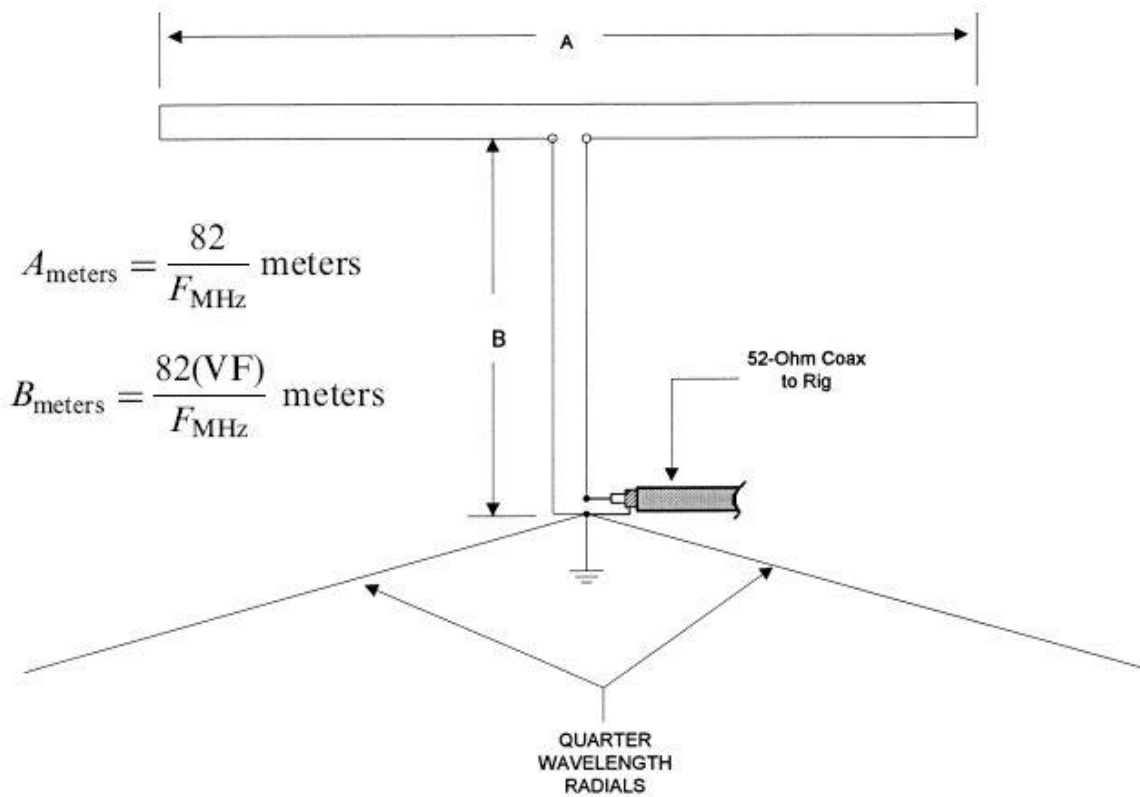

10 - Zeppelin Antenna

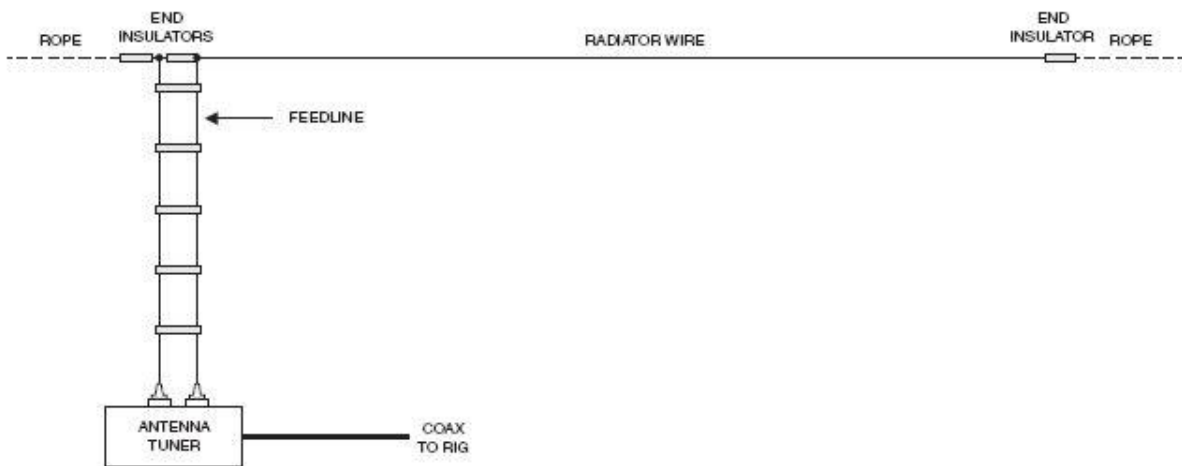

11 - EWE Antenna

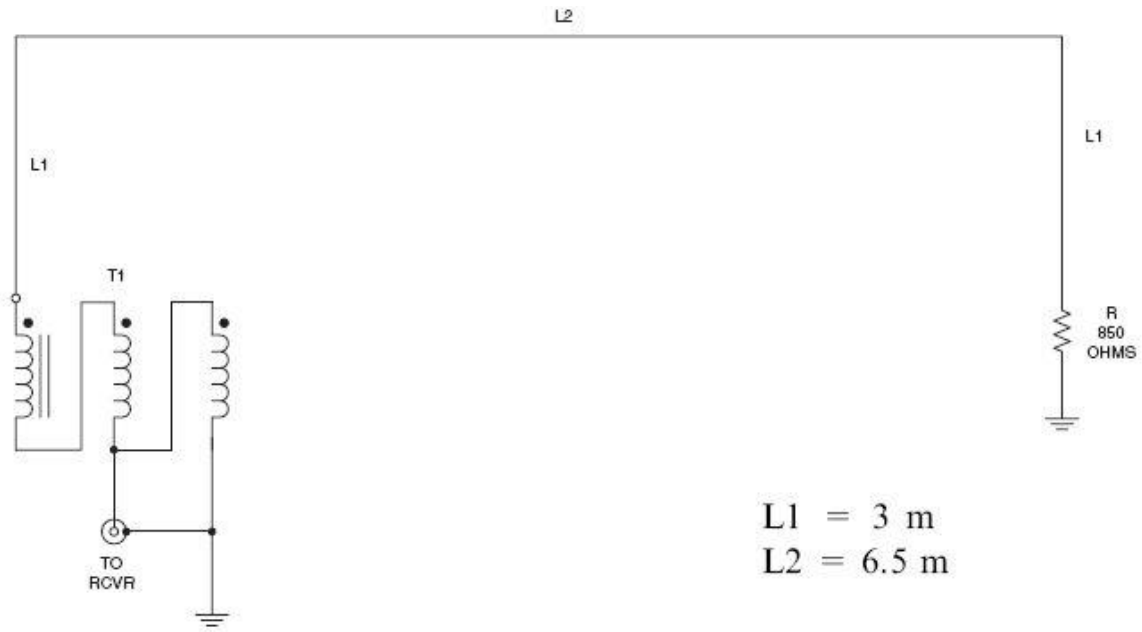

12 - Dipole Antenna - Balun

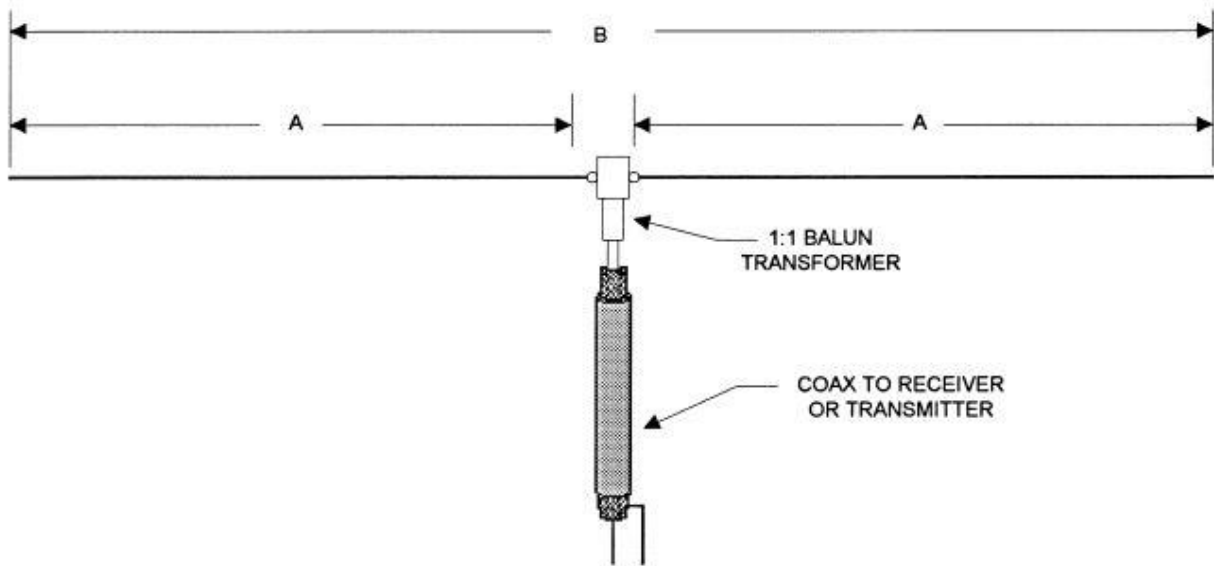

13 - Multiband Dipole Antenna

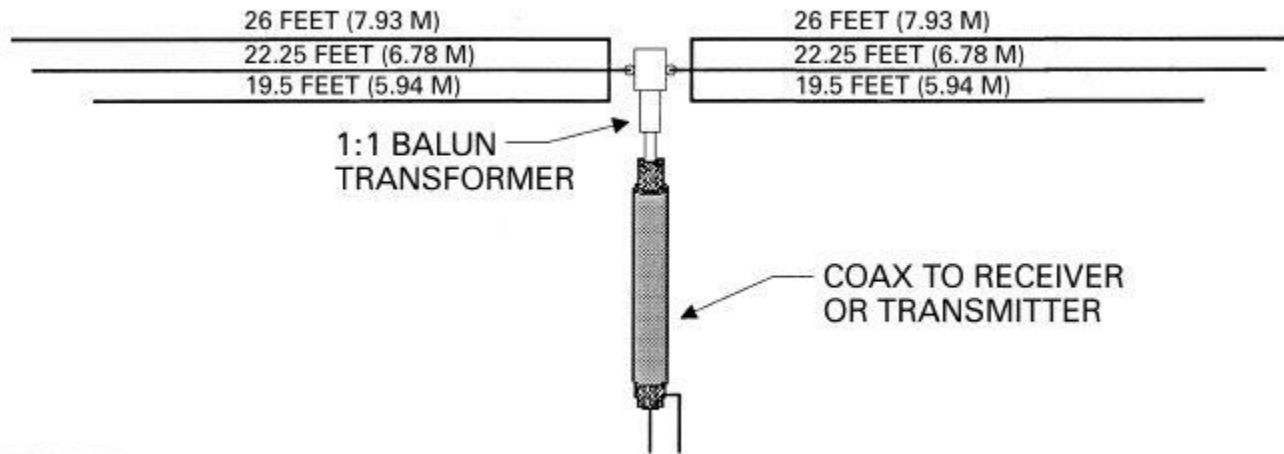

14 - Inverted-Vee Antenna

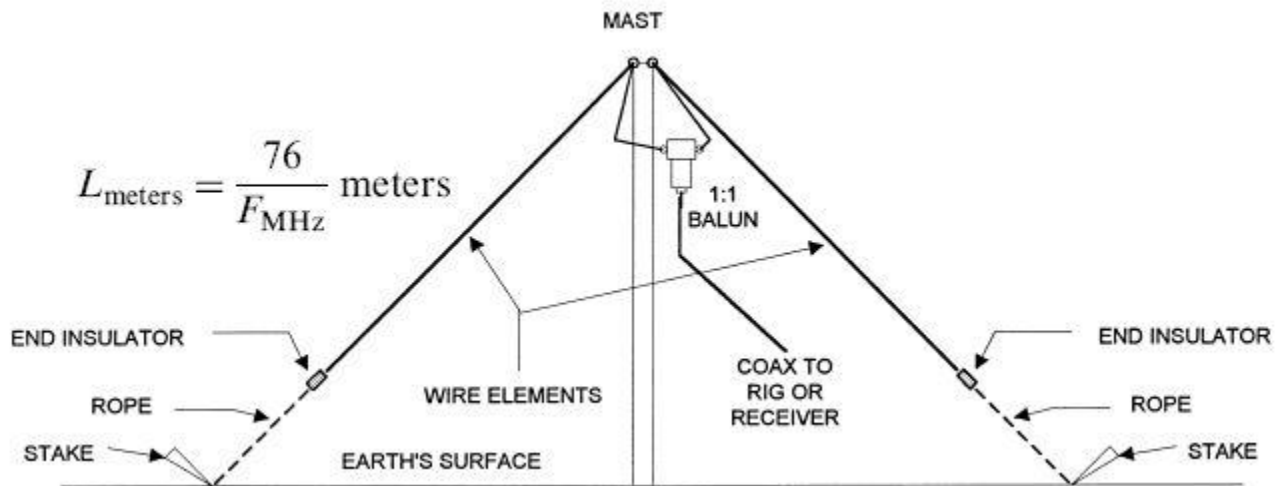

15 - Sloping Dipole Antenna

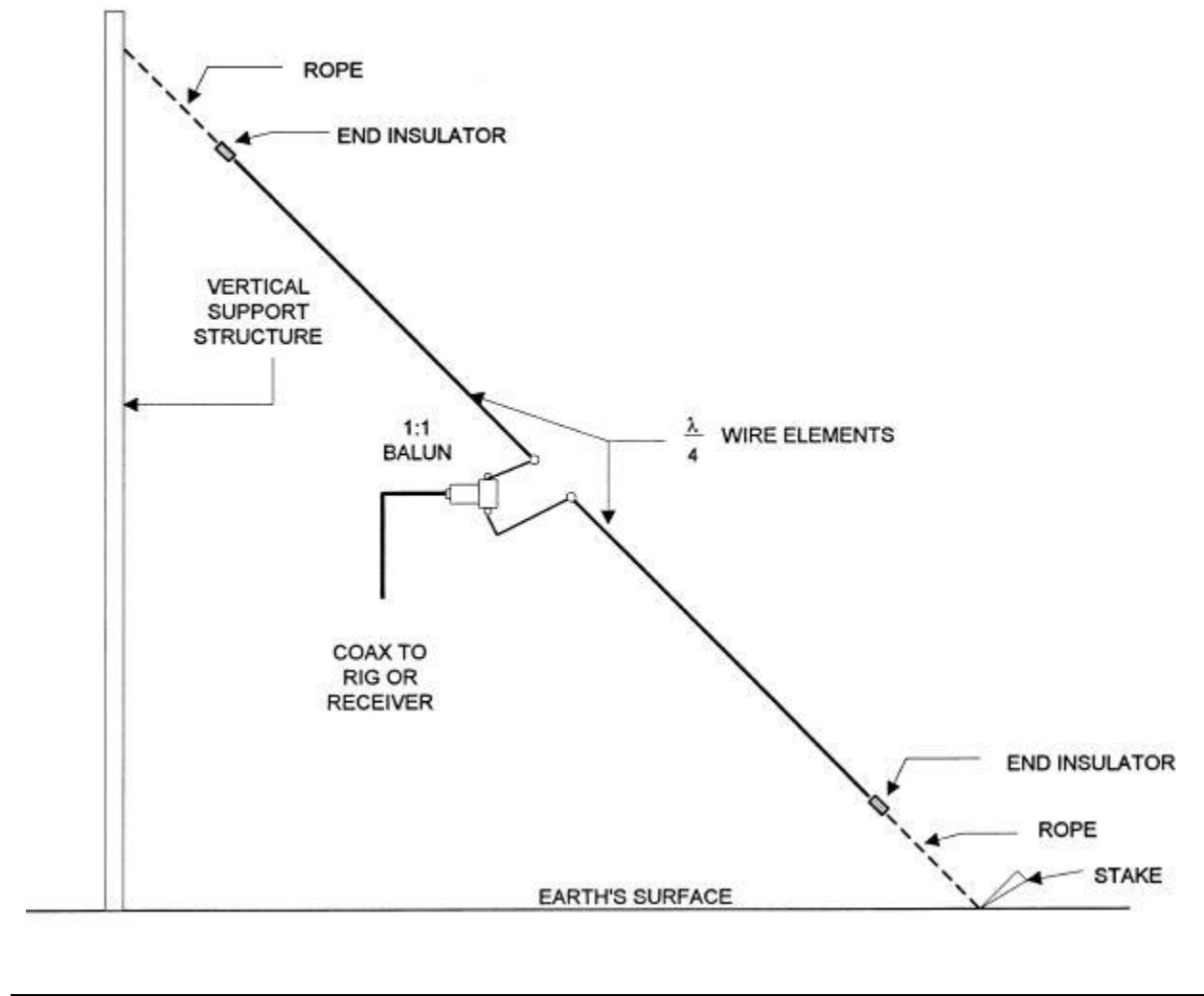

16 - Vertical Dipole

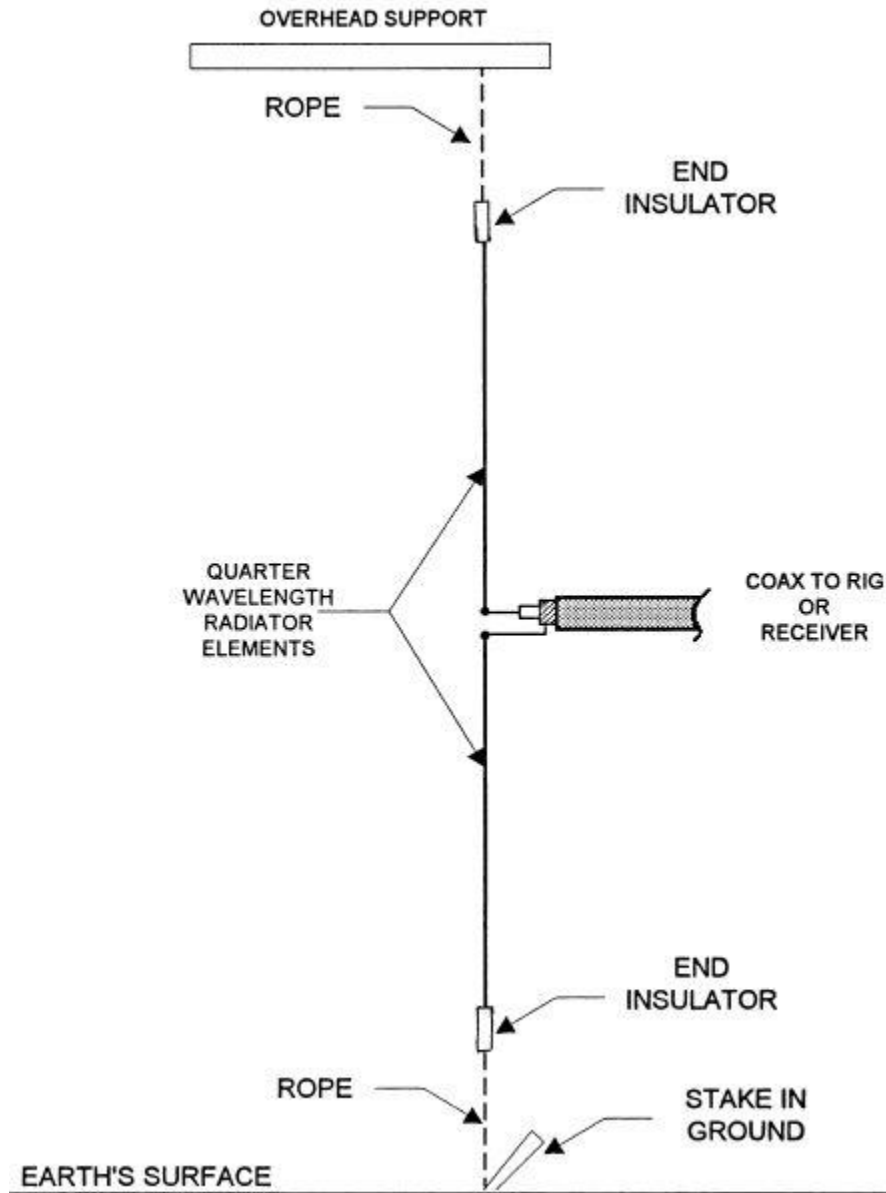

17 - Delta Fed Dipole Antenna

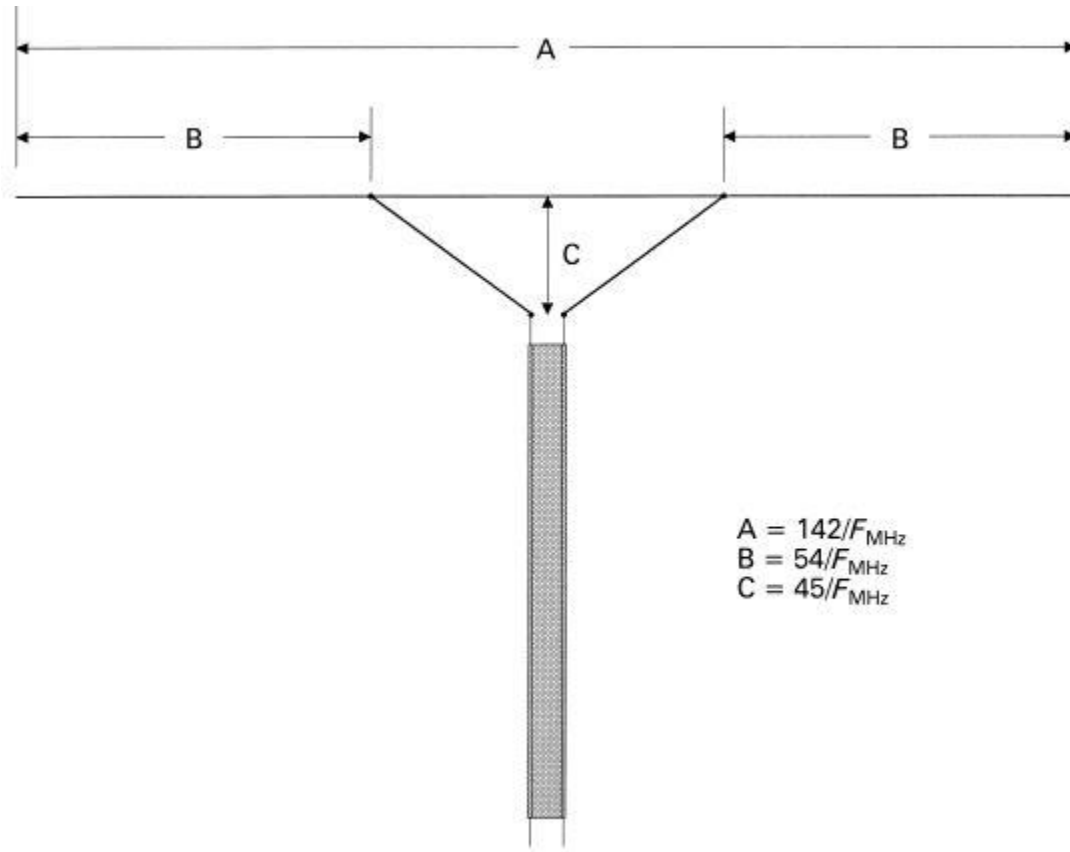

18 - Bow-Tie Dipole Antenna

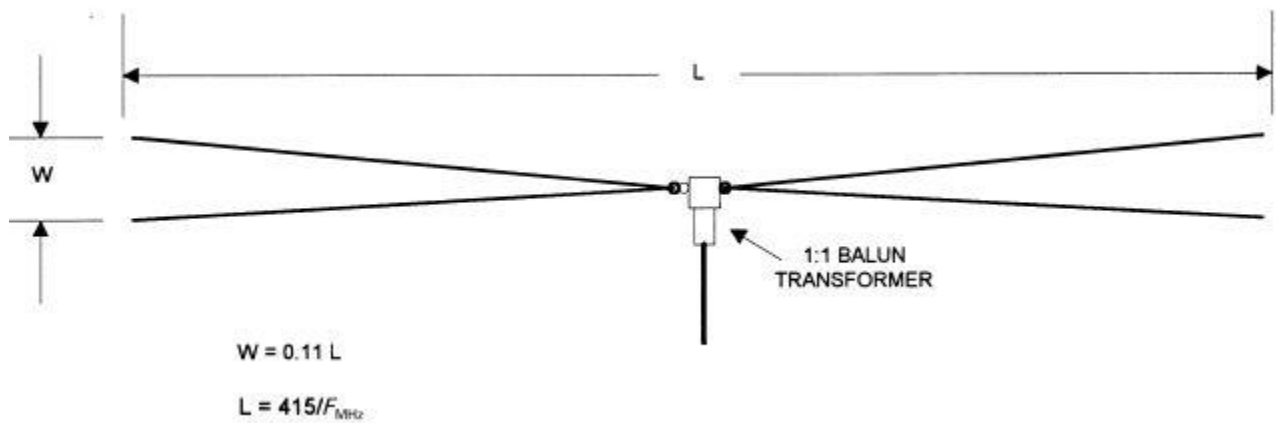

19 - Bow-Tie Folded Dipole Antenna for RX

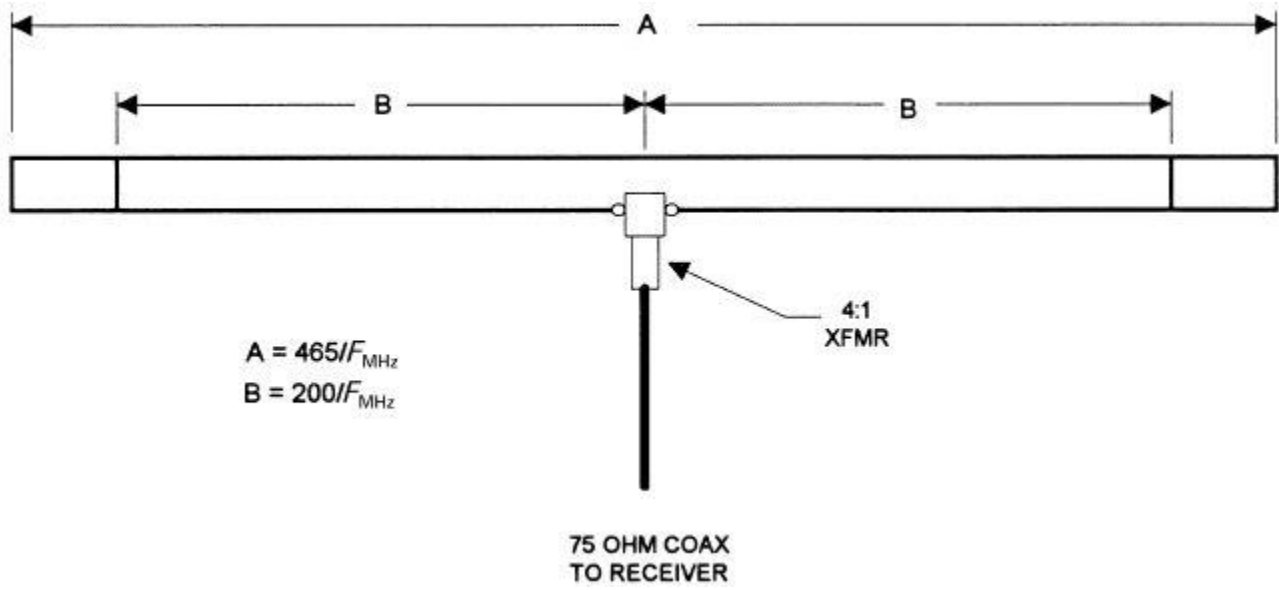

20 - Multiband Tuned Doublet Antenna

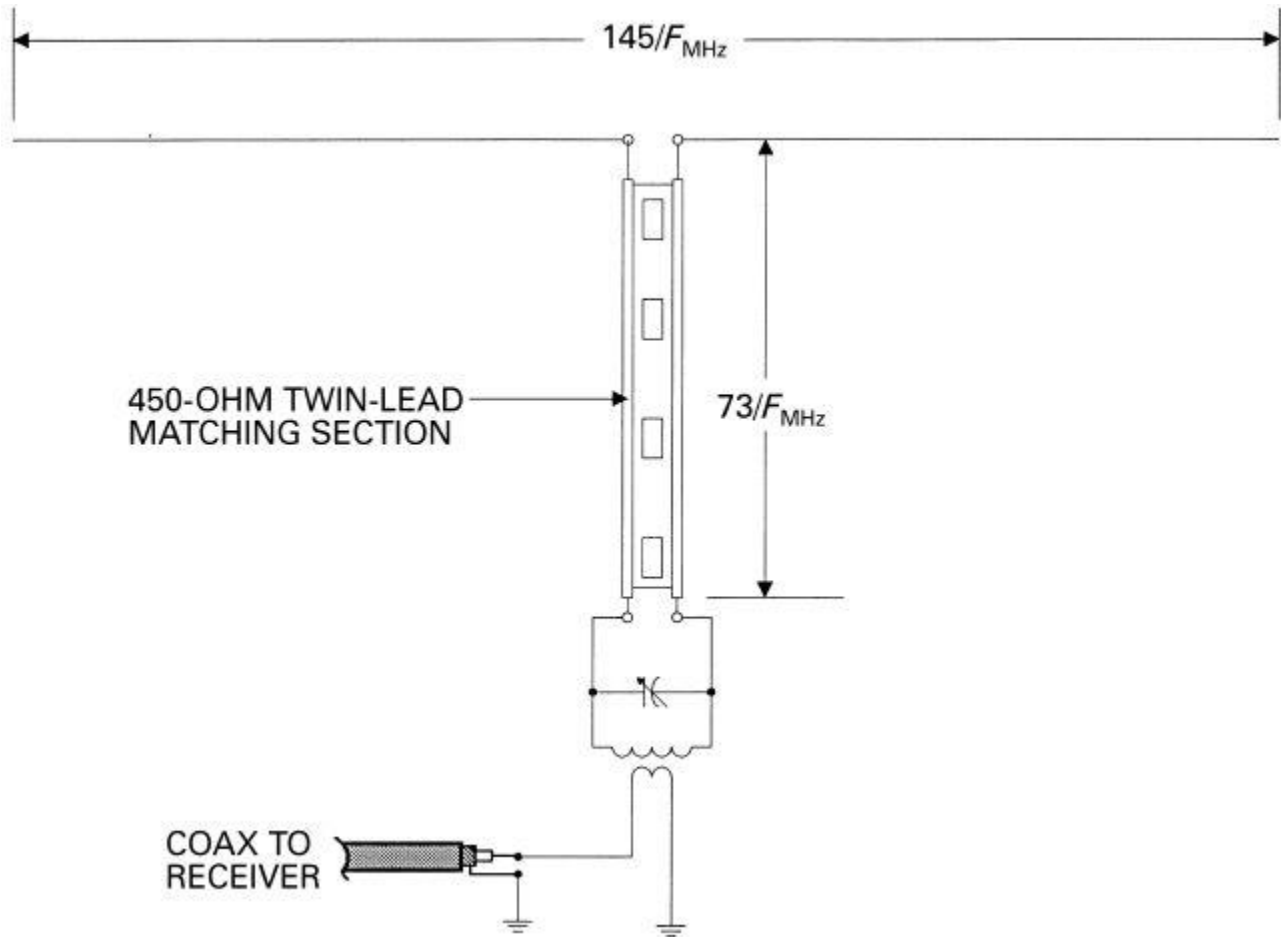

21 - G5RV Antenna

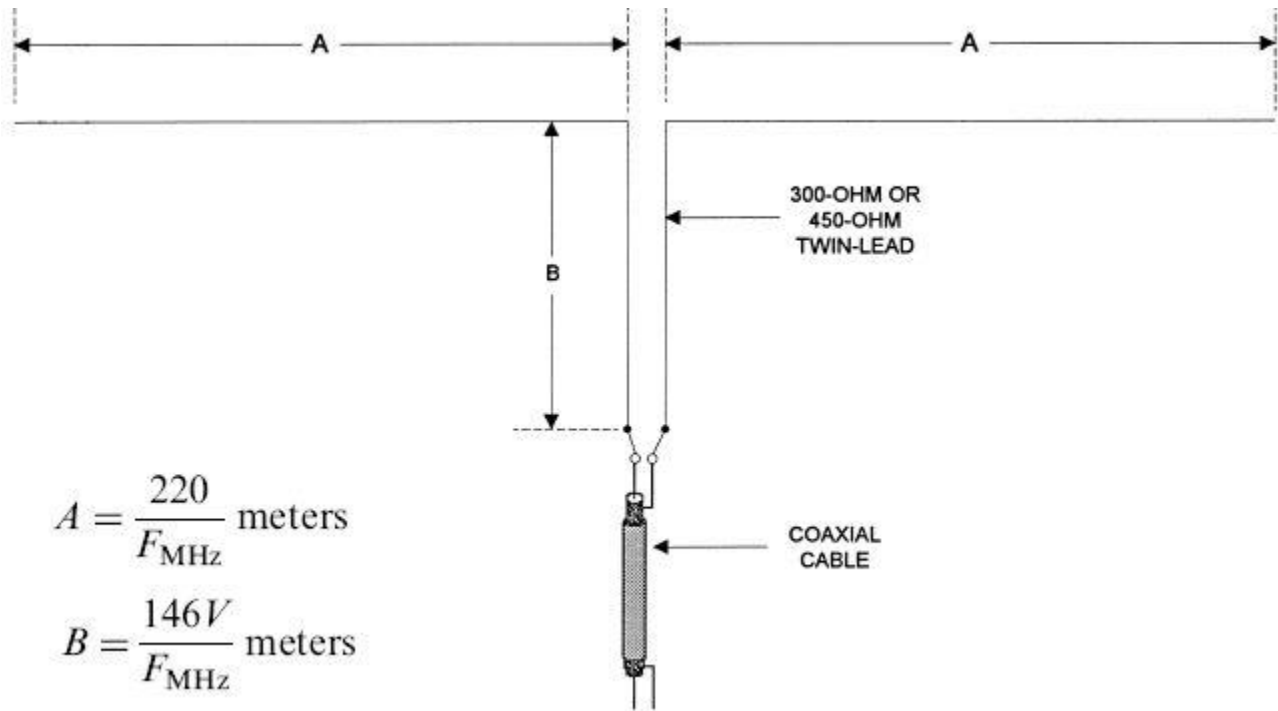

22 - Wideband Dipole Antenna

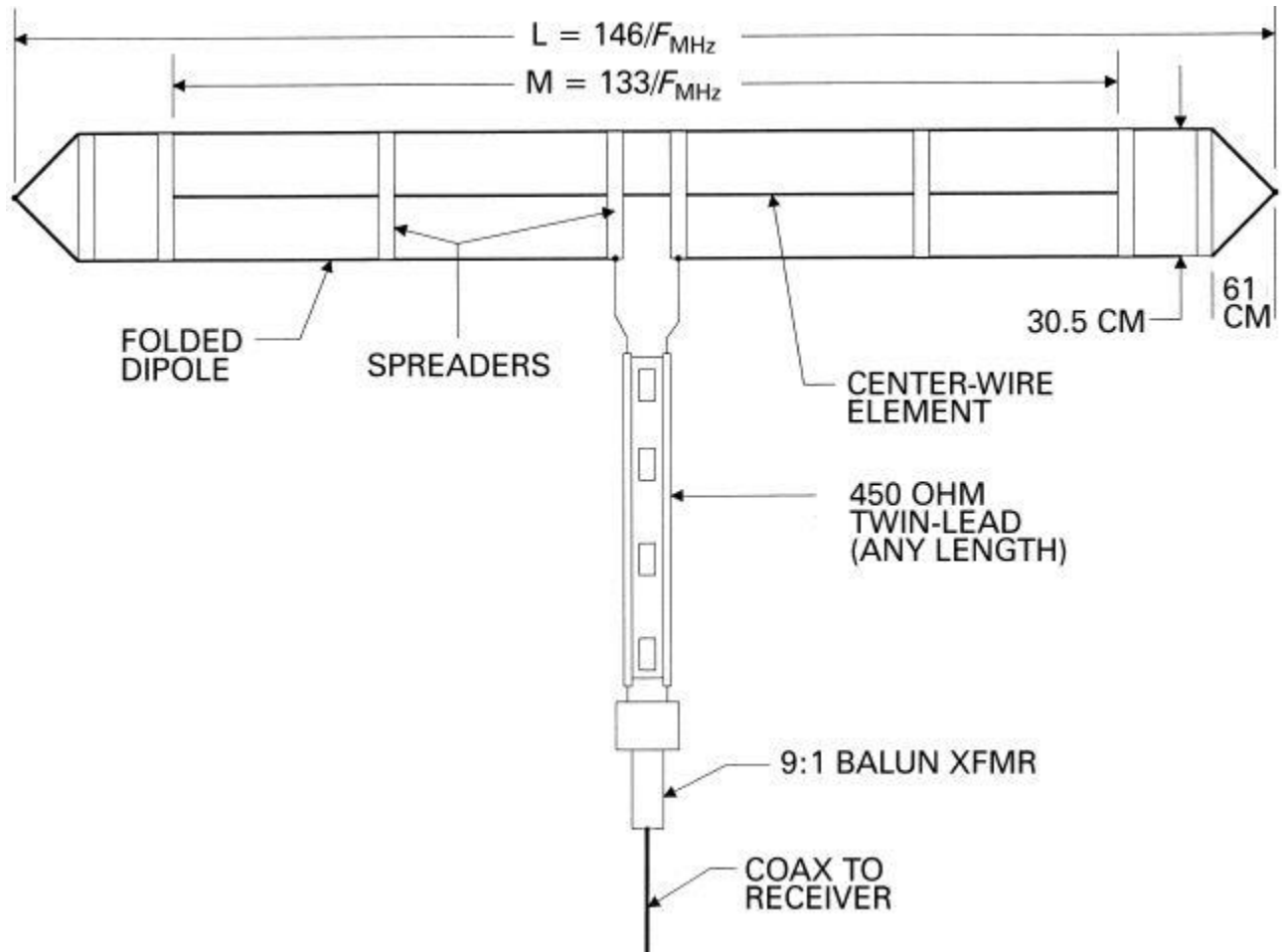

23 - Wideband Dipole for Receiving

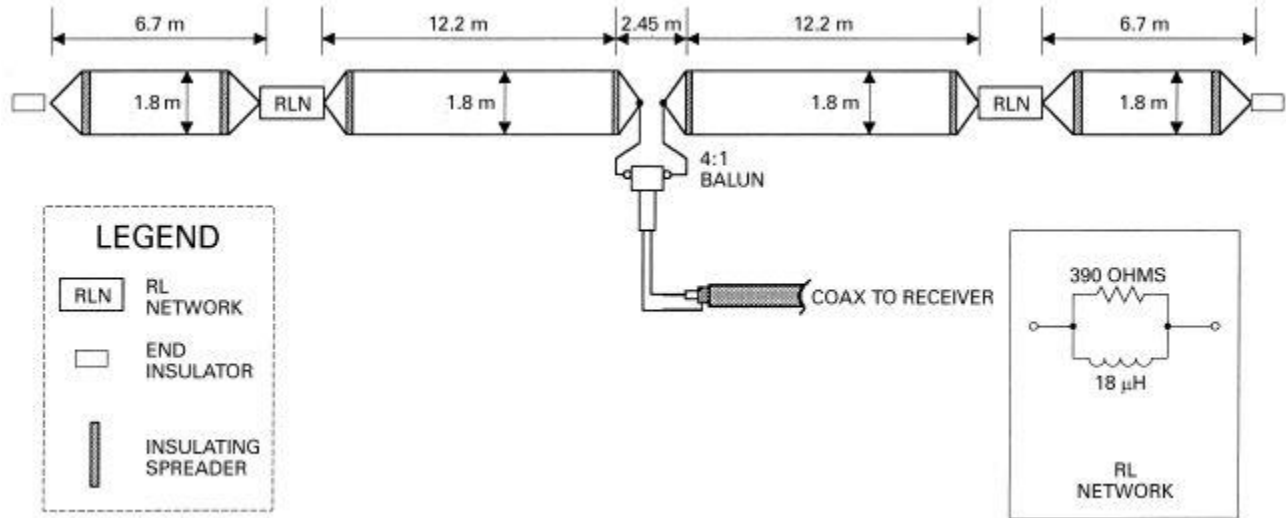

24 - Tilted Folded Dipole Antenna

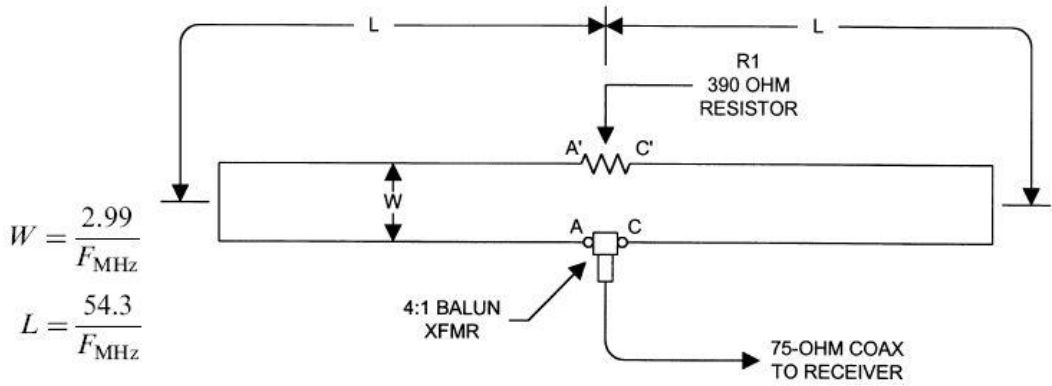

25 - Right Angle Marconi Antenna

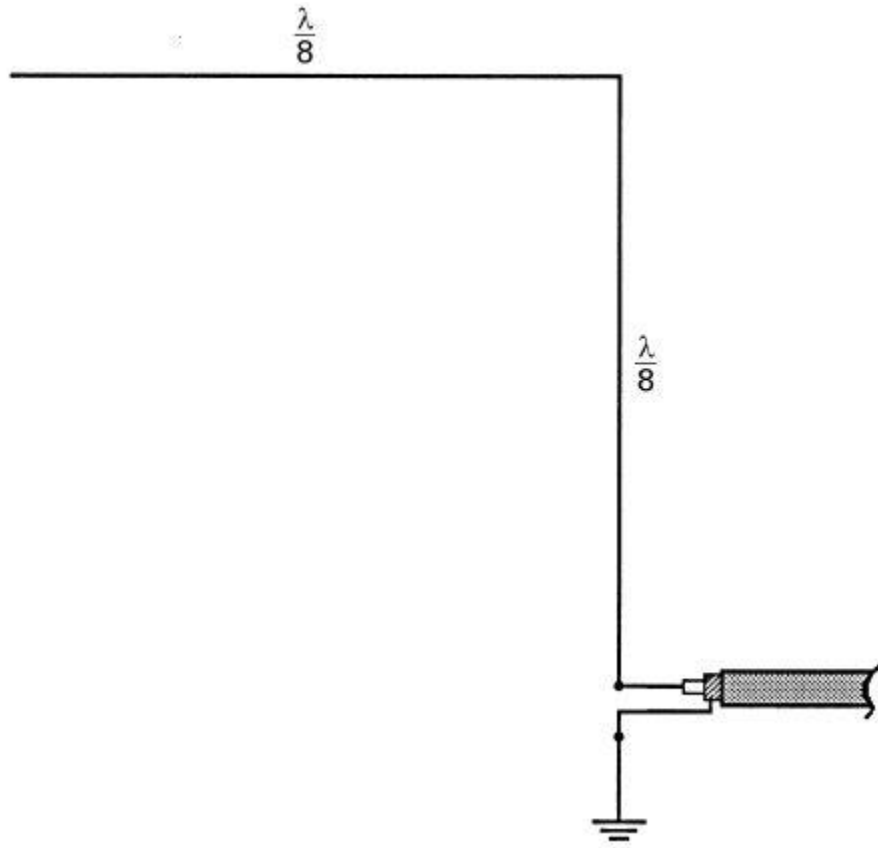

26 - Linearly Loaded Tee Antenna

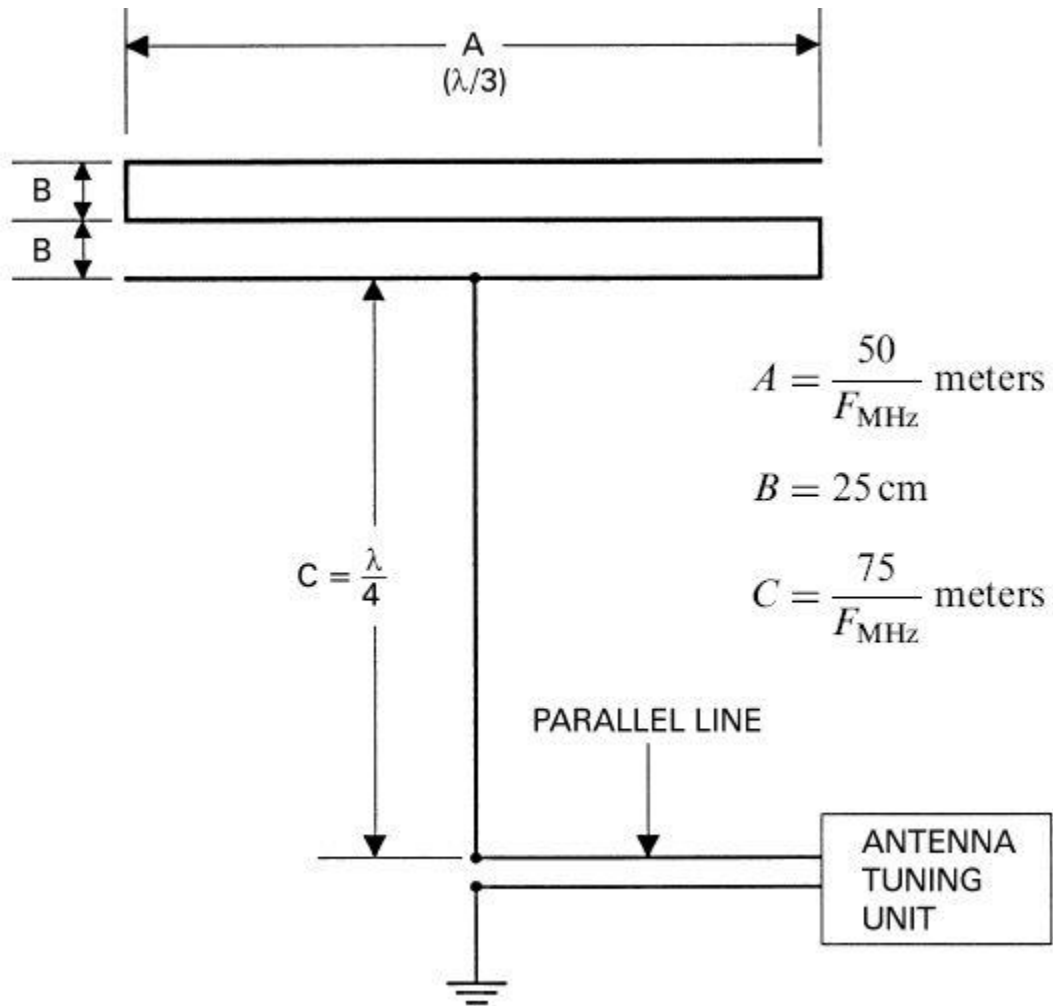

27 - Reduced Size Dipole Antenna

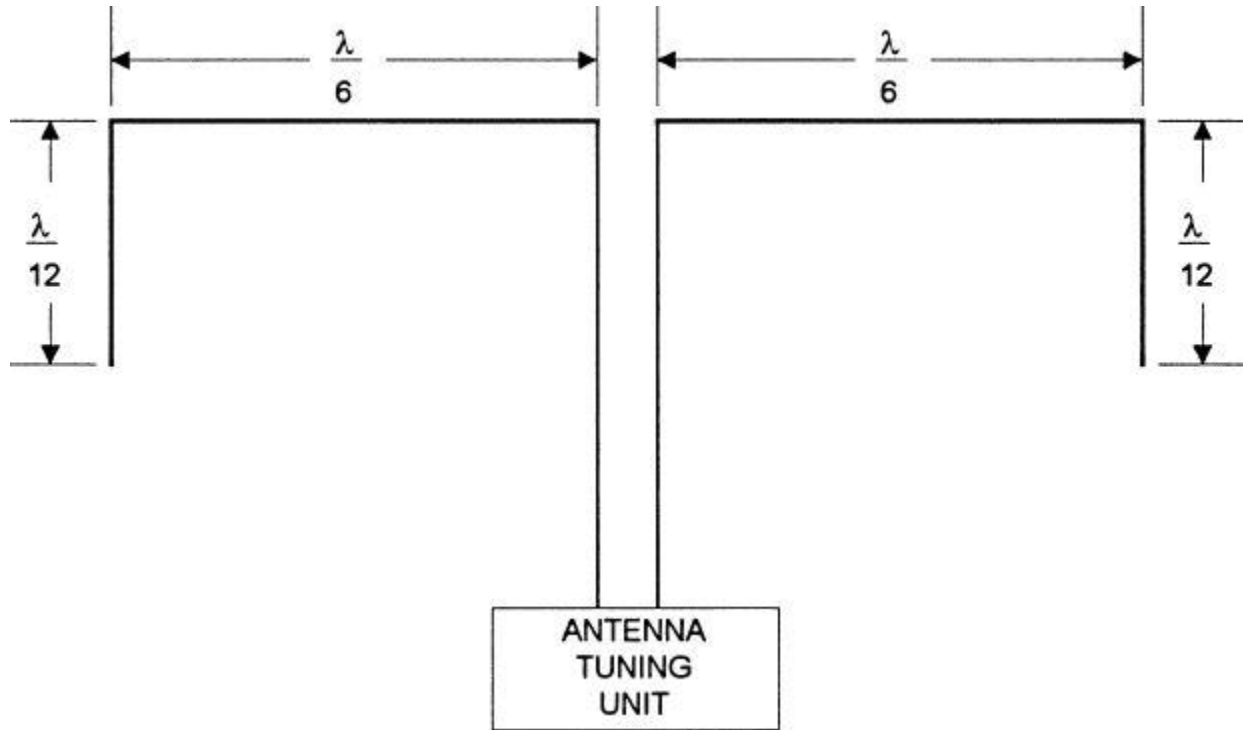

28 - Doublet Dipole Antenna

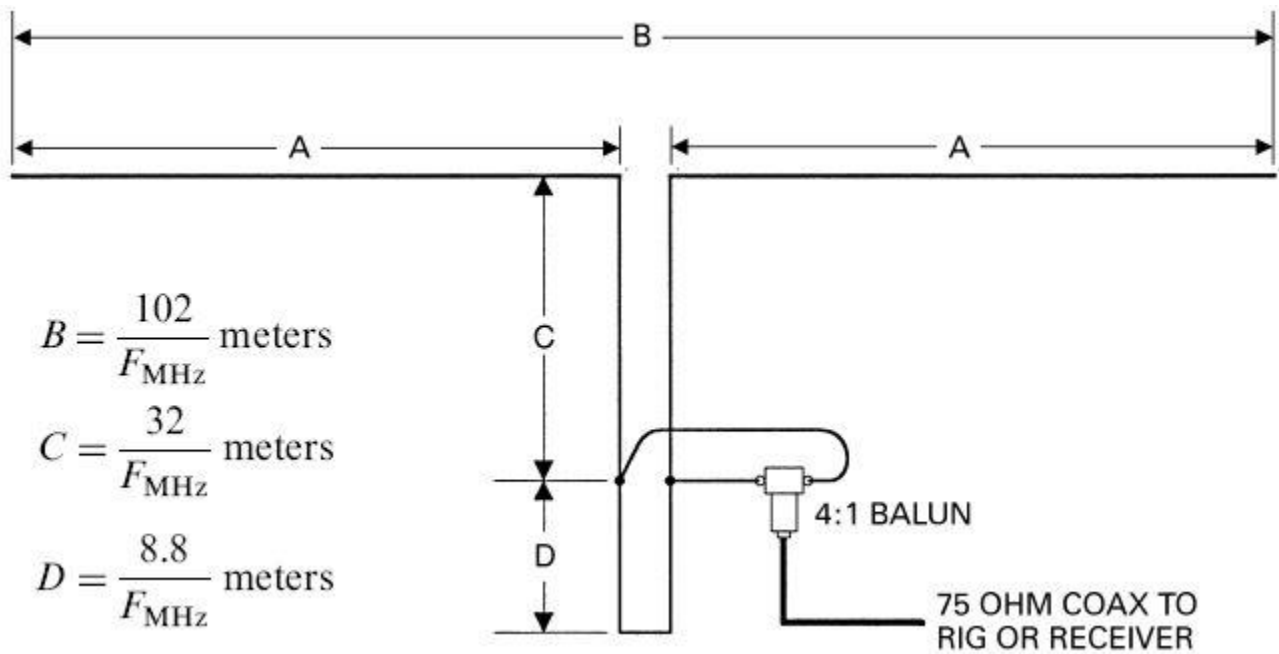

29 - Delta Loop Antenna

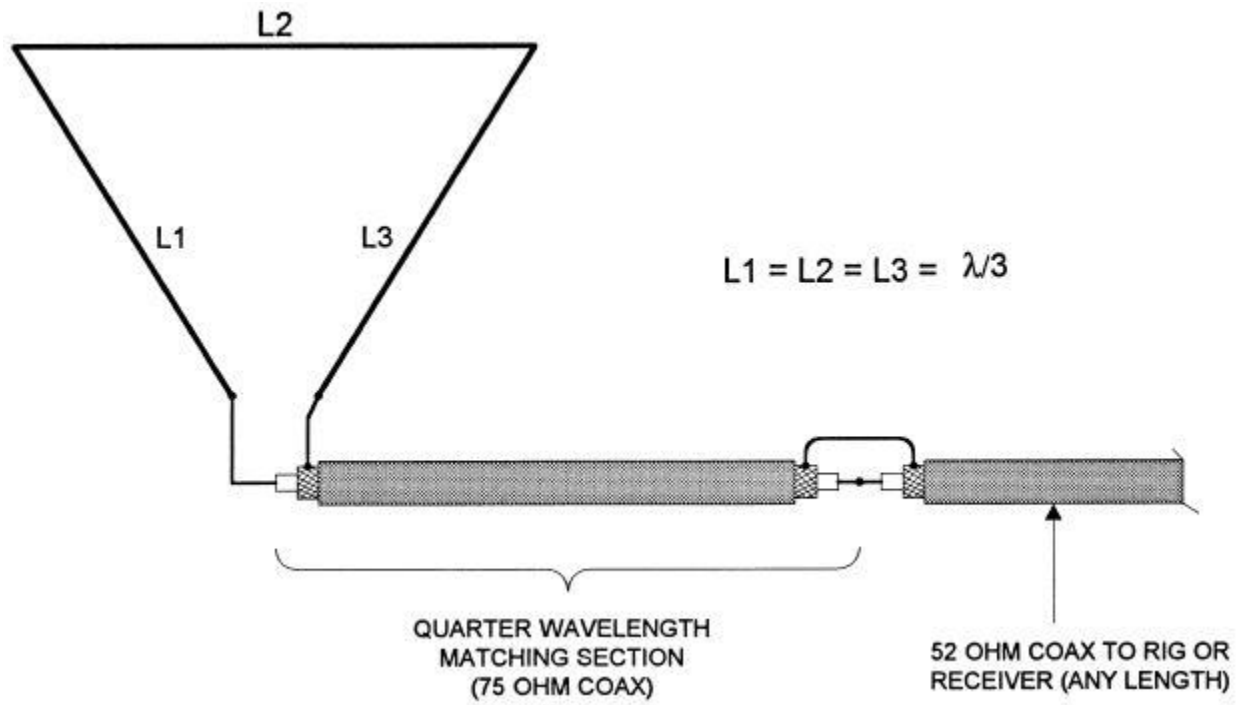

30 - Half Delta Loop Antenna

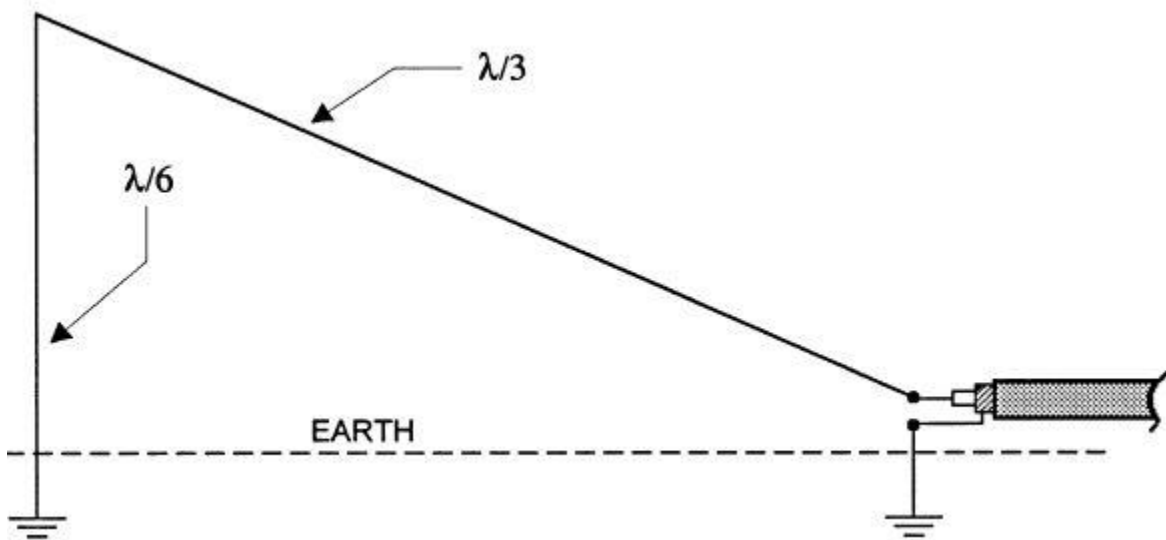

31 - Collinear Franklin Antenna

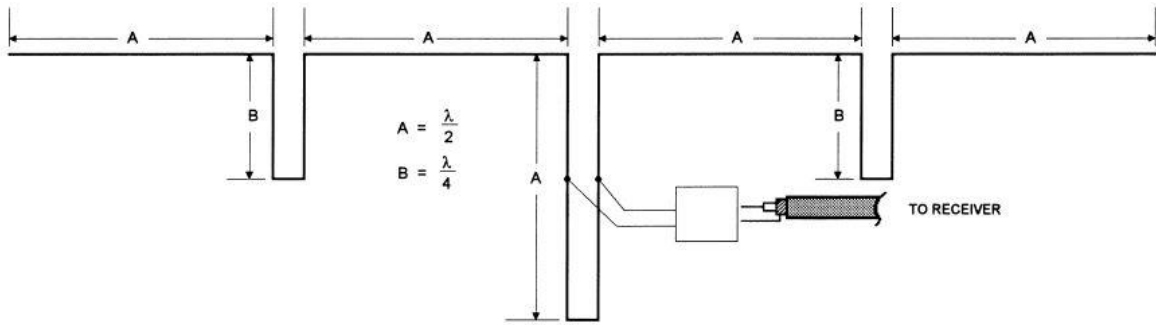

32 - Four Element Broadside Antenna

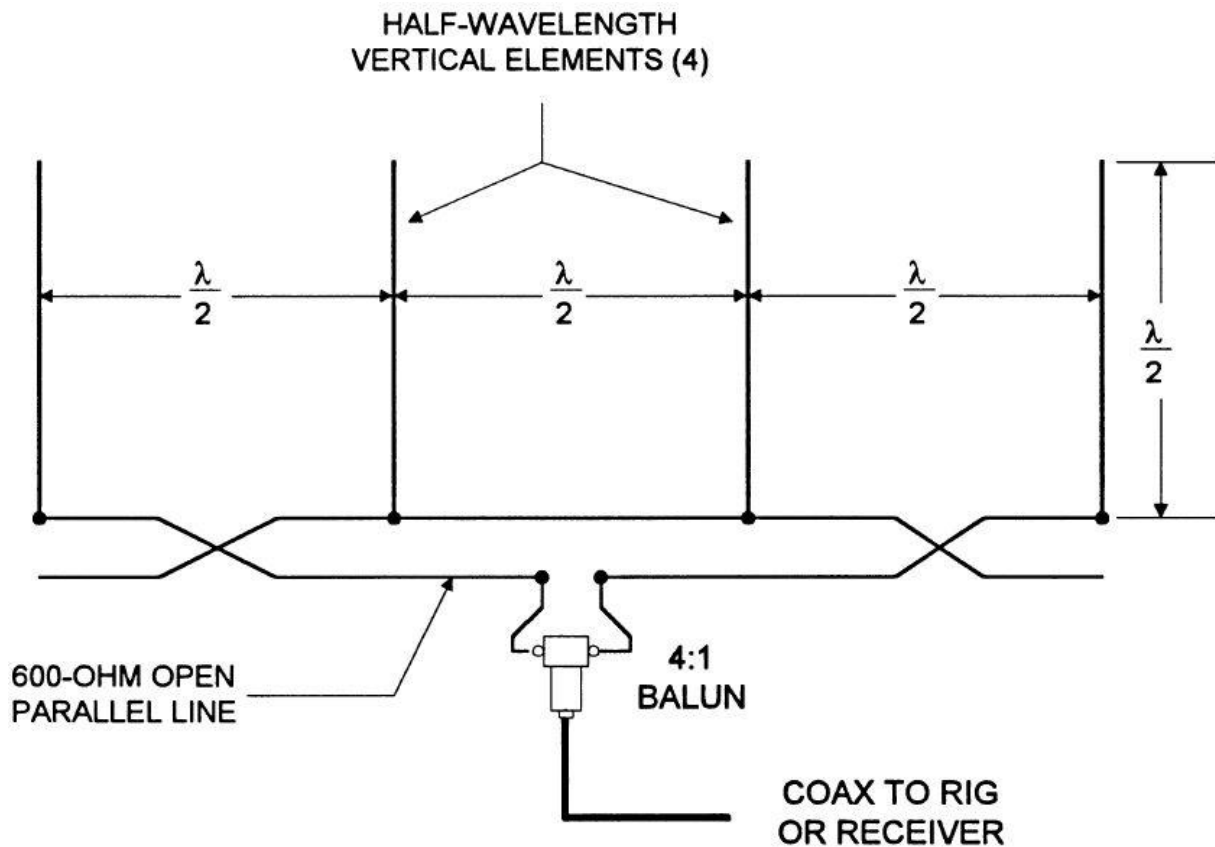

33 - The Lazy-H Array Antenna

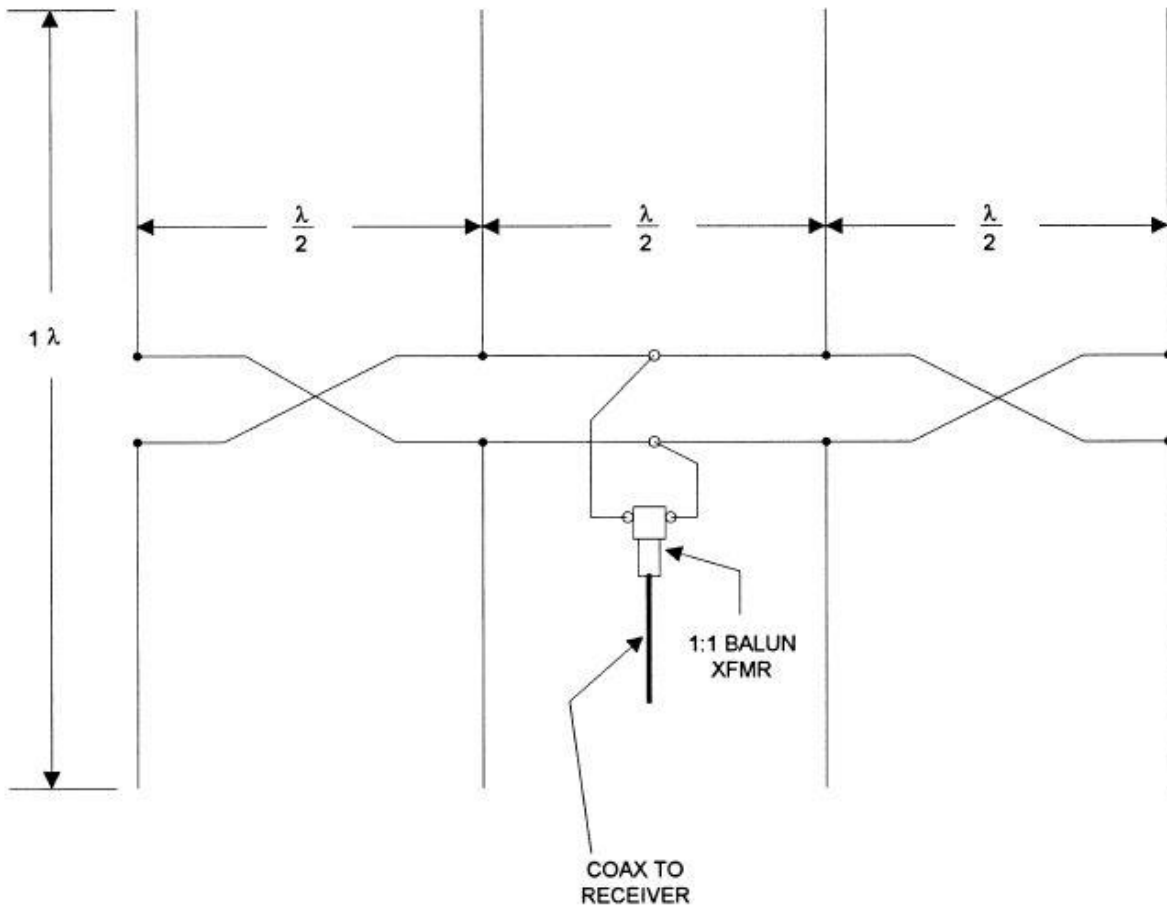

34 - Sterba Curtain Array Antenna

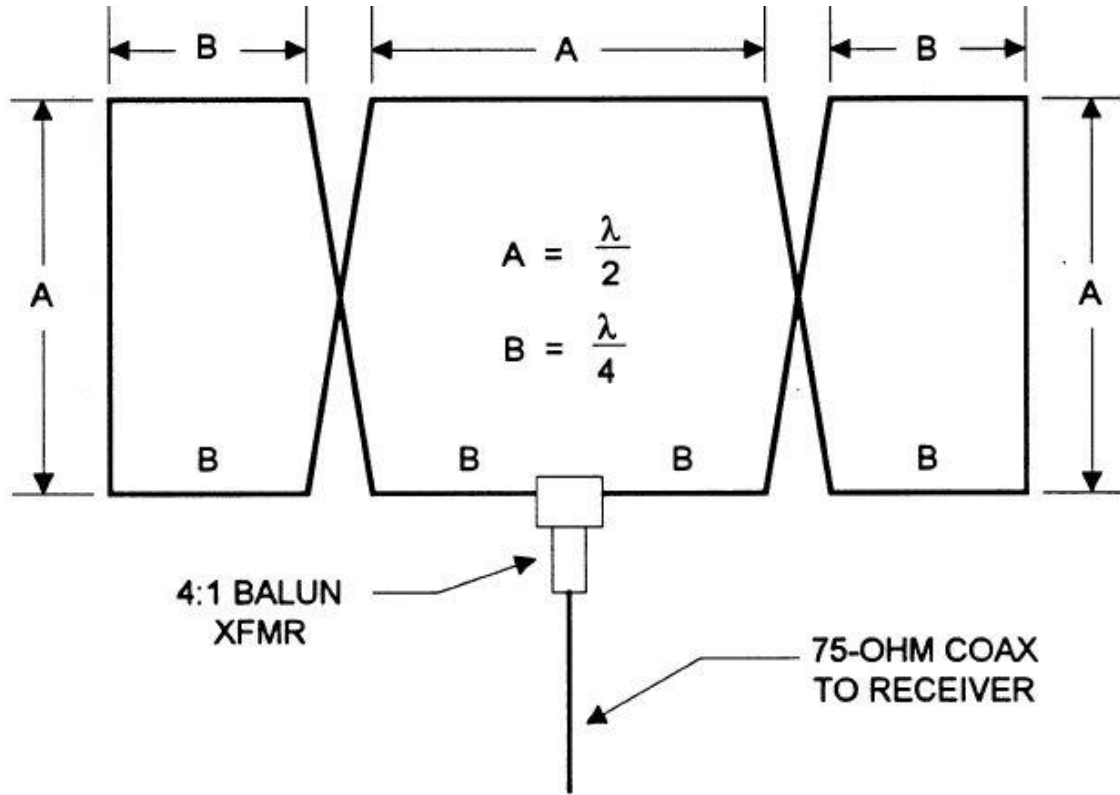

35 - T-L DX Antenna

- $L1 = \frac{53.2}{f_{\text{MHz}}}$ meters
- $L2 = \frac{39.8}{f_{\text{MHz}}}$ meters
- $L3 = \frac{66.6}{f_{\text{MHz}}}$ meters
- $L4 = \frac{21.3}{f_{\text{MHz}}}$ meters
- $L5 = \frac{108.4}{f_{\text{MHz}}}$ meters
- $L6 = \frac{94.2}{f_{\text{MHz}}}$ meters
- $L7 = \frac{136.8}{f_{\text{MHz}}}$ meters

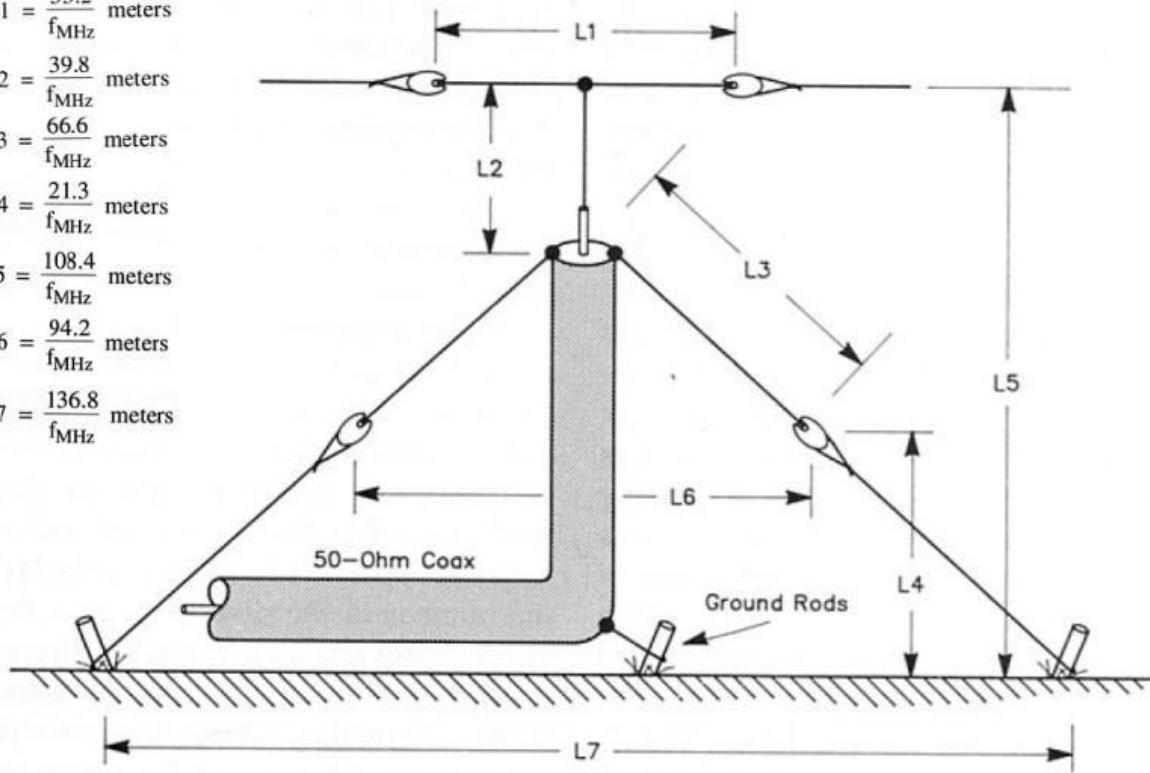

36 - 1.9 MHz Full-wave Loop Antenna

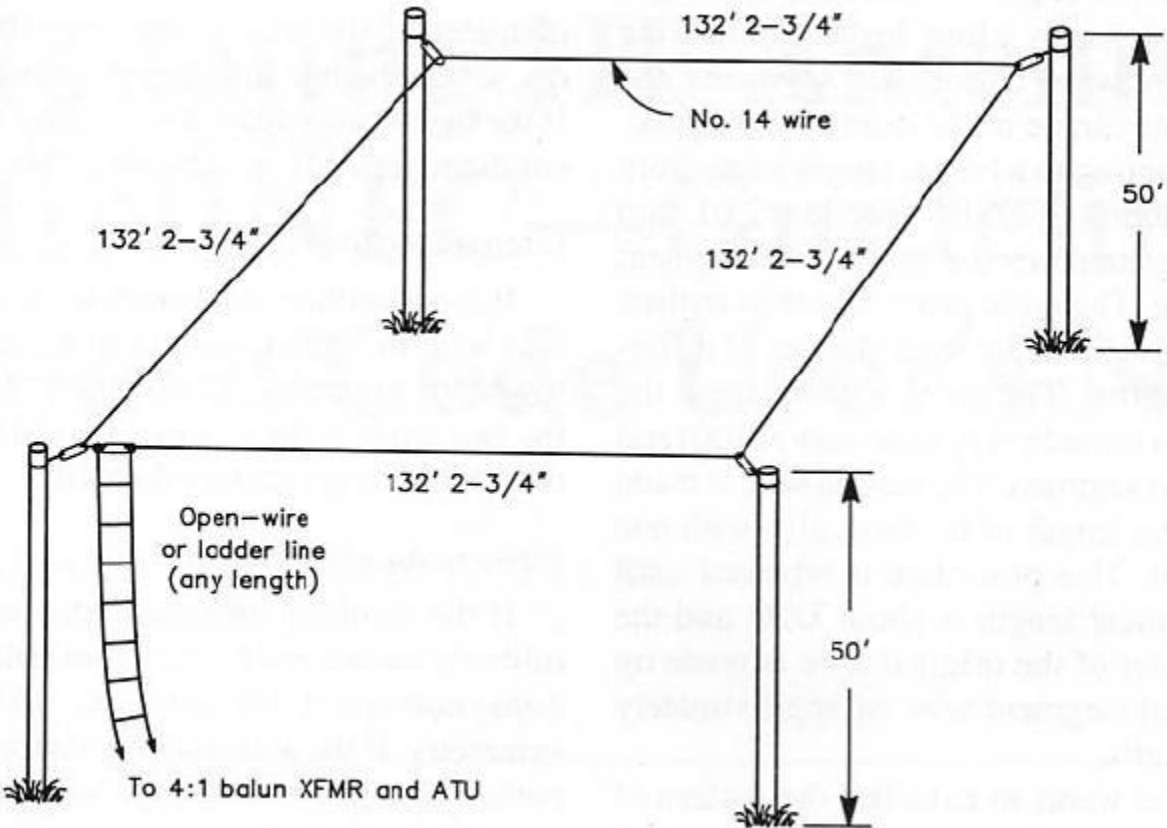

37 - Multi-Band Portable Antenna

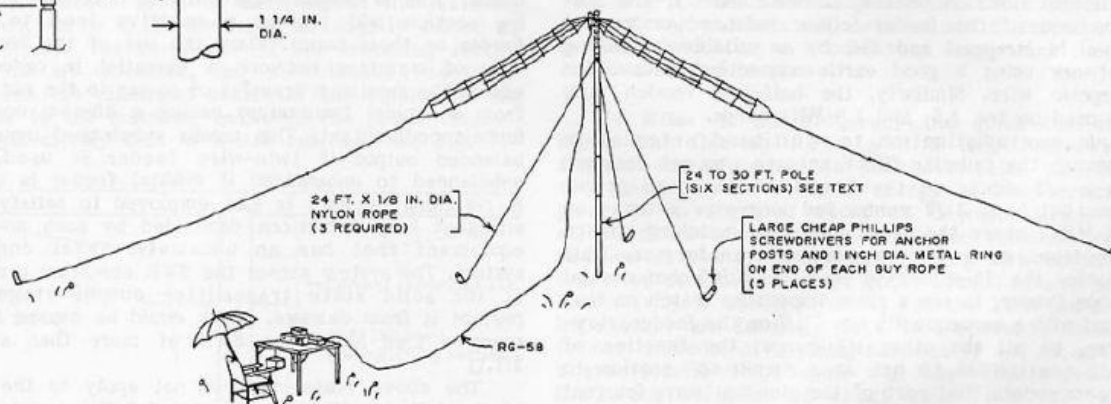
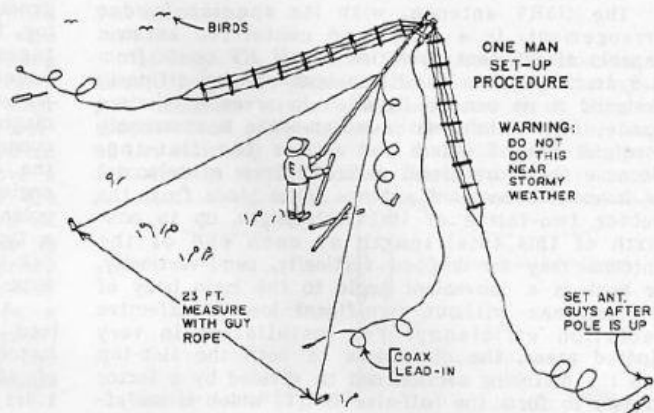
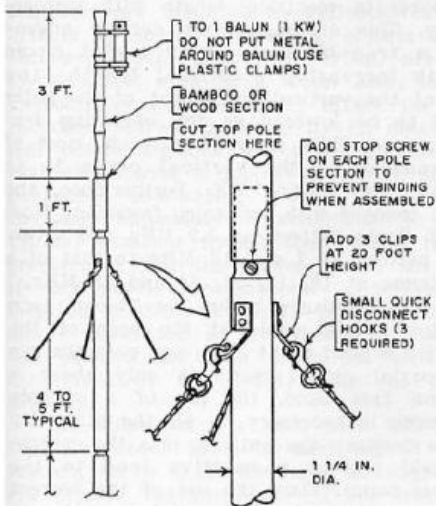
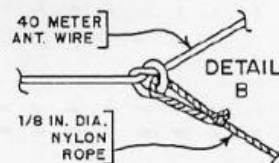
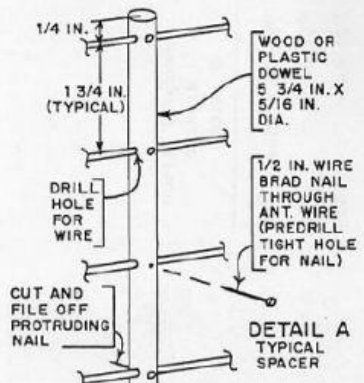
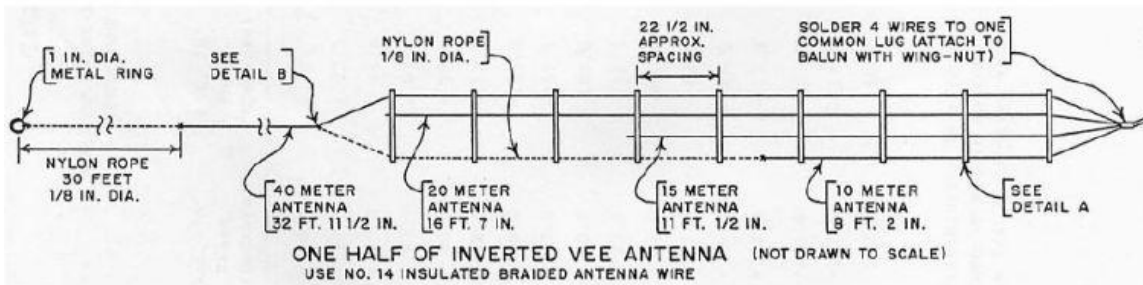

38 - Off-center-fed Full-wave Doublet Antenna

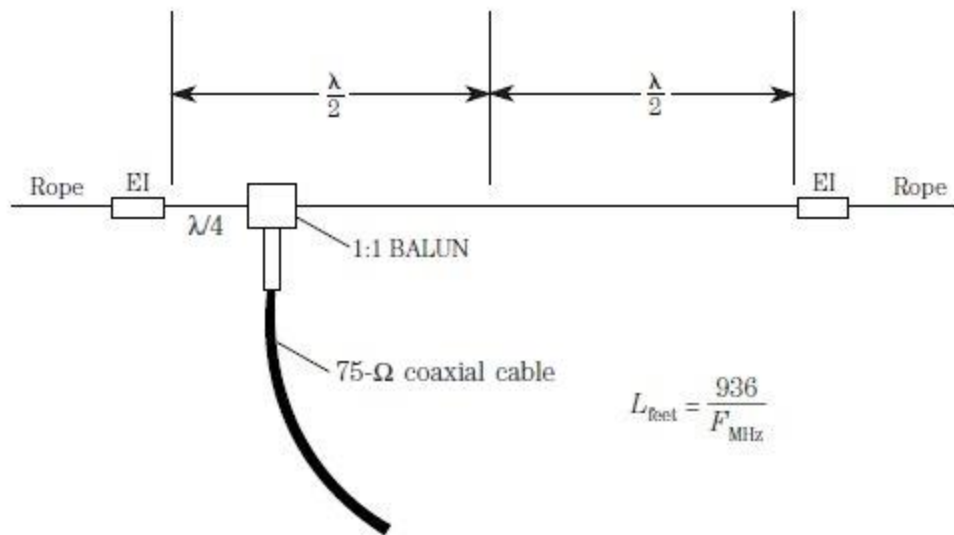

39 - Terminated Sloper Antenna

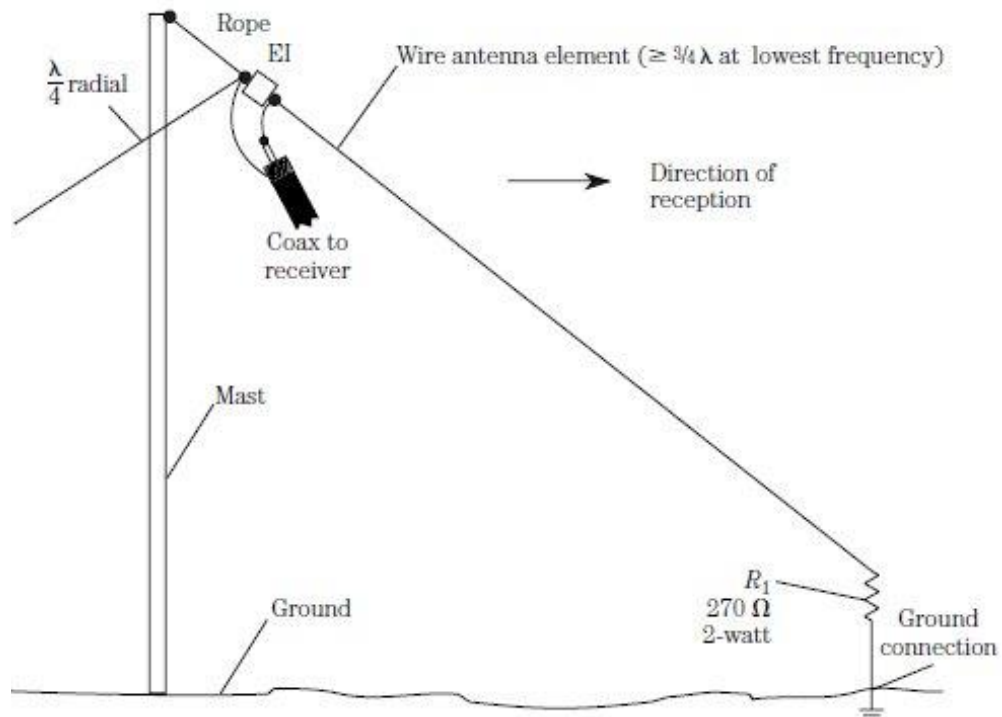

40 - Double Extended Zepp Antenna

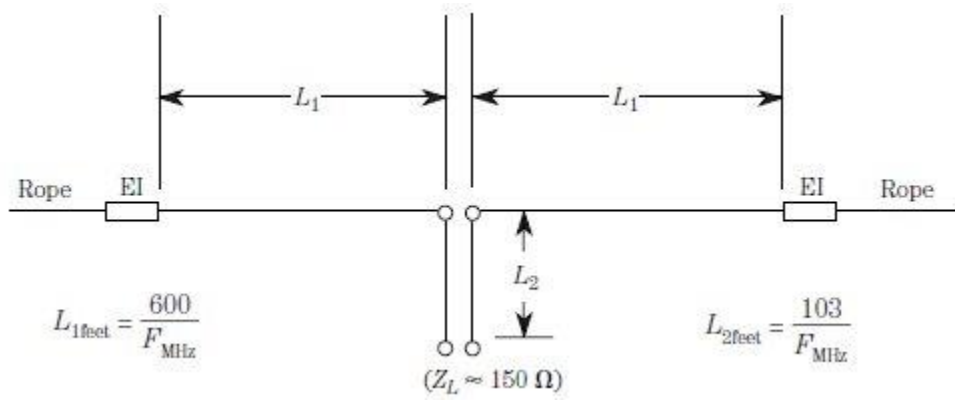

41 - TCFTFD Dipole Antenna

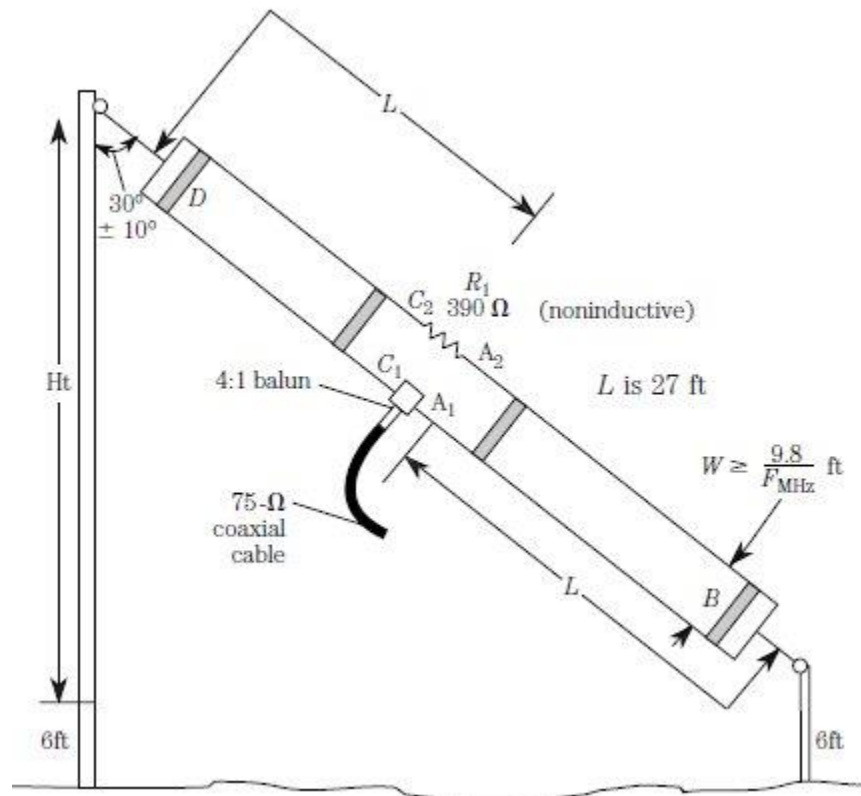

42 - Vee-Sloper Antenna

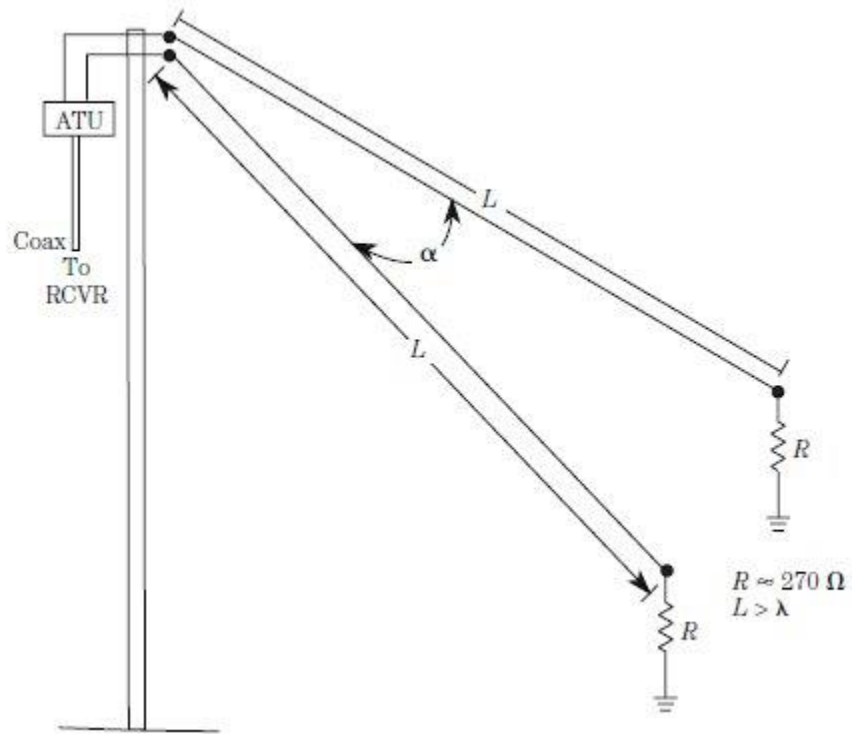

43 - Rhombic Inverted-Vee Antenna

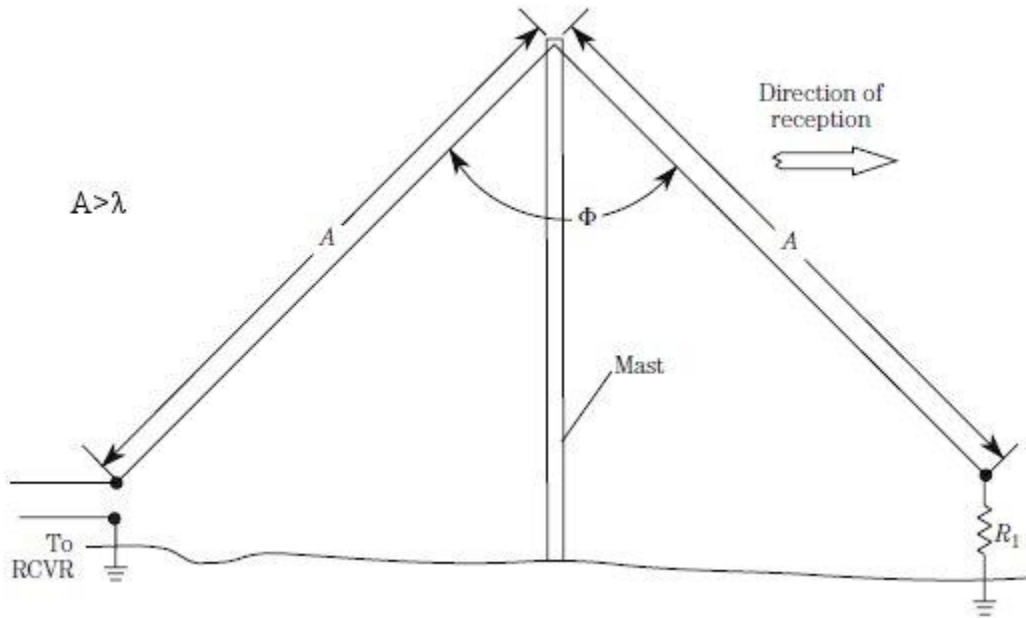

44 - Counterpoise Longwire

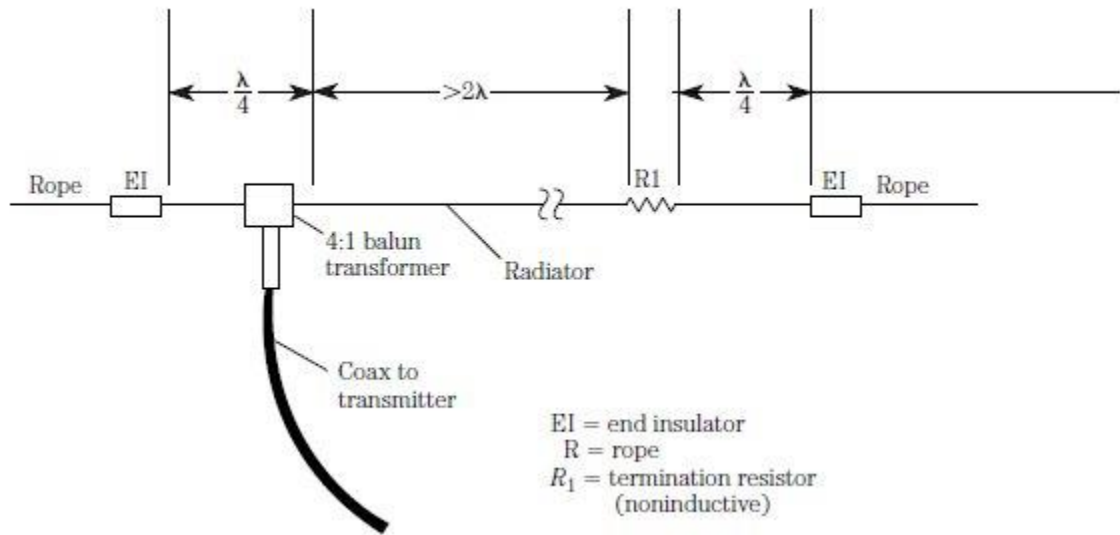

45 - Bisquare Loop Antenna

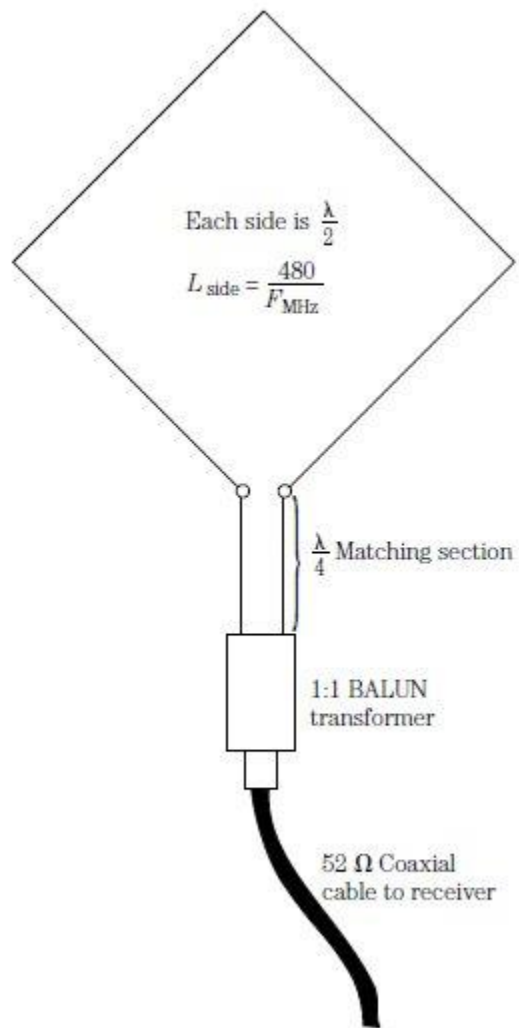

46 - Piggyback Antenna for 10m

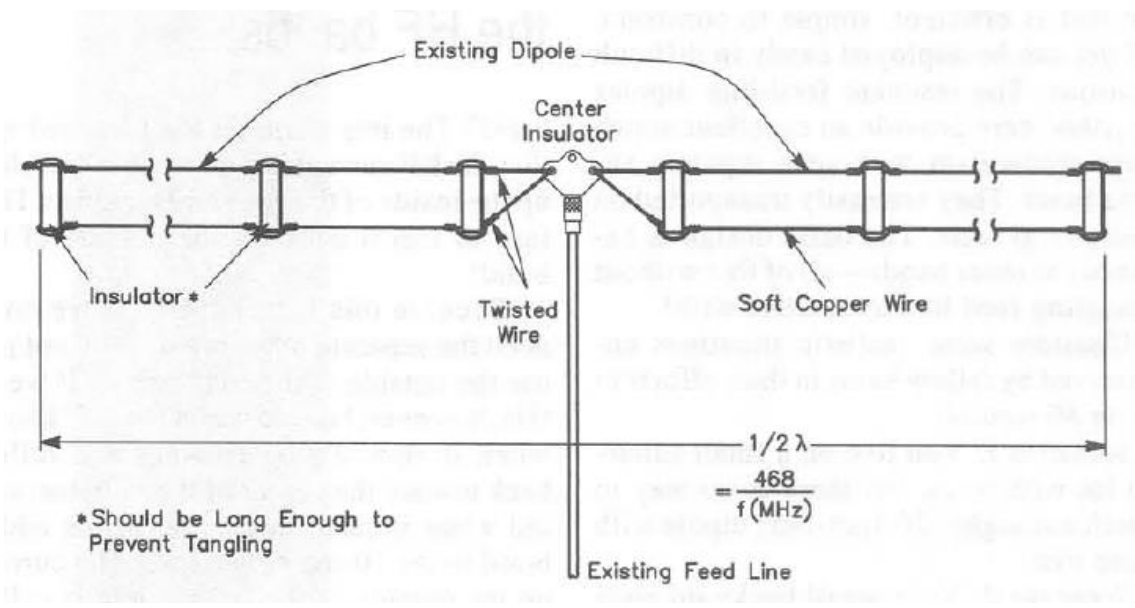

47 - Vertical Sleeve Antenna for 10m

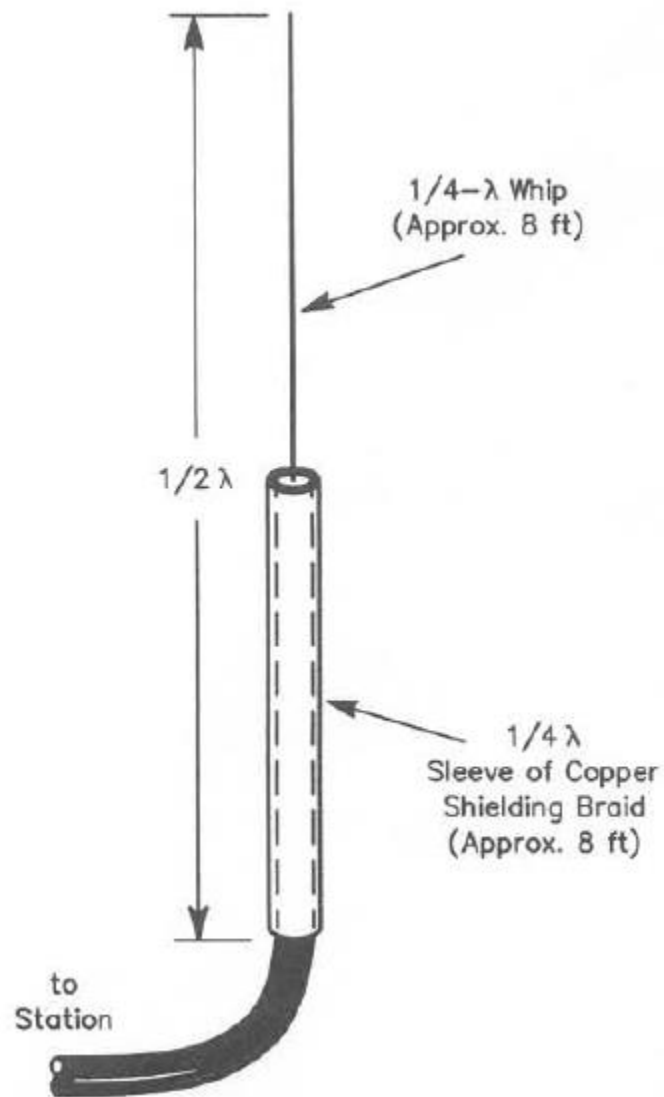

48 - Double Windom Antenna

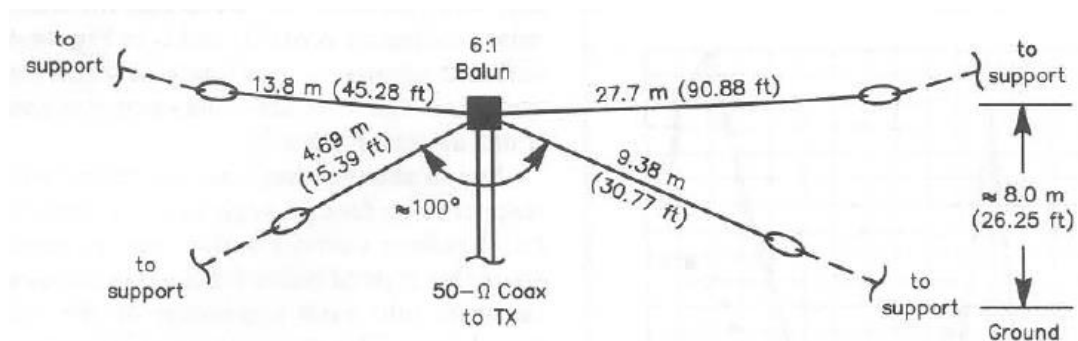

49 - Double Windom for 9 Bands

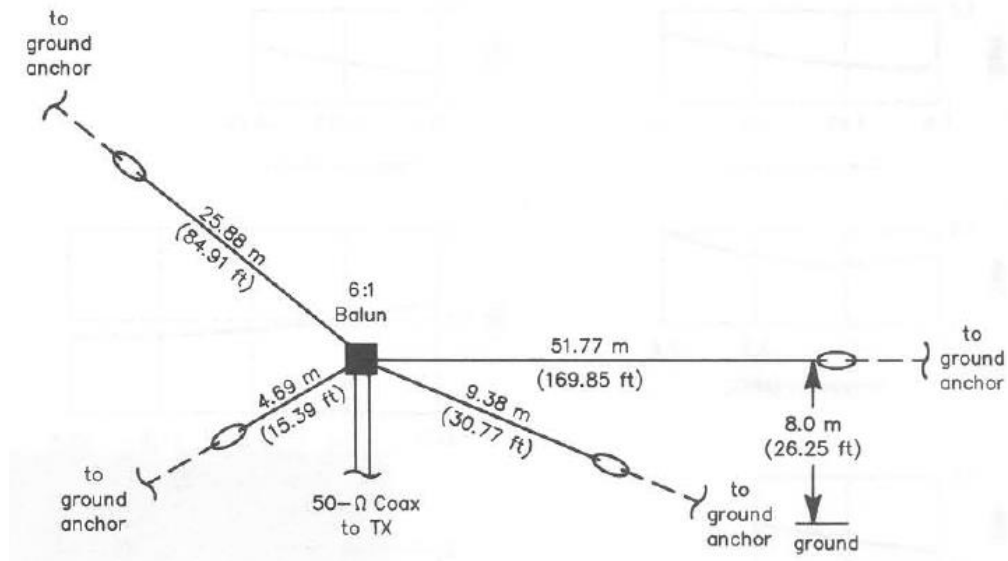

50 - Collinear Trap Antenna

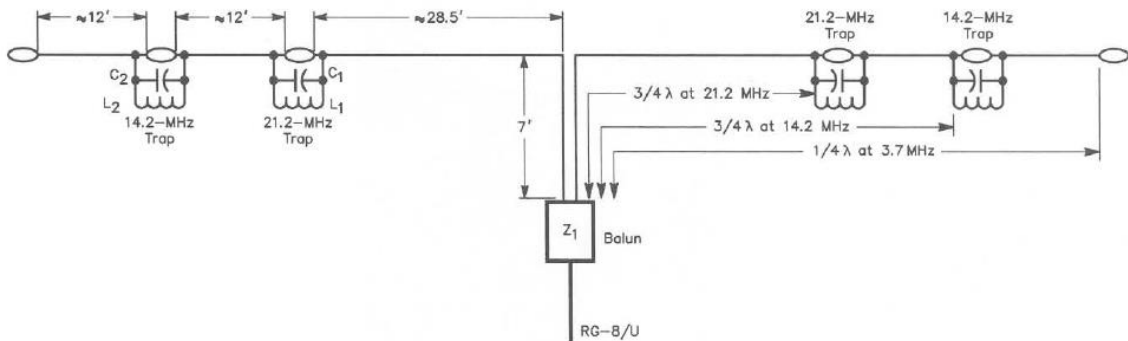

C1, C2—25-pf. 6000-volt disk ceramic. See text.
 L₁—Approx. 2 μ H—4 $\frac{3}{4}$ turns No. 18, 2 $\frac{1}{4}$ -inches diam., $\frac{5}{8}$ inch long, or 5 turns No. 18, 2-inch diam., 16 tpi. See text.

L₂—Approx. 5 μ H.—8 turns No. 18, 2 $\frac{1}{4}$ -inch dia., $\frac{5}{8}$ inch long, or 9 turns No. 18, 2-inch diam., 16 tpi. See text.
 Z₁—1 to 1 balun.

51 - Short Dipole Antenna for 40m - 80m - 160m

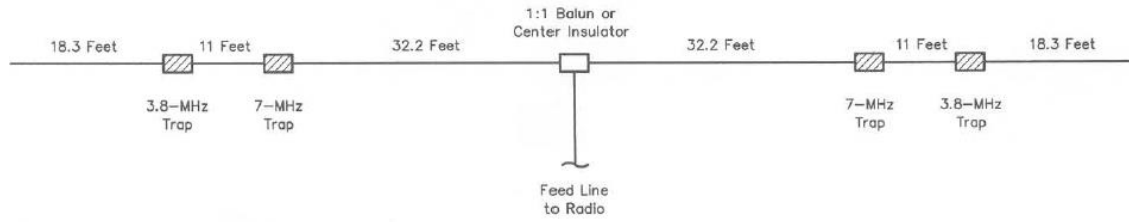

52 - Center Fed-Zepp Antenna for 80m - 40m

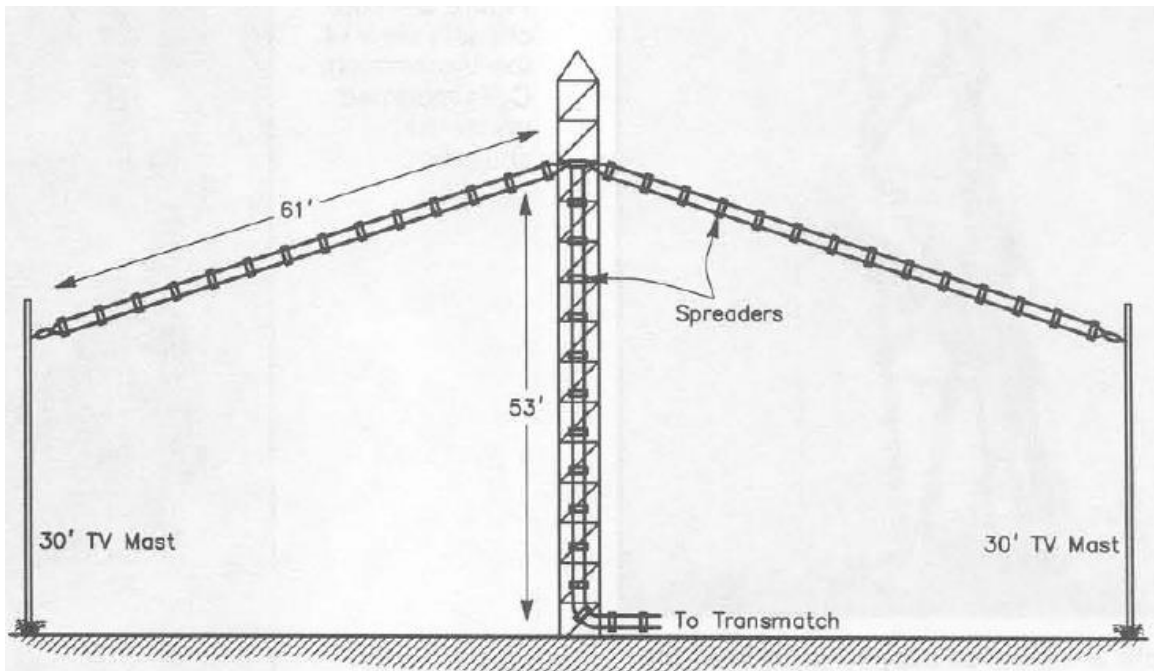

53 - All-Bands Antenna

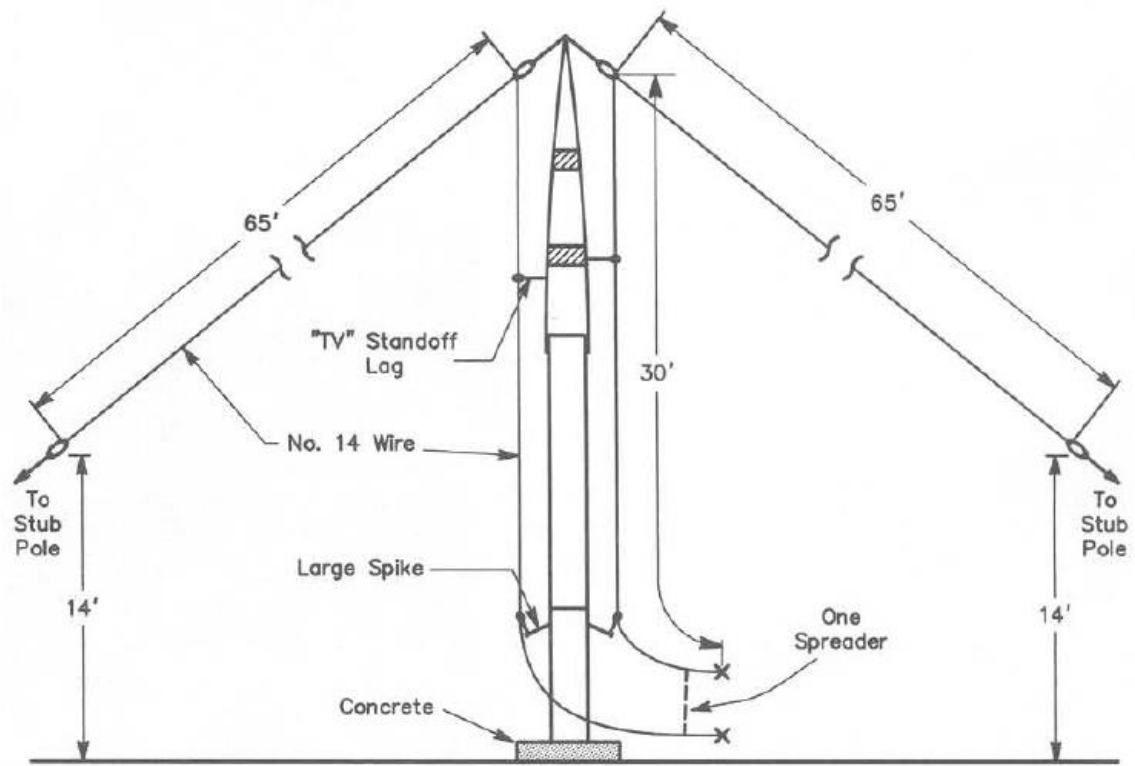

54 - All-Bands Dipole Antenna

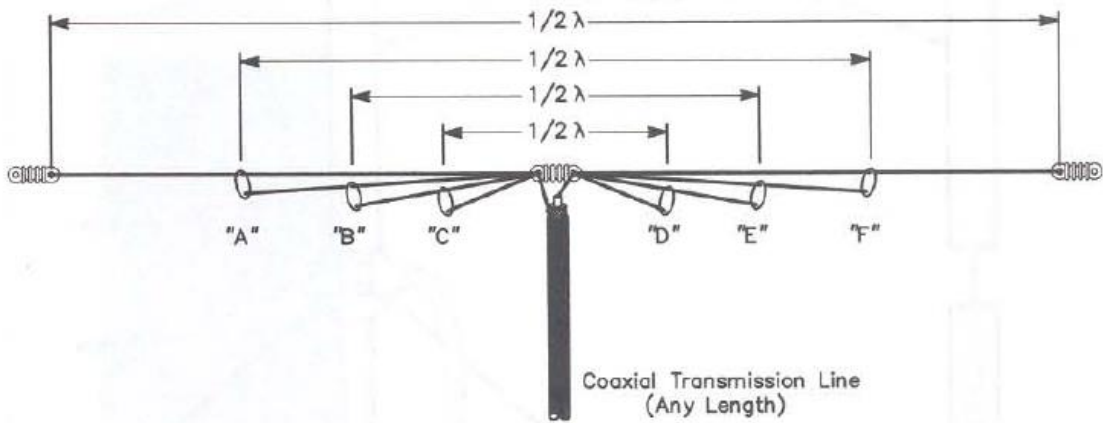

55 - Multiband Z Antenna

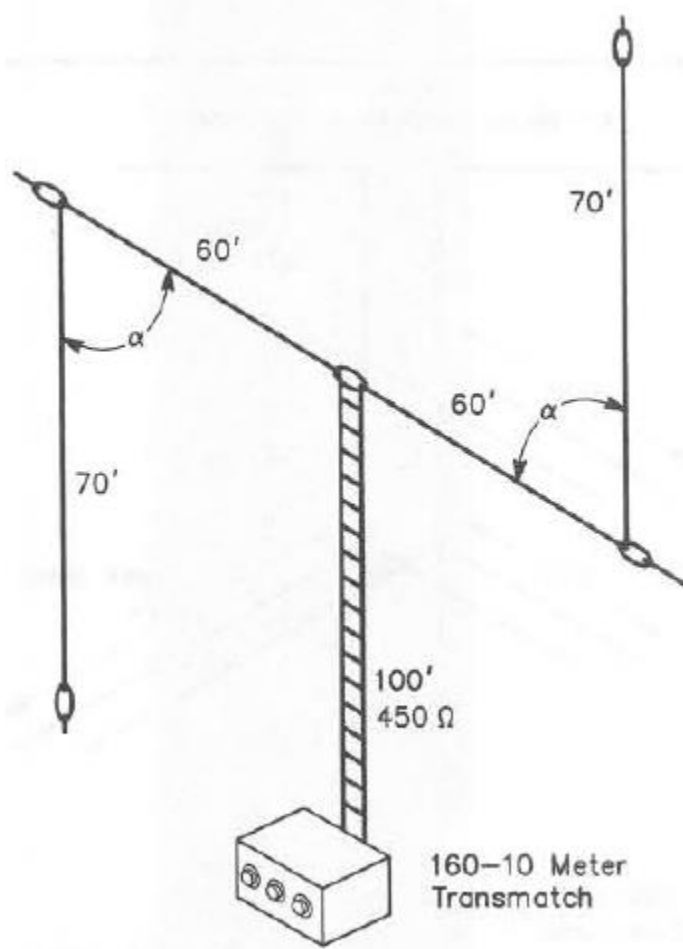

56 - Multiband Dipole Antenna

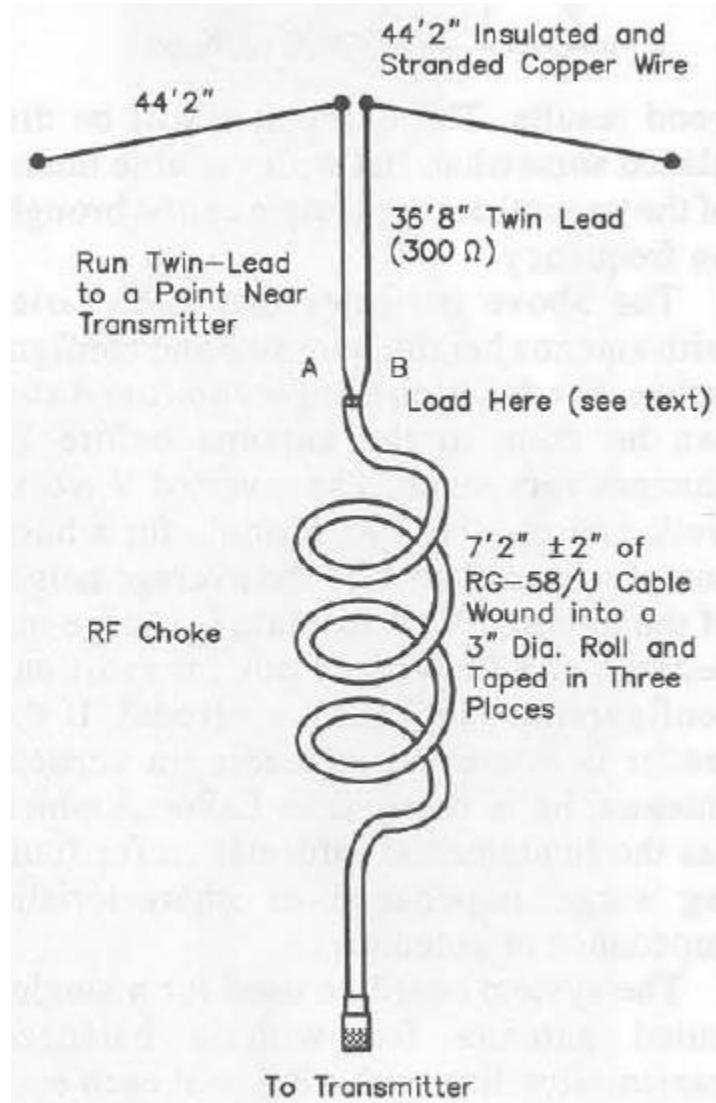

57 - Five-Bands No-Tuner Antenna

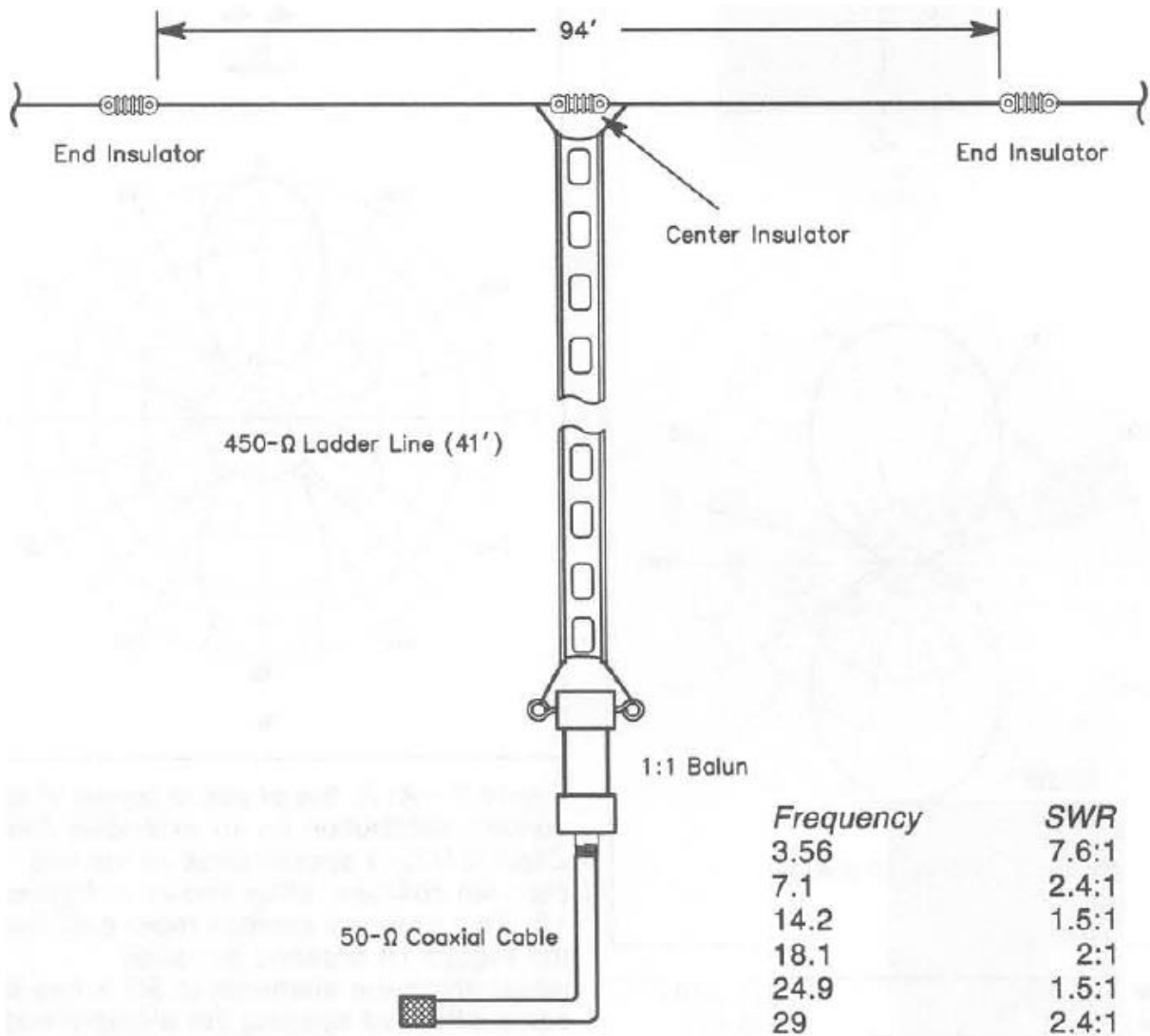

58 - Dualband Full-wave Loop Antenna for 80m-40m

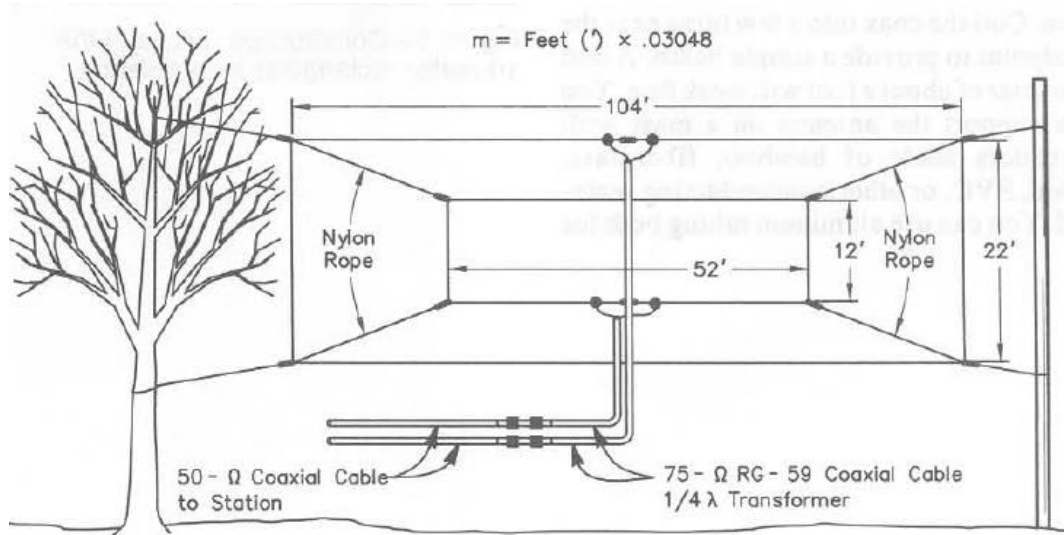

59 - Loop Antenna for 10m

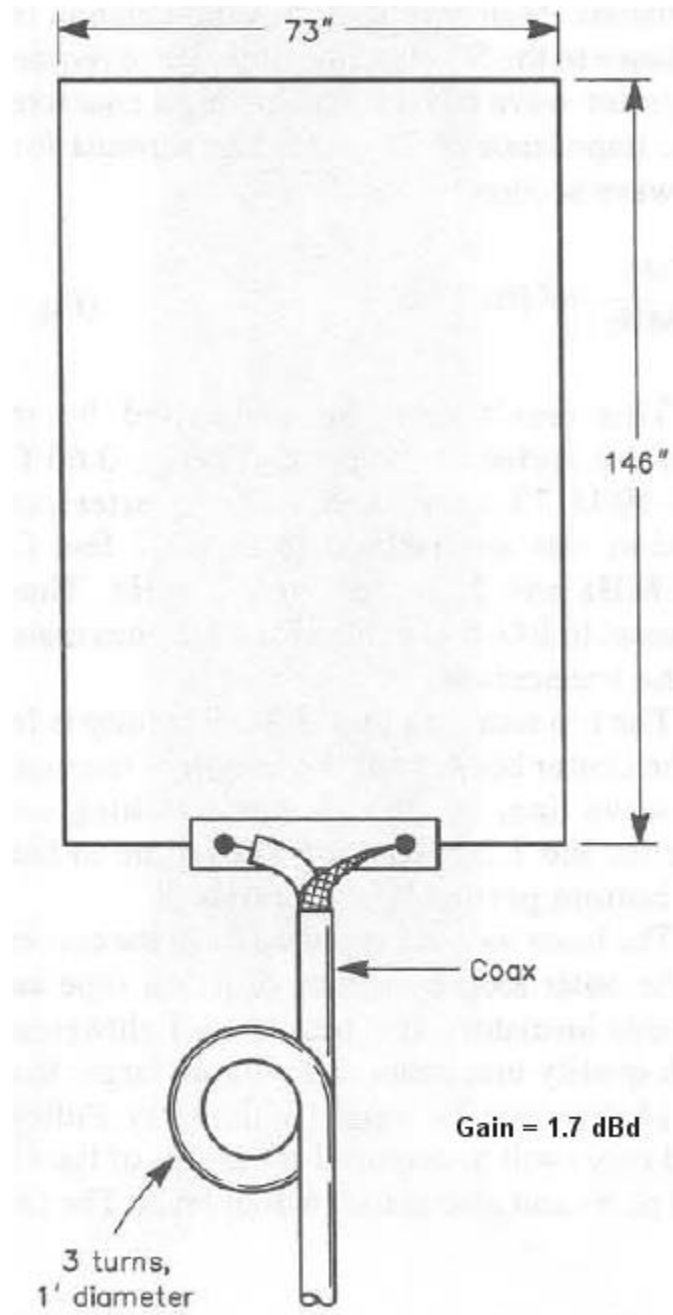

60 - Lazy Quad Antenna for 10m

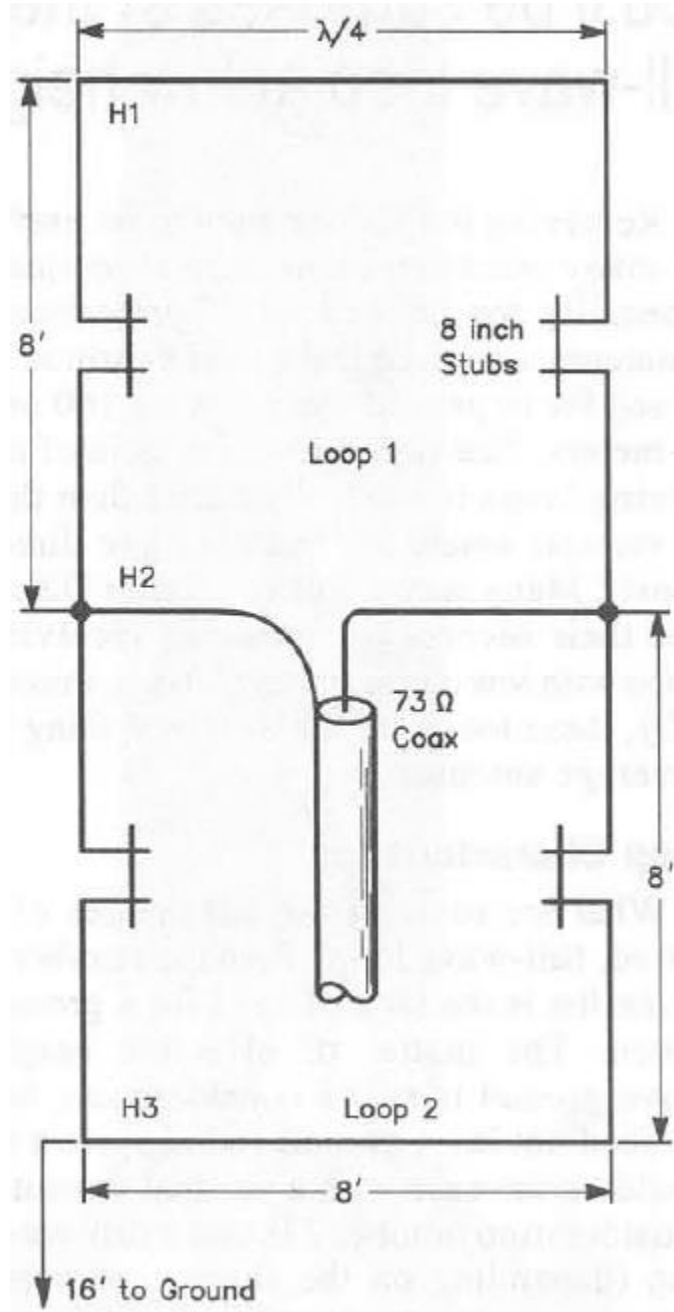

61 - Tri-band Delta Loop Antenna for 80m - 40m - 30m

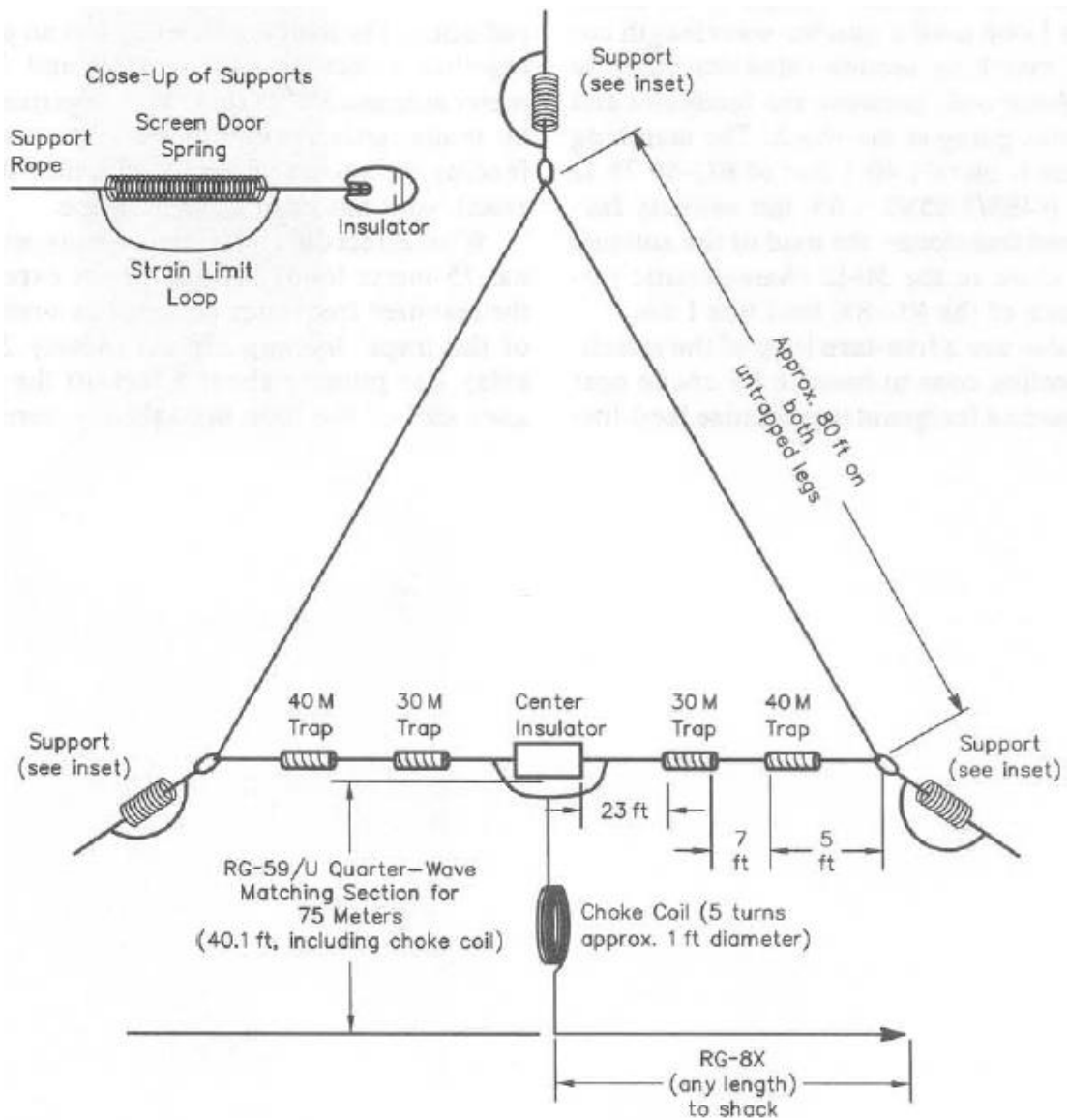

62 - Dual-band Loop Antenna for 30m - 40m

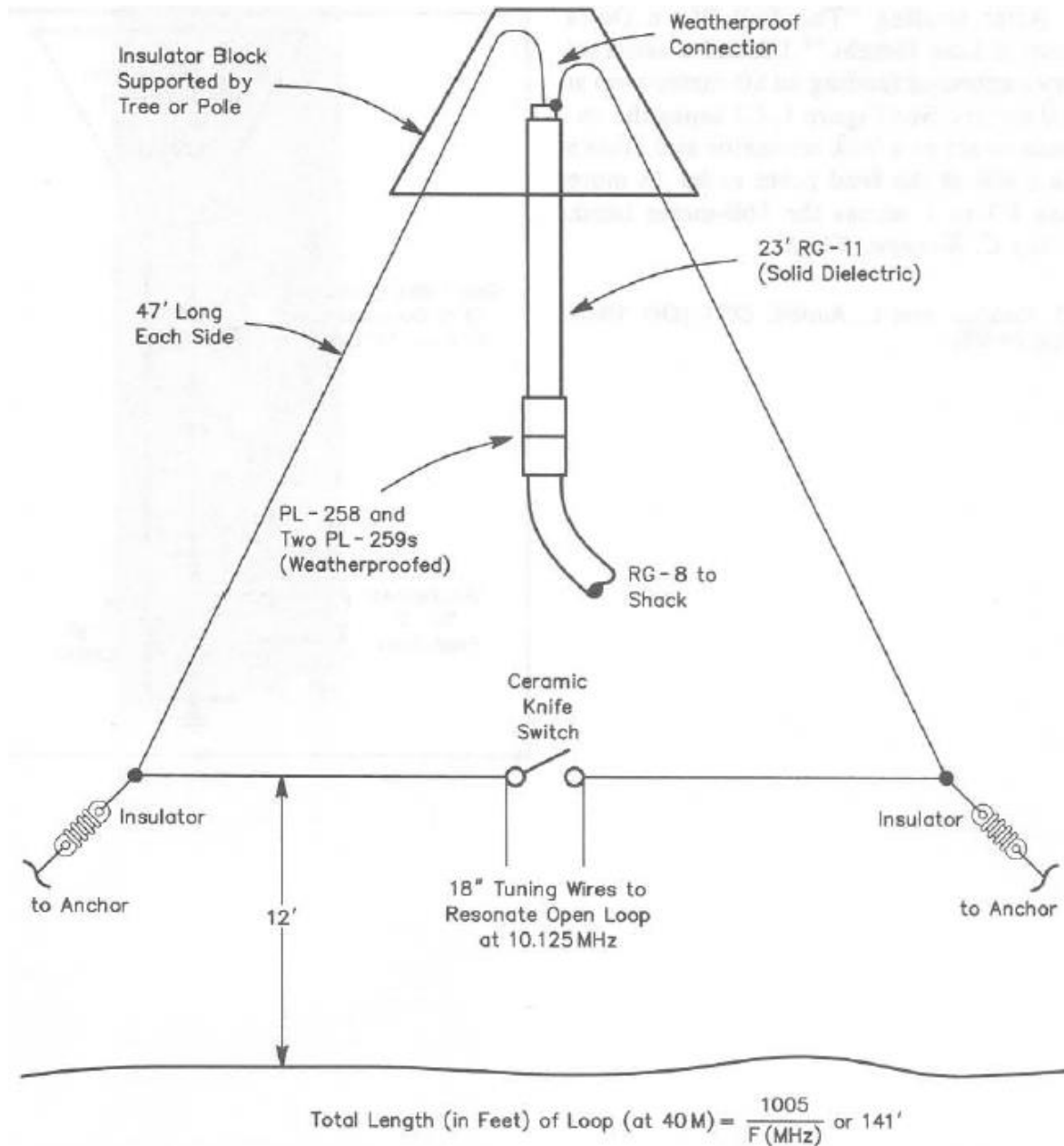

63 - Wire-Beam Antenna for 80m

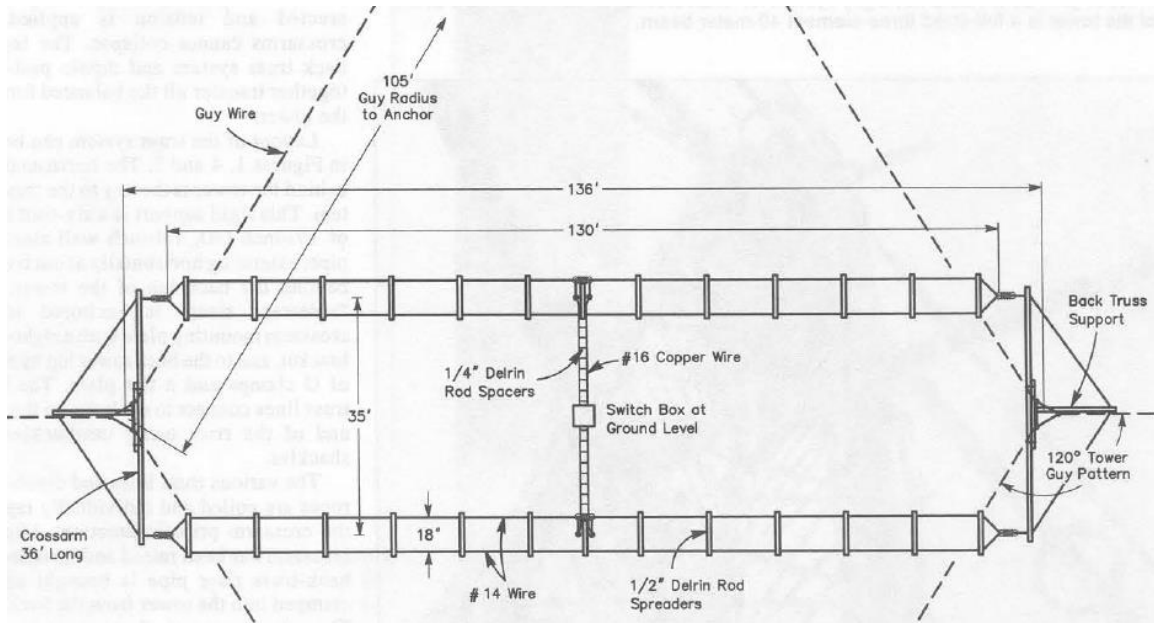

64 - Dual-Band Sloper Antenna

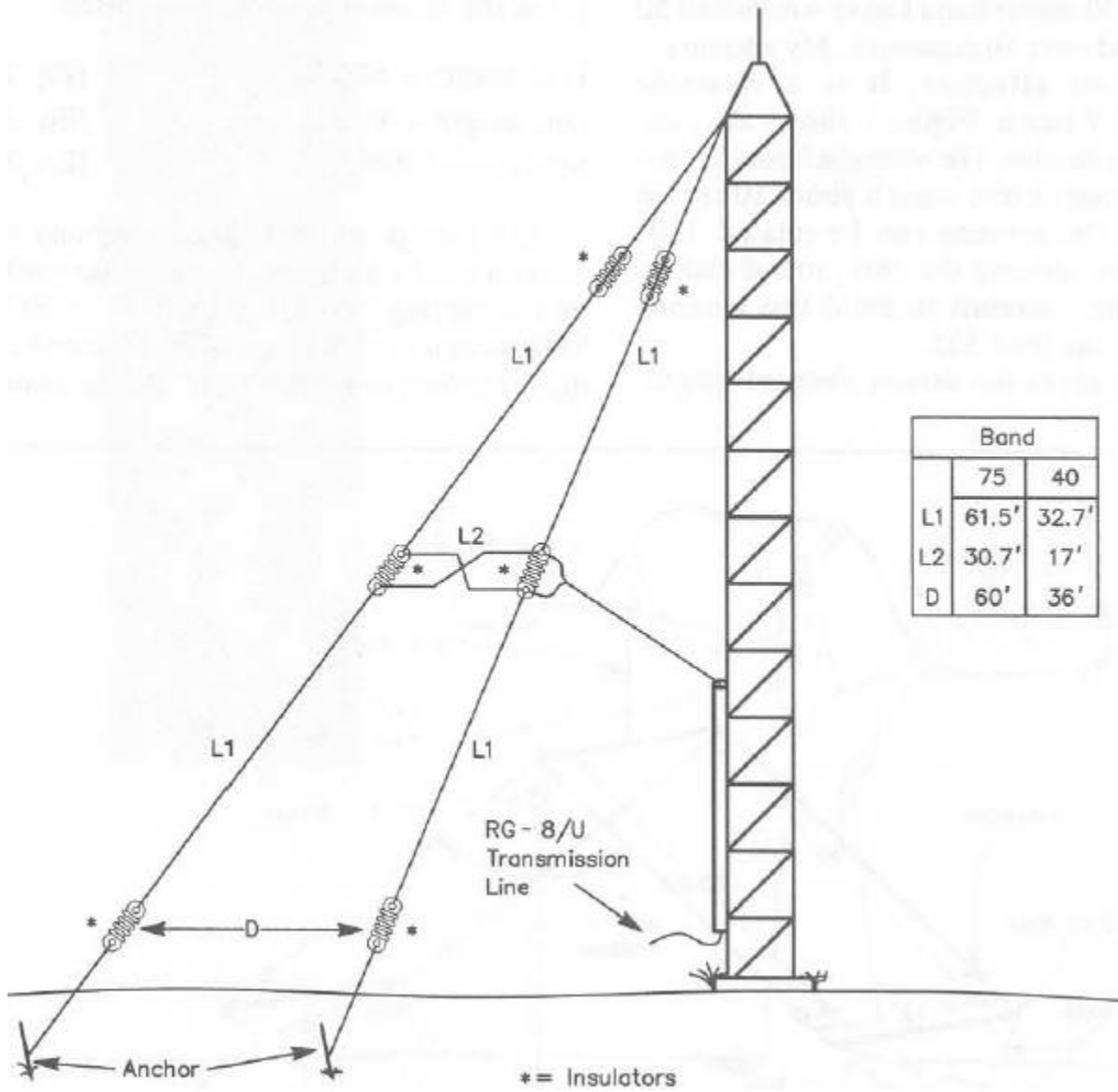

65 - Inverted-V Beam Antenna for 30m

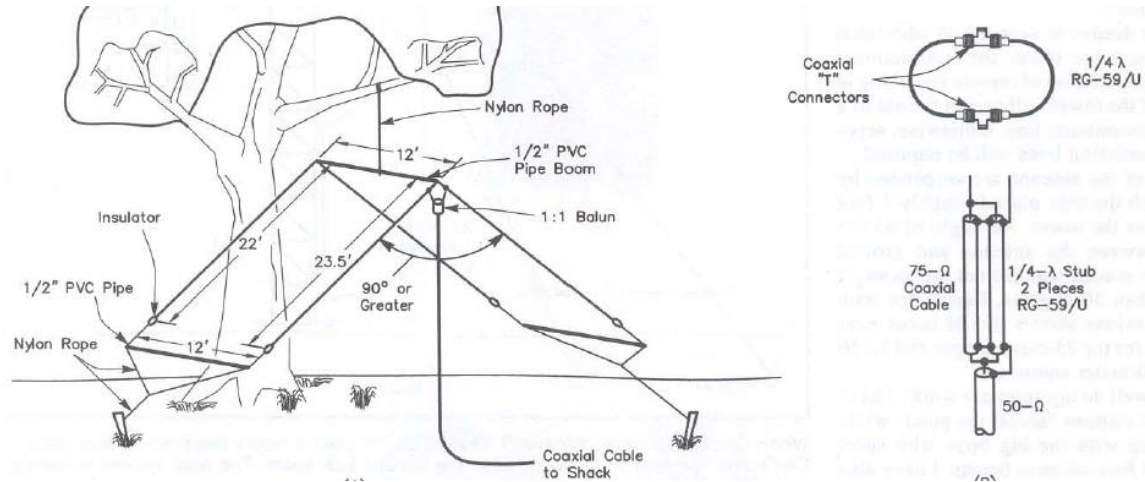

66 - ZL-Special Beam Antenna for 15m

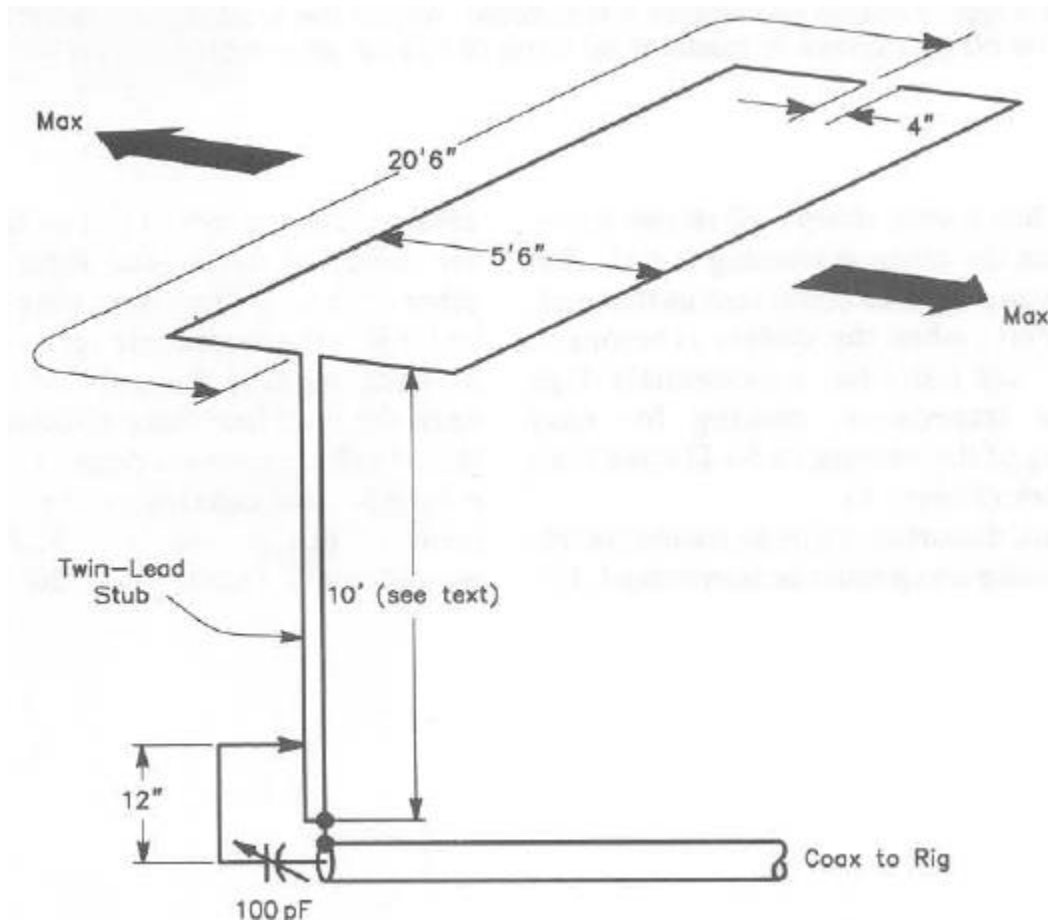

67 - Half-Sloper Antenna for 160m

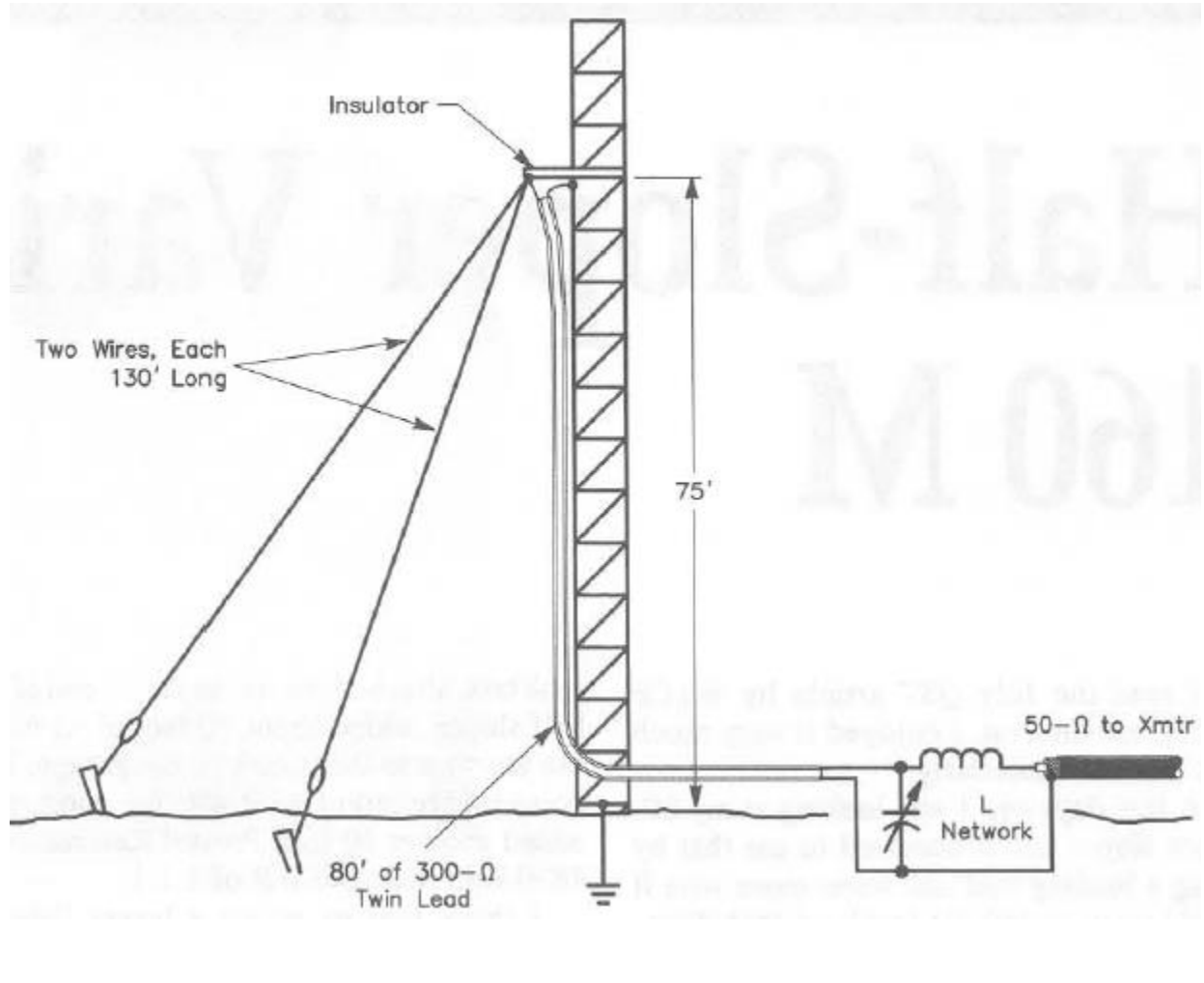

68 - Two-Bands Half Sloper for 80m - 40m

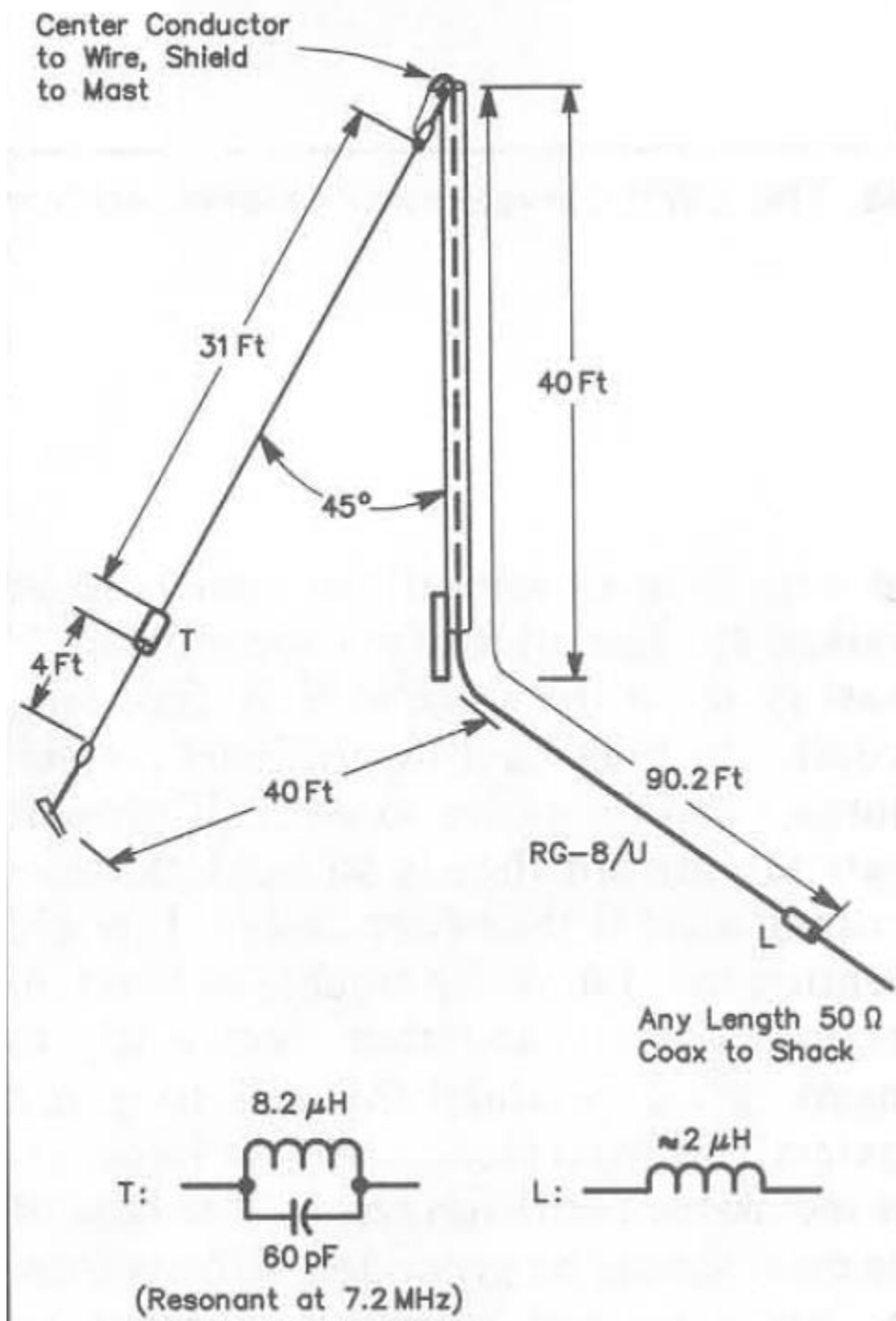

69 - Linear Loaded Sloper Antenna for 160m

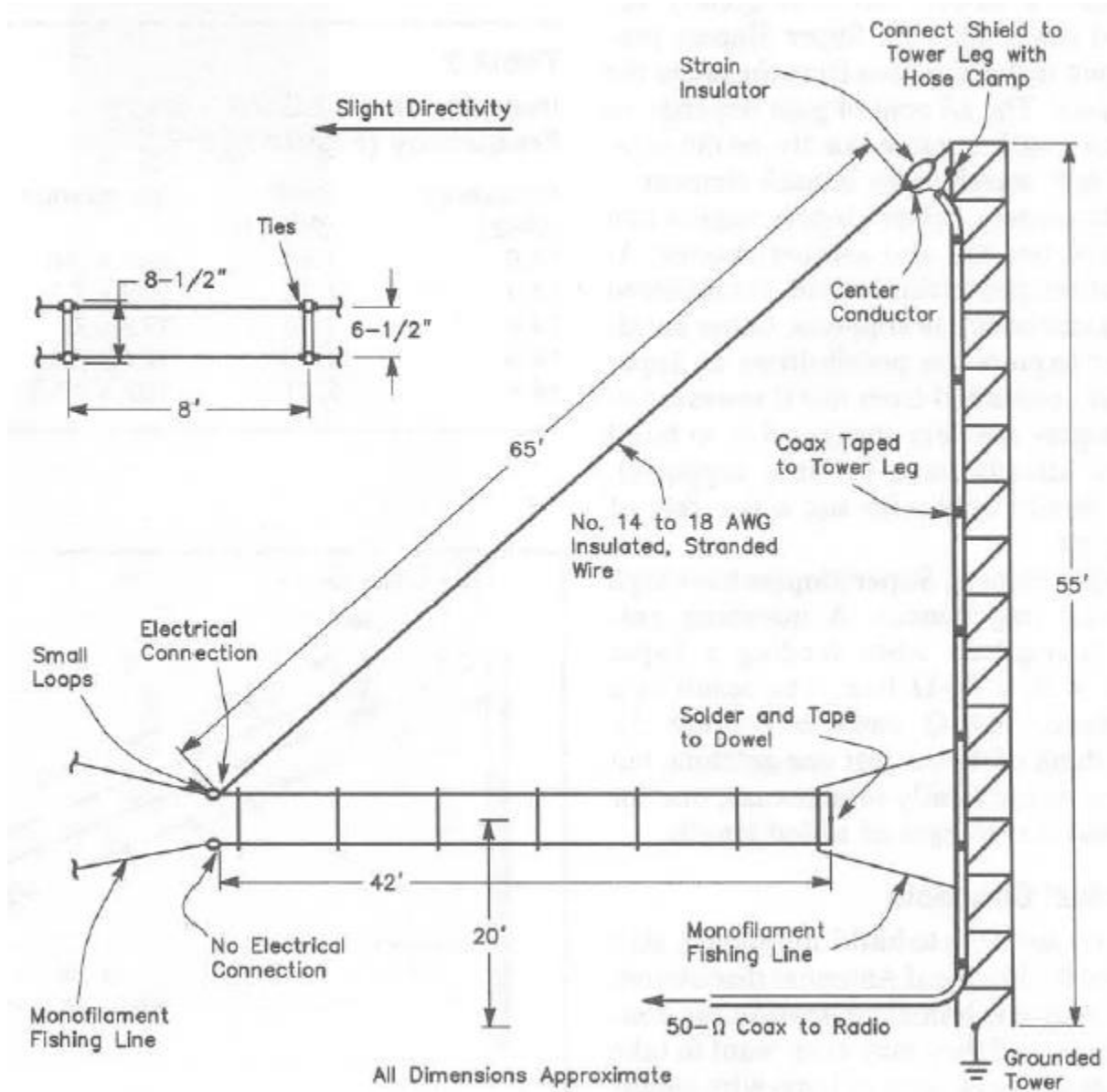

70 - Super-Sloper Antenna

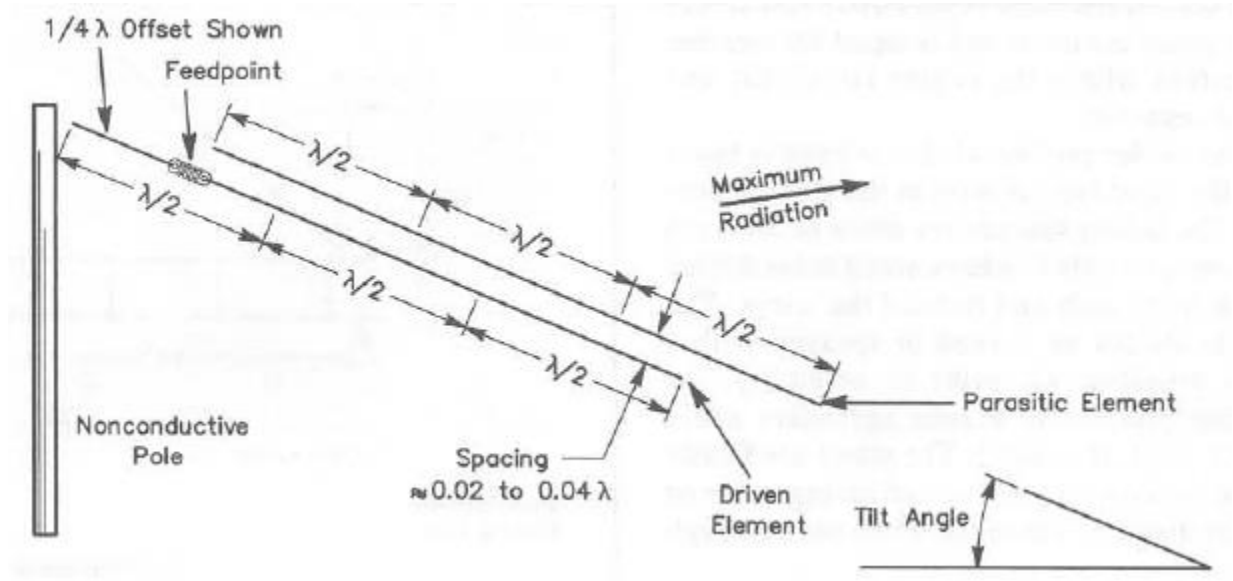

71 - Tower Pole as a Vertical Antenna for 80m

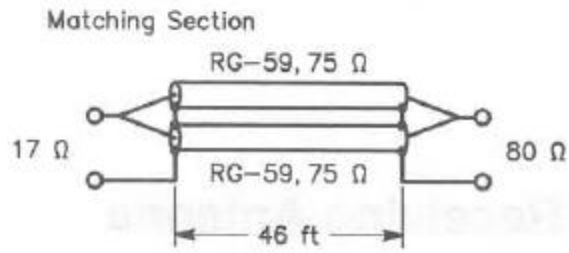
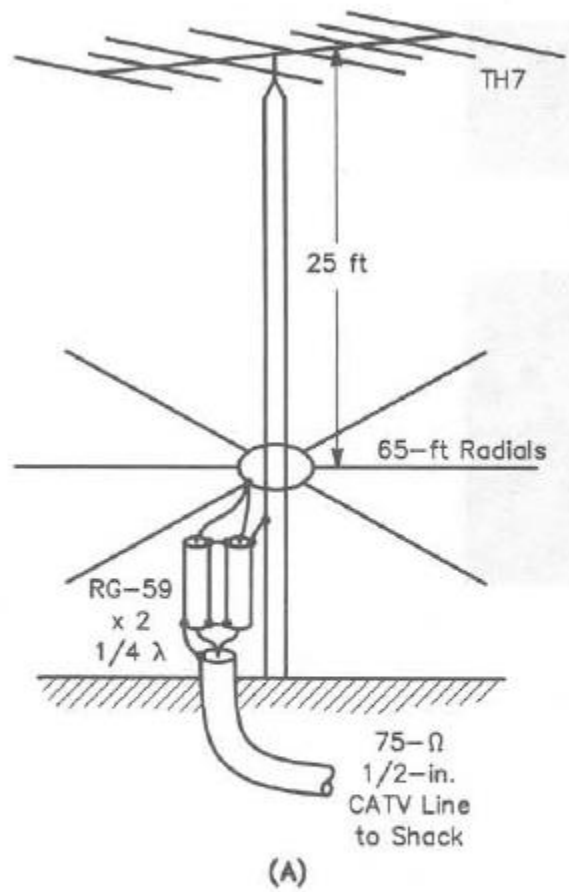

72 - Clothesline Antenna

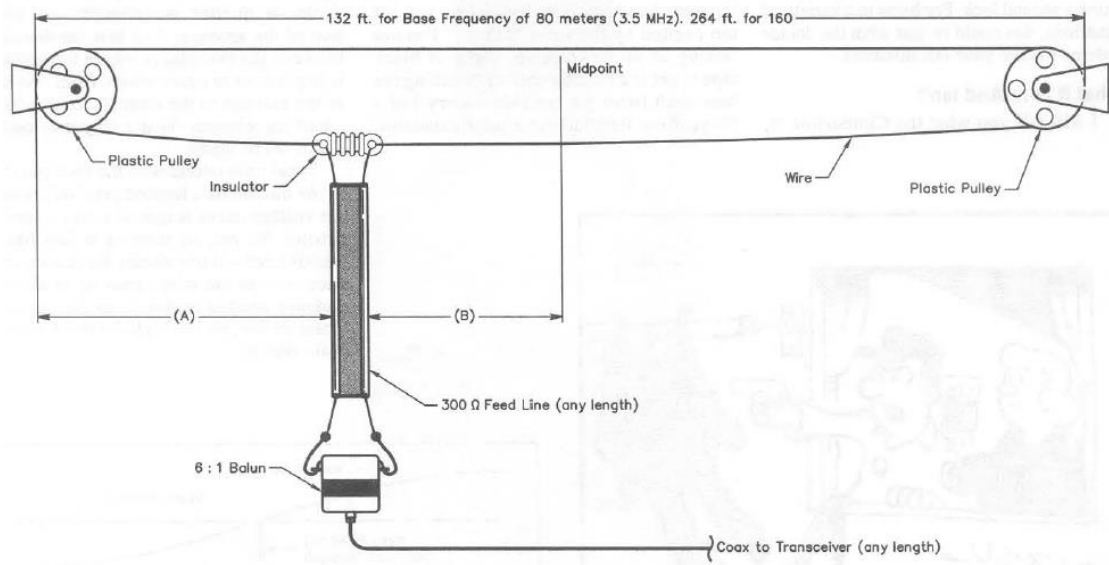

73 - Curtain Zepp Antenna for 160m, 80m, 40m

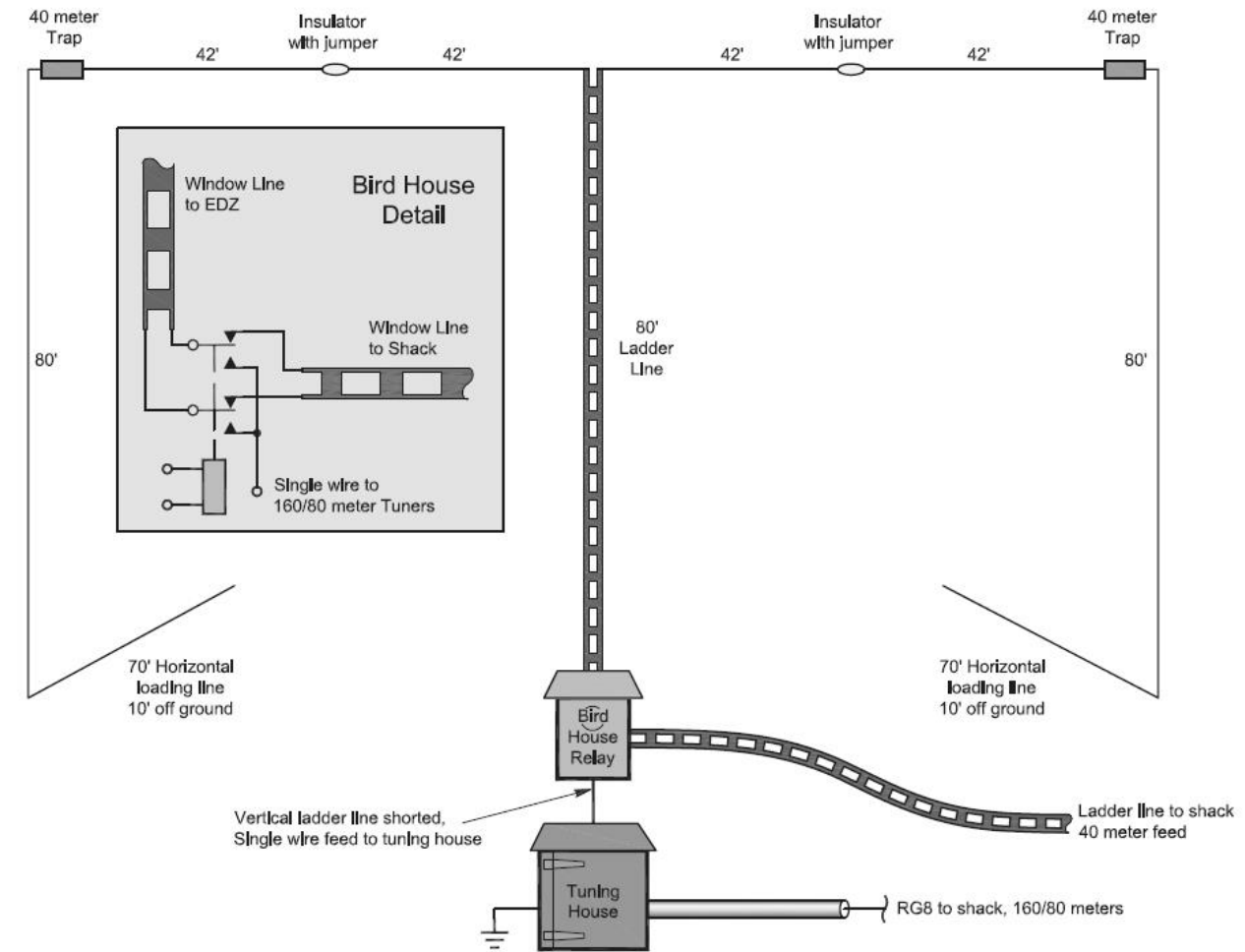

74 - Collinear Array Antenna for 40m, 30m, 20m

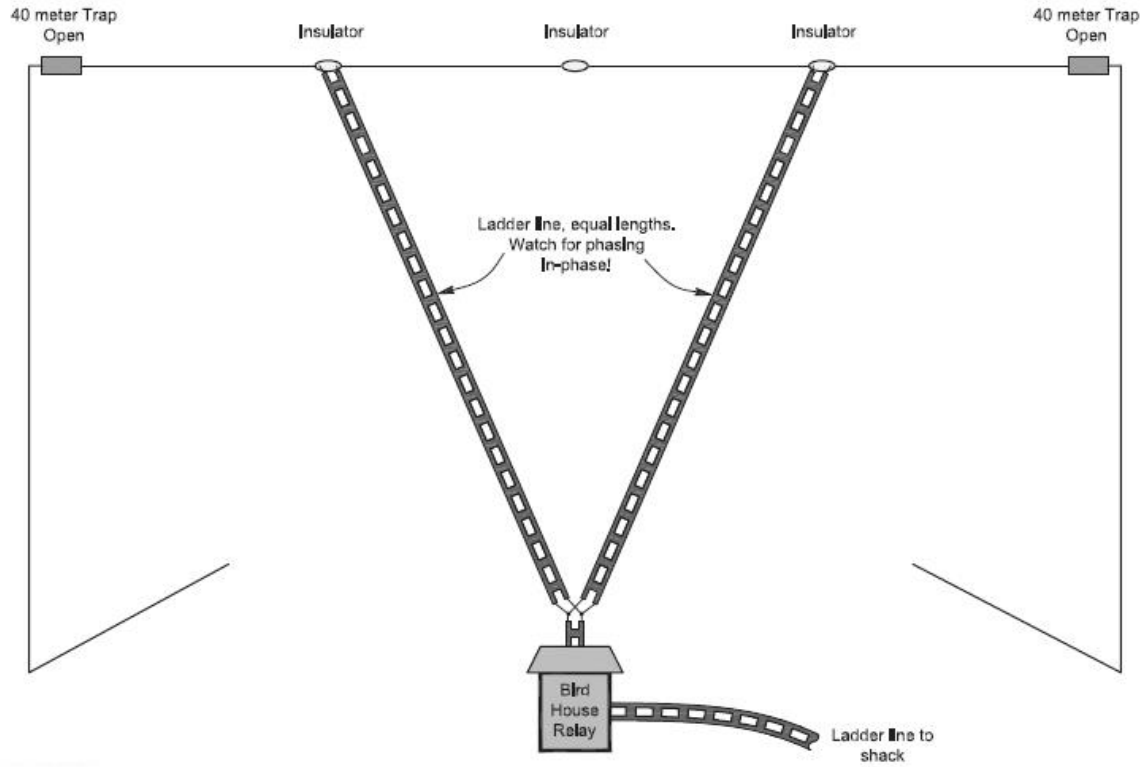

75 - 160m Inverted Delta Loop

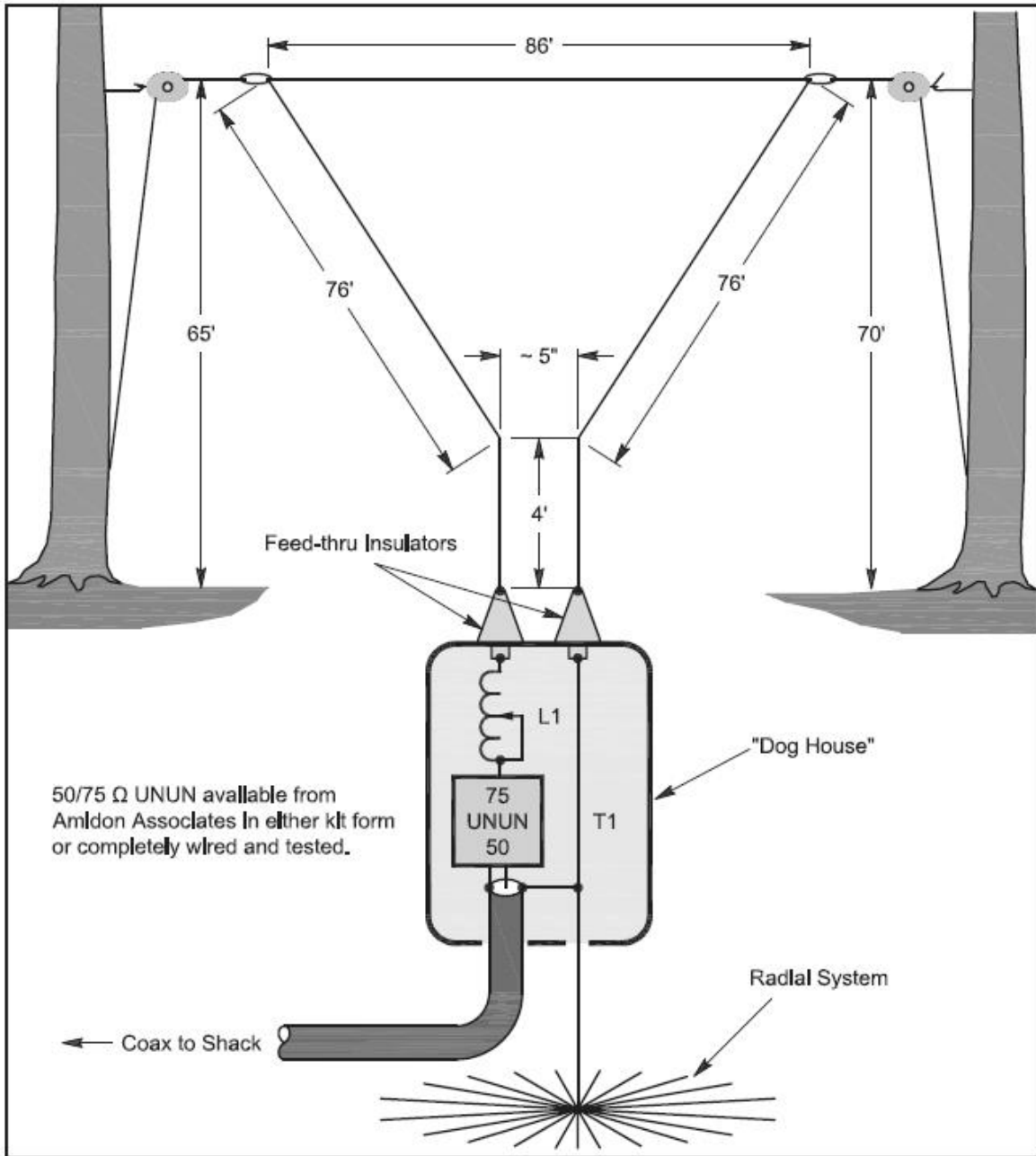

76 - Half Rhombic Unidirectional Vertical for 20m to 6m

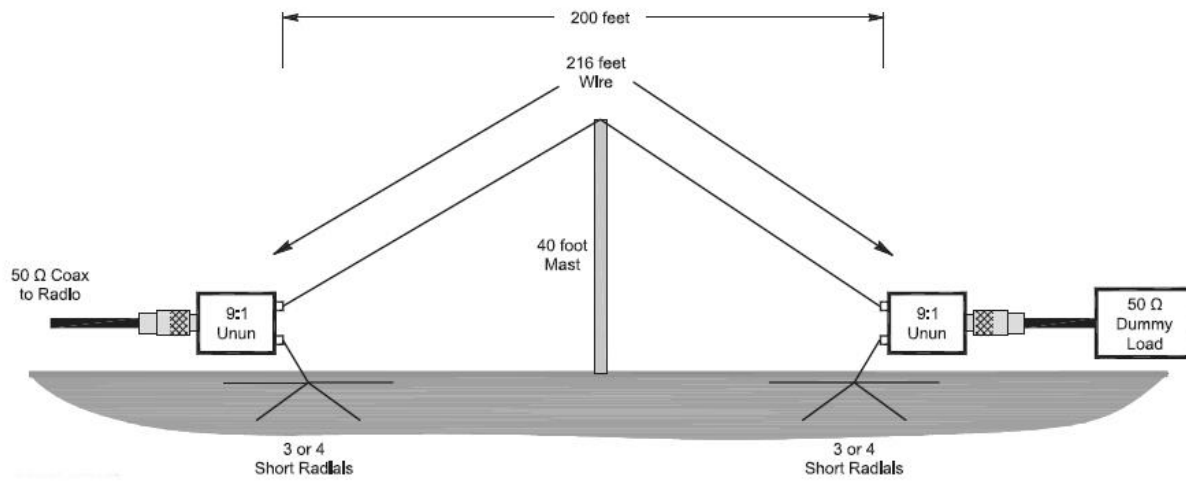

77 - Capacitance Loaded Vertical Antenna for 160m

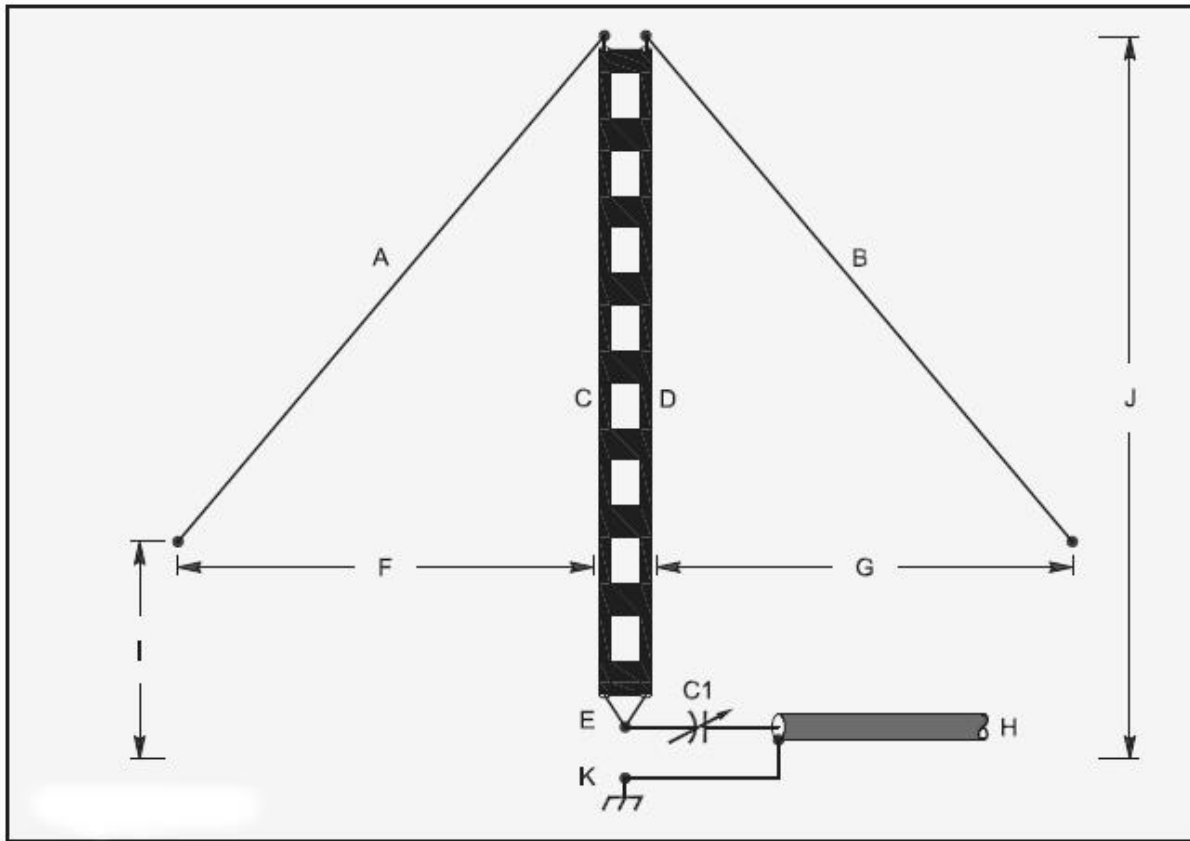

C1 — Variable capacitor, 0-1500 pF, 7 kV.

A, B — Sloping segments of 66 foot, 4 inch pieces of #16 AWG enameled copper wire soldered to the top of segments C and D and forming a 45° angle.

C, D — 59 feet of 450 Ω open wire or window line or, alternatively, two parallel lengths of #16 AWG enameled copper wire with a 1 inch separation.

E — 1 inch triangle formed by the bottom ends of the open wire line. Solder them tightly at the vertex and connect to C1.

F, G — Distance between the lower ends

of segments A and B from segments C and D, 51 feet.

H — Any length of 50 Ω coaxial cable (RG-213 in this case). The central conductor must be soldered to C1, and the braid to the ground radials.

I — Approximately 16 feet from ground to lower ends of sloping segments A and B.

J — 60 feet from antenna top to bottom.

K — Ground radials, $60 \frac{1}{4} \lambda$ (the more the better — 32 will form a reasonable ground).

78 - Fan Dipole Antenna for 80m to 6m

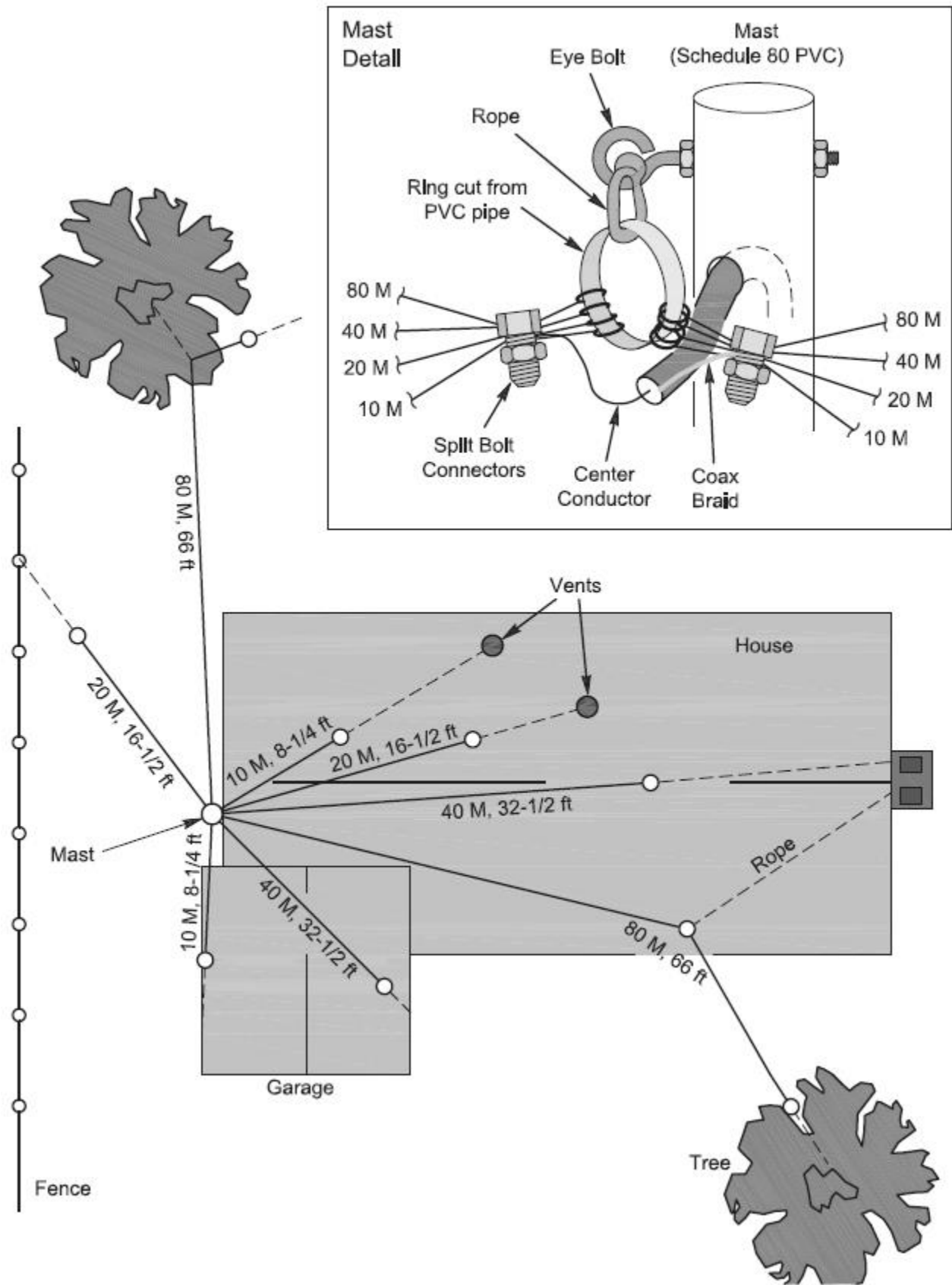

79 - Wire Ground Plane Antenna

The lengths of all 3 sides is determined by the formula of a 1/4 wave antenna

This antenna configuration will work for all frequencies from 160 meters to VHF.

$$\text{Length (in feet)} = \frac{234}{\text{frequency in MHz}}$$

The vertical side uses the inner conductor of the coax. On the Budwig the is the side the shows a "+" (plus sign). The outer (lower) legs use the outer braid or the "-" (minus sign).

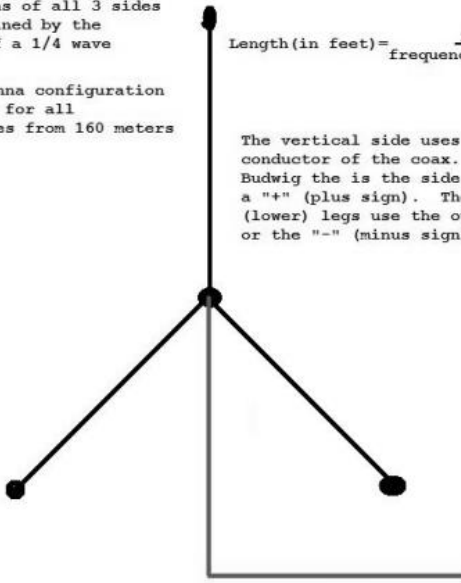

SO-239 Chassis mount, 4 hole

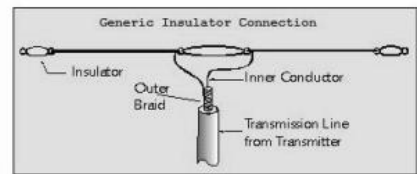

80 - Inverted Delta Loop Antenna for 160m

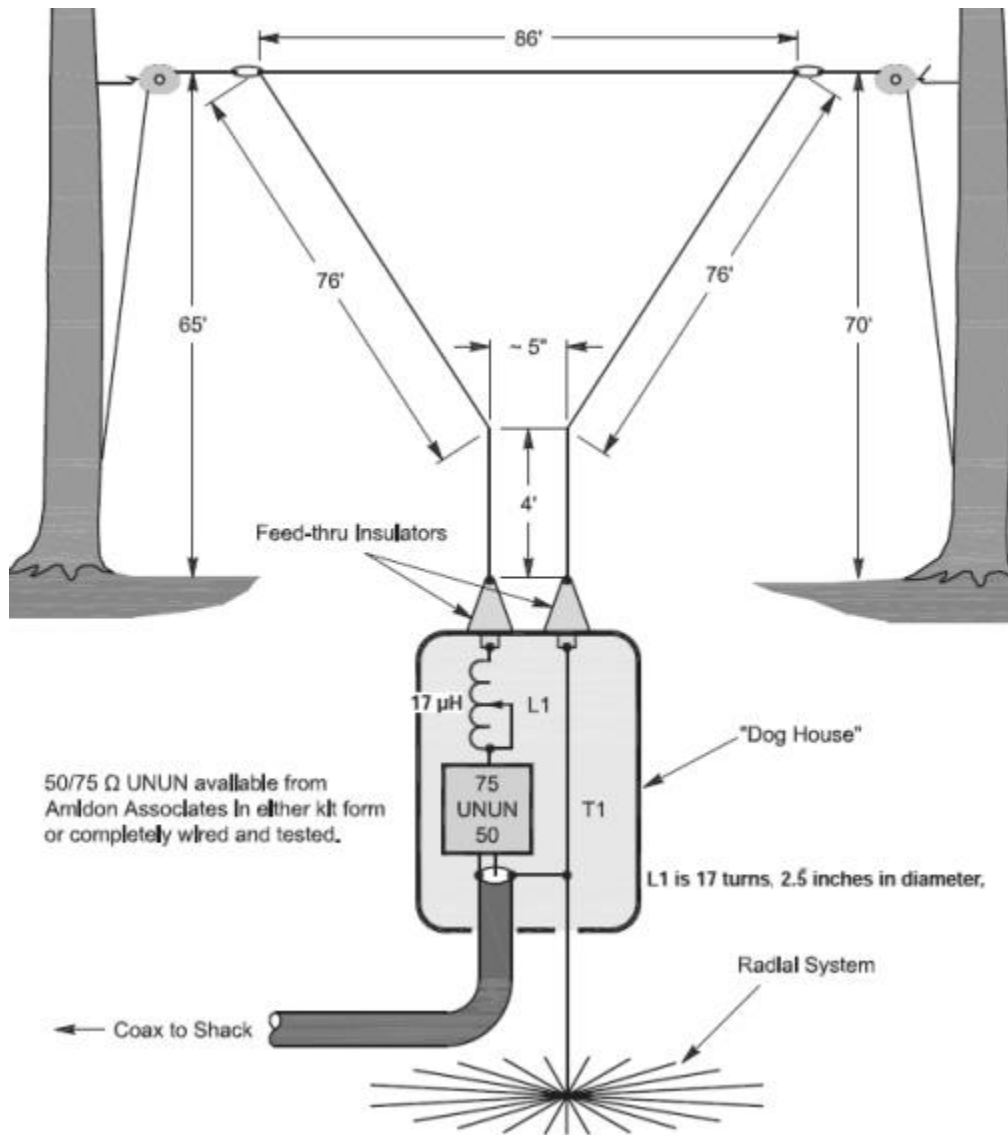

81 - Inverted-L for 160m

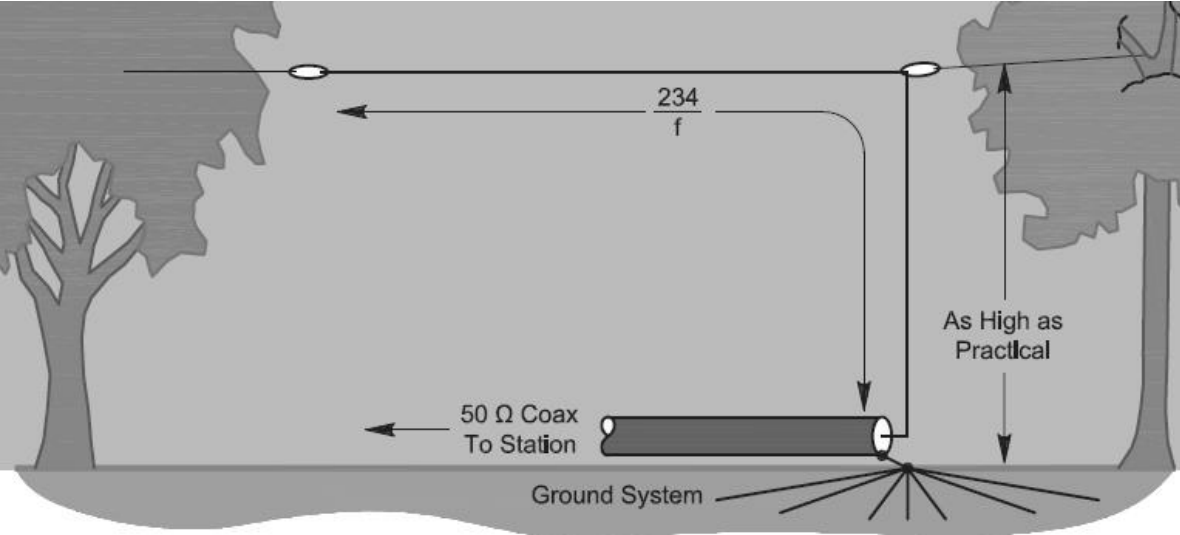

82 - 300ohm-Ribbon Dual Band Dipole

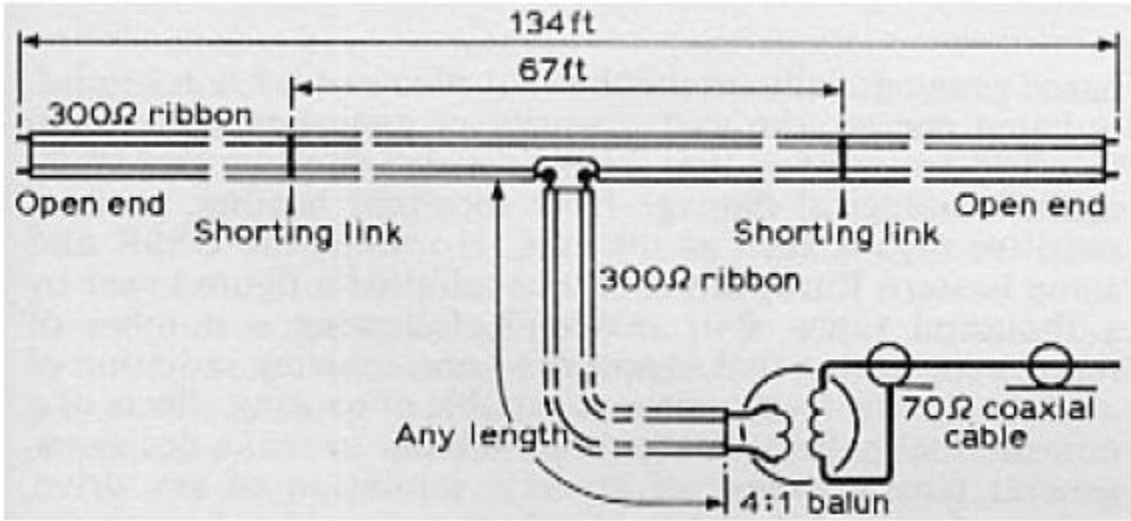

83 - Tri-Band Beam for 20m, 15m, 10m

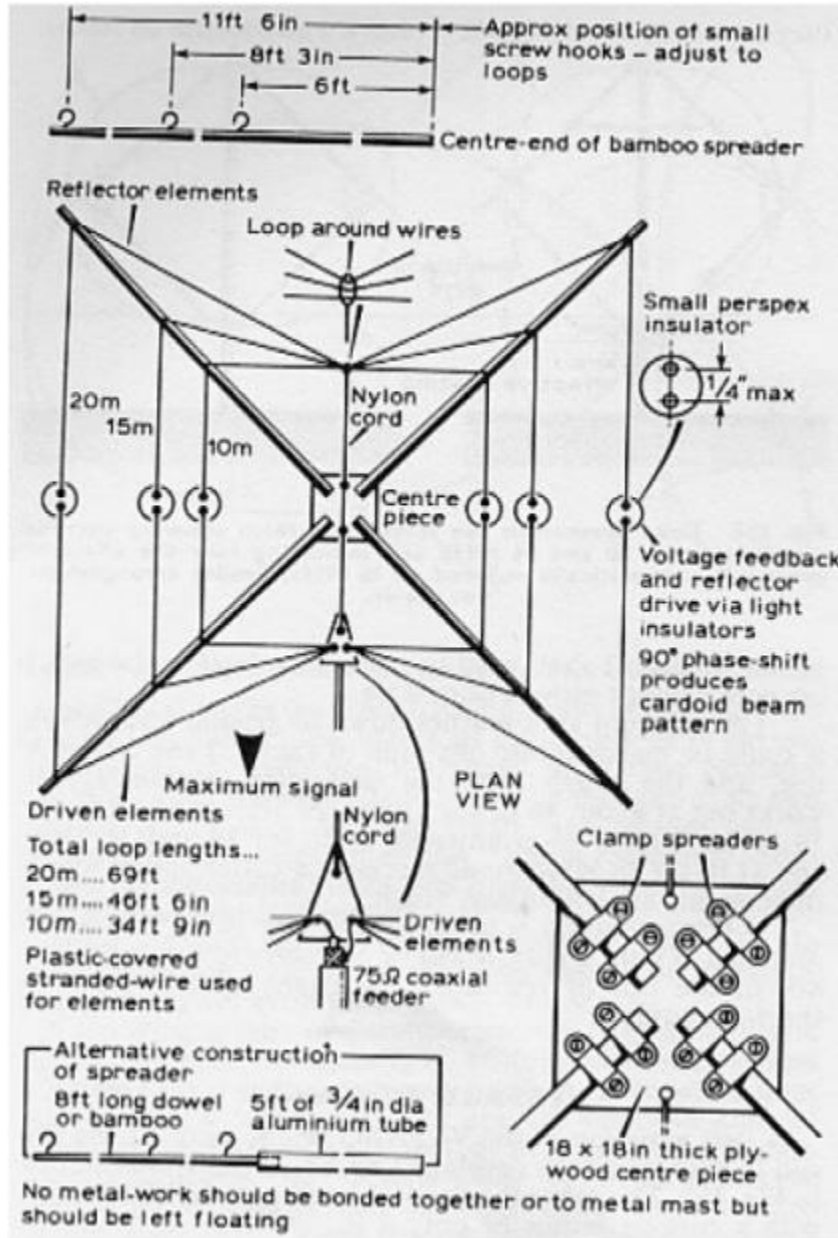

84 - Mini-Horse Yagi Antenna

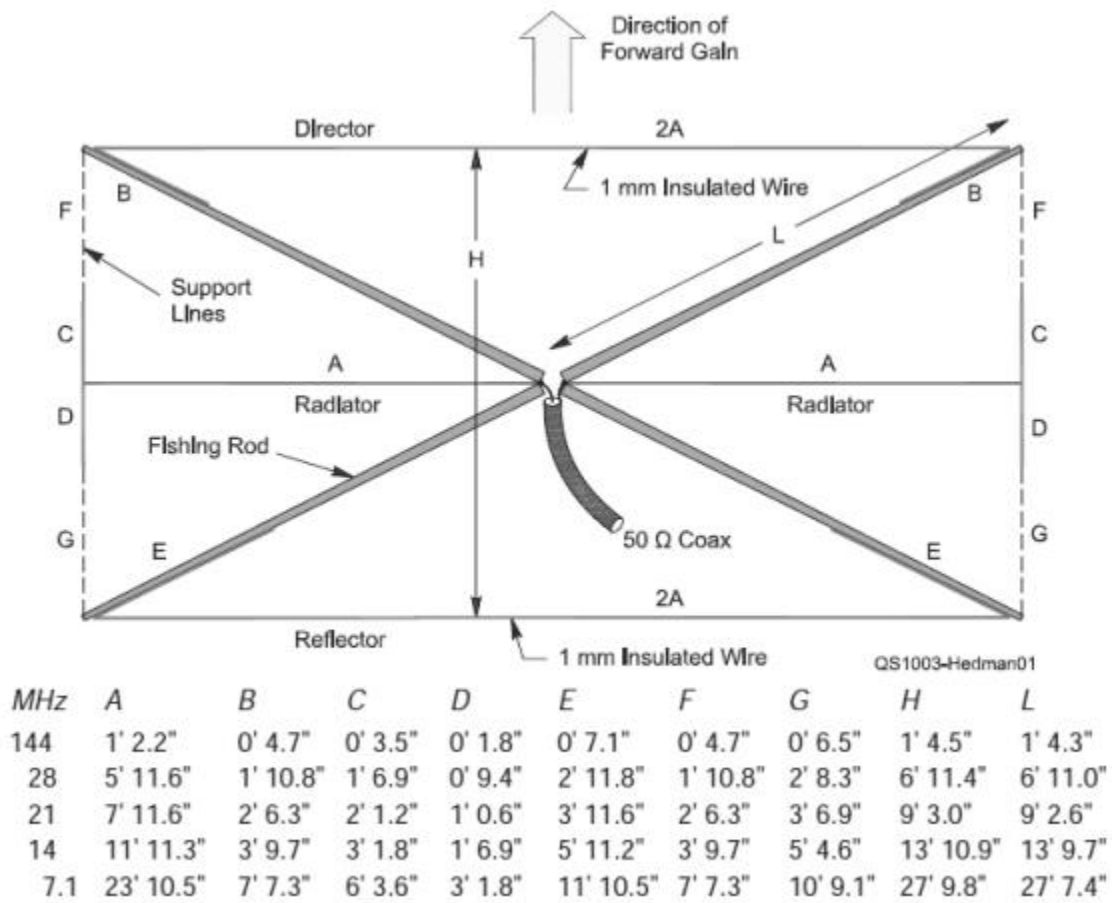

85 - Half-Rhombic Directive Antenna for 20m to 6m

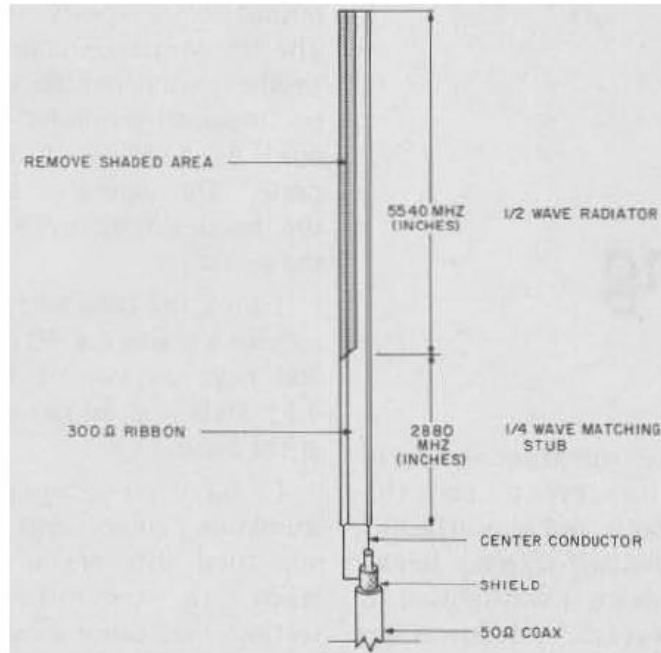

Frequency (MHz)	28.0	28.5	29.0	50.0	51.0	52.0	144	145	146	147
Radiator (inches)										
1/2 wave	197.8	194.3	191.0	110.8	108.6	106.5	38.4	38.2	37.9	37.7
Stub (inches)										
1/4 wave	102.8	101.0	99.3	57.6	56.4	55.3	20.0	19.8	19.7	19.6

86 - Fan-Dipole Antenna for 80m, 40m, 20m

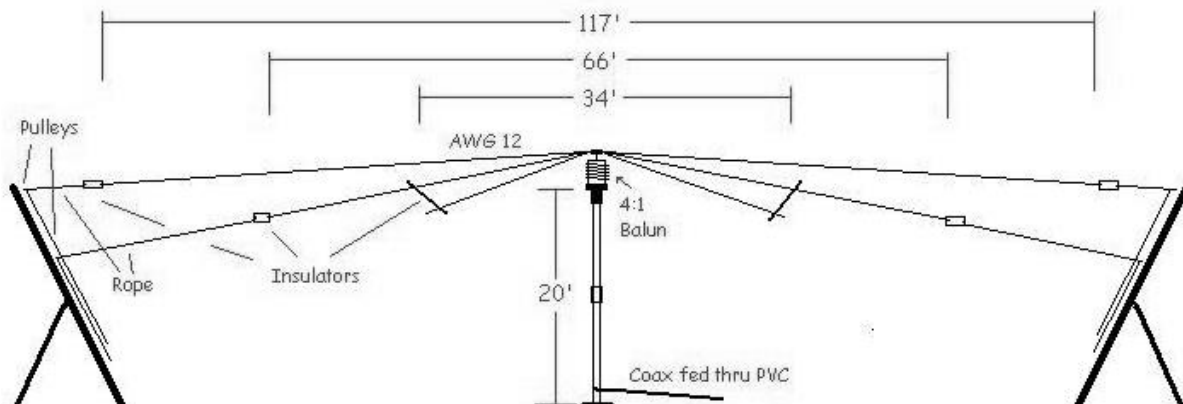

87 - Capacity Tuned Folded Loop Antenna for 20m

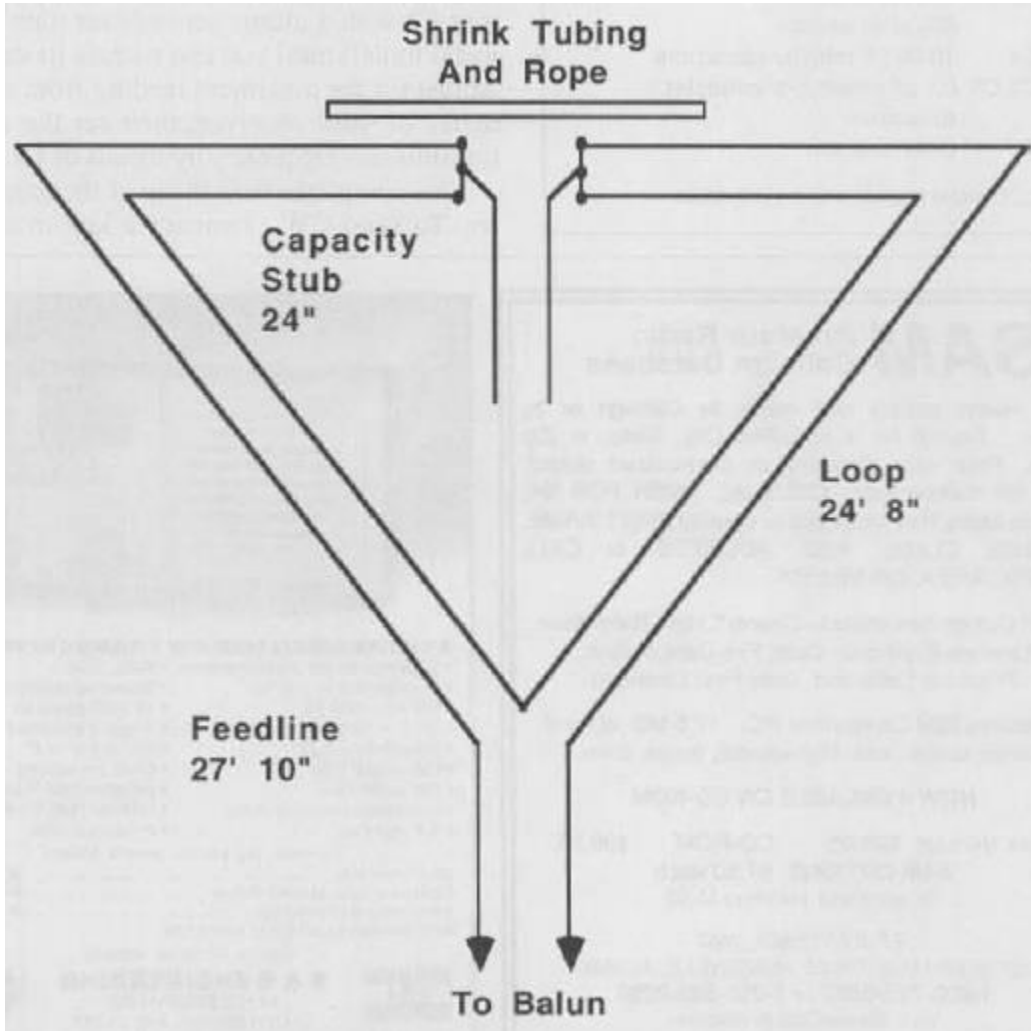

88 - Indoor Loop Antenna for 80m to 30m

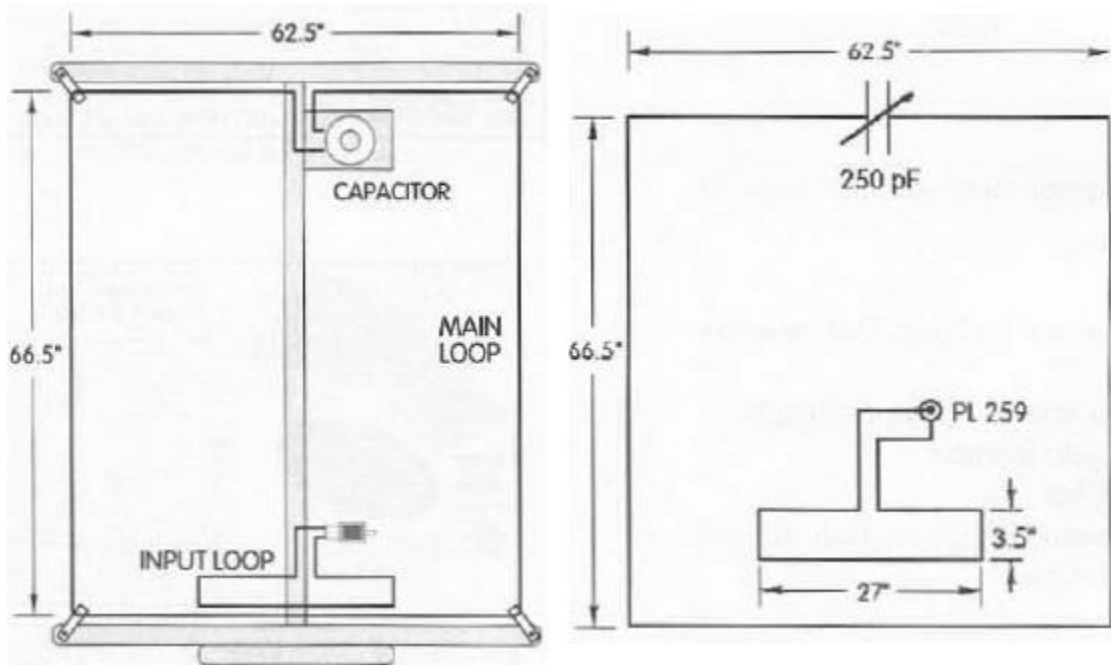

89 - Indoor Loop Antenna for 80m

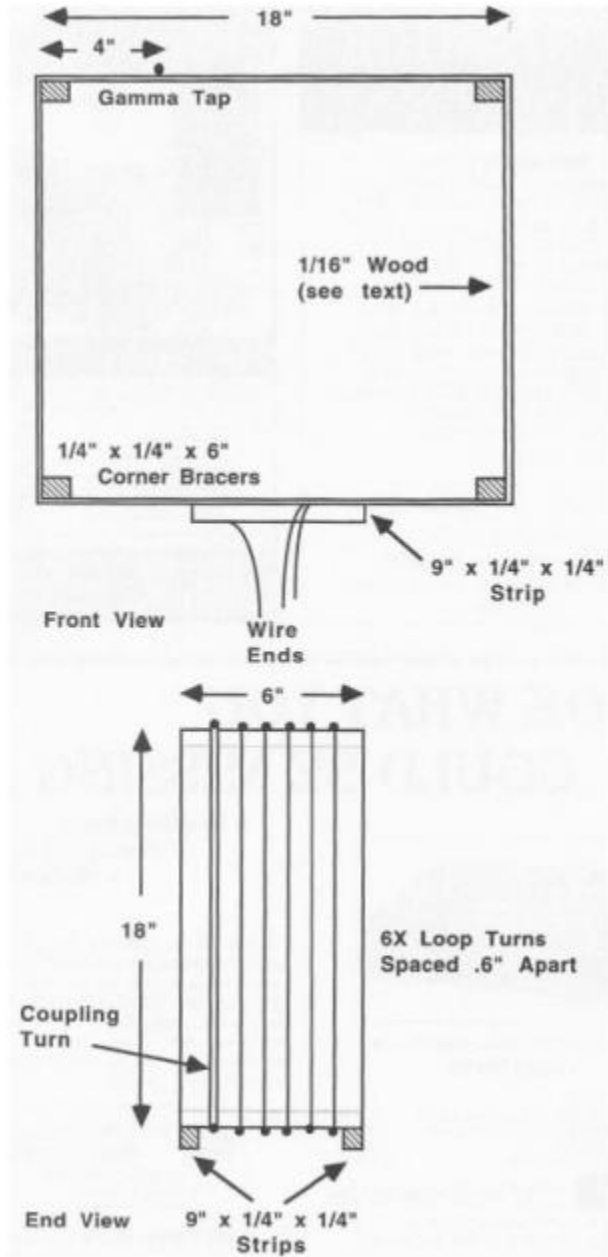

90 - Double-Delta Antenna 80m and 40m

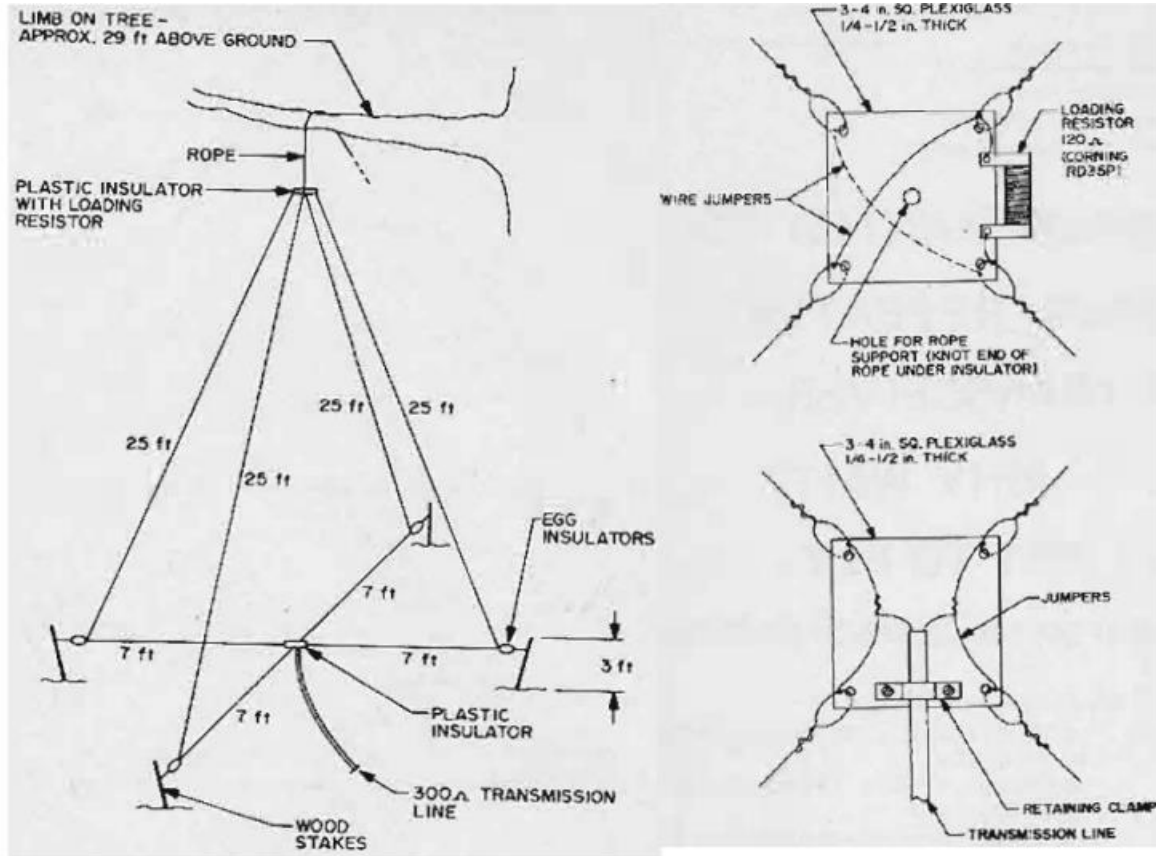

91 - Inductance-Loaded Shortened Dipole for 160m

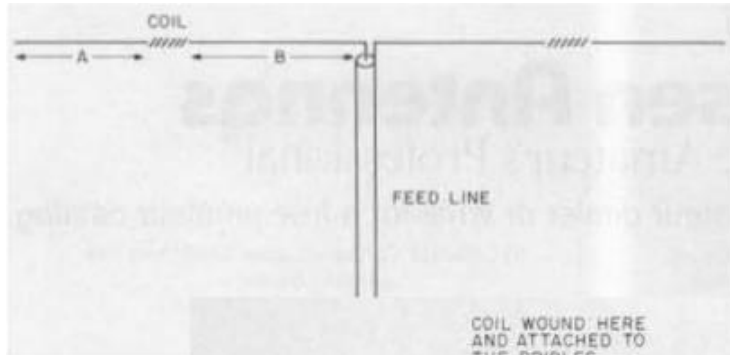

Overall Length (ft.)	Element A Length	Number Of Coil Turns	Element B Length
246.3	full-size antenna		
221.3	66.5	10	44.3
197.1	59.1	20	39.4
172.4	51.7	33	34.5
147.8	44.3	48	29.6
123.2	36.9	65	24.6
98.5	29.6	86	19.7

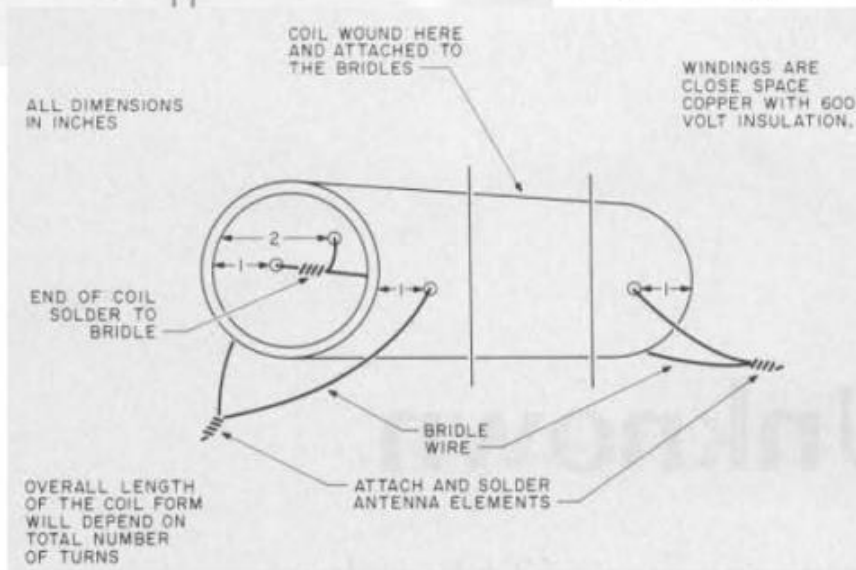

92 - V-Beam Antenna for 15m

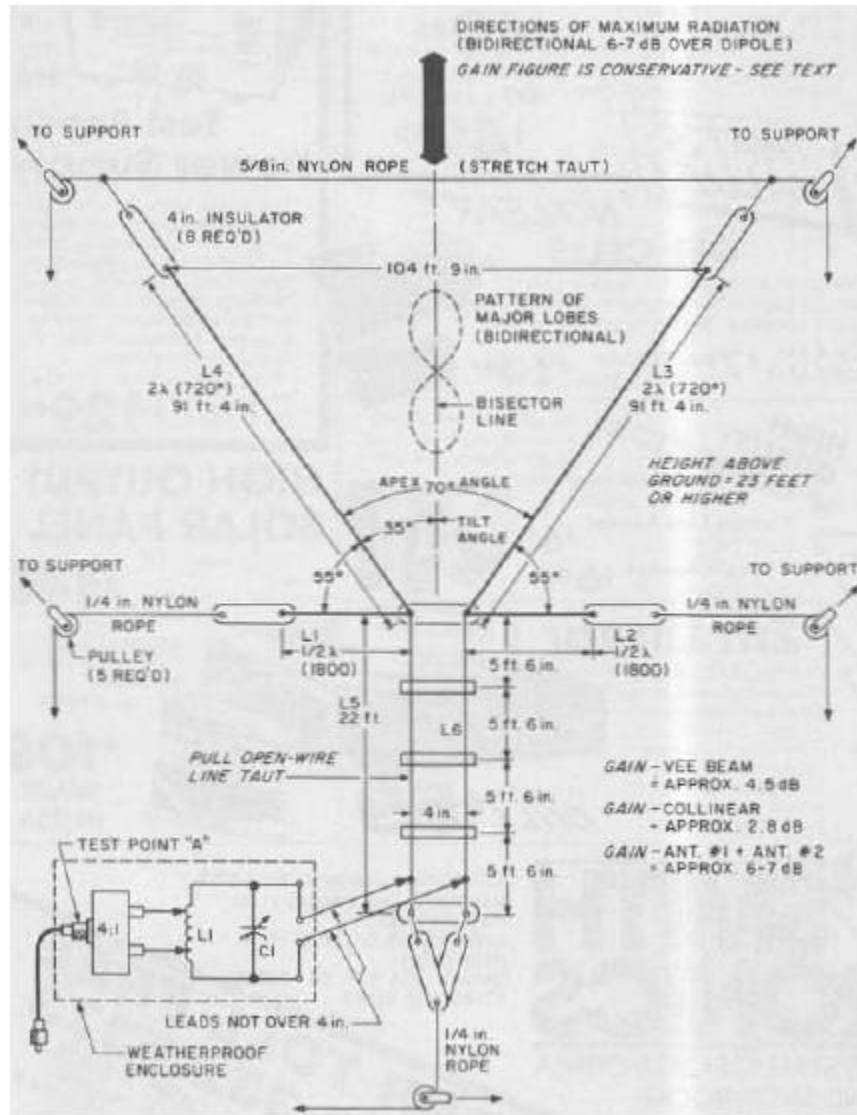

93 - Picnic Vertical Wire Antenna

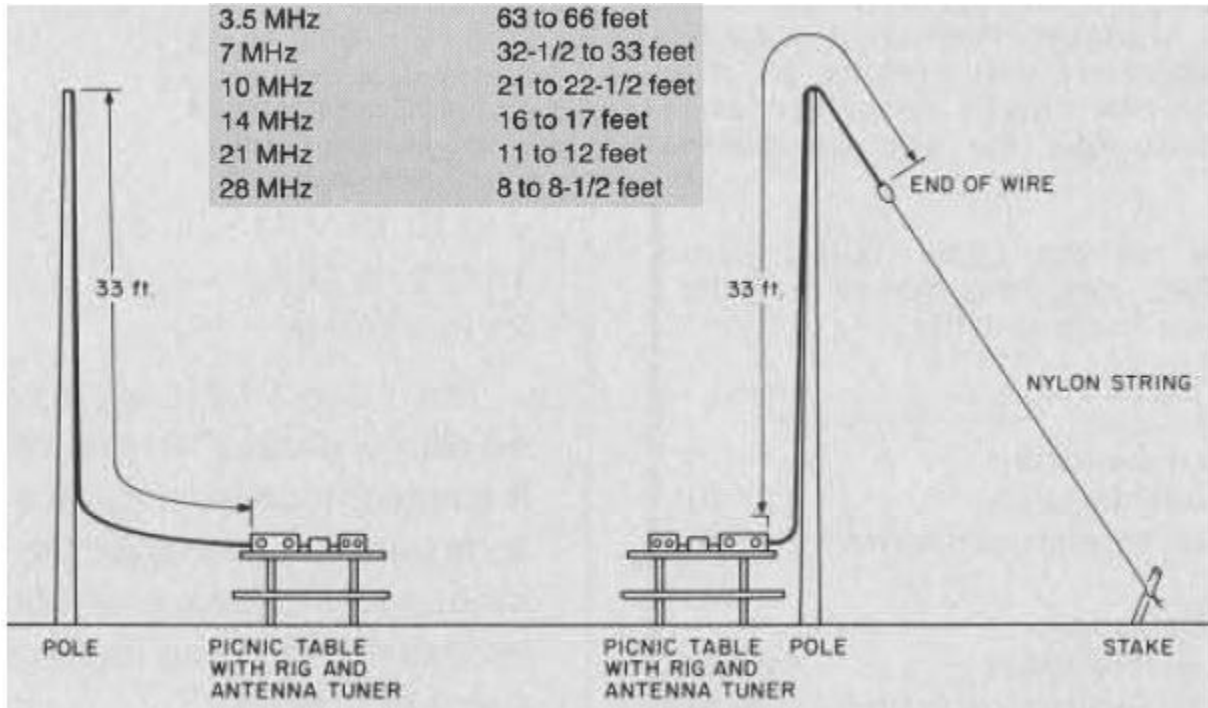

94 - Laid-Back Quad Antenna for 80m

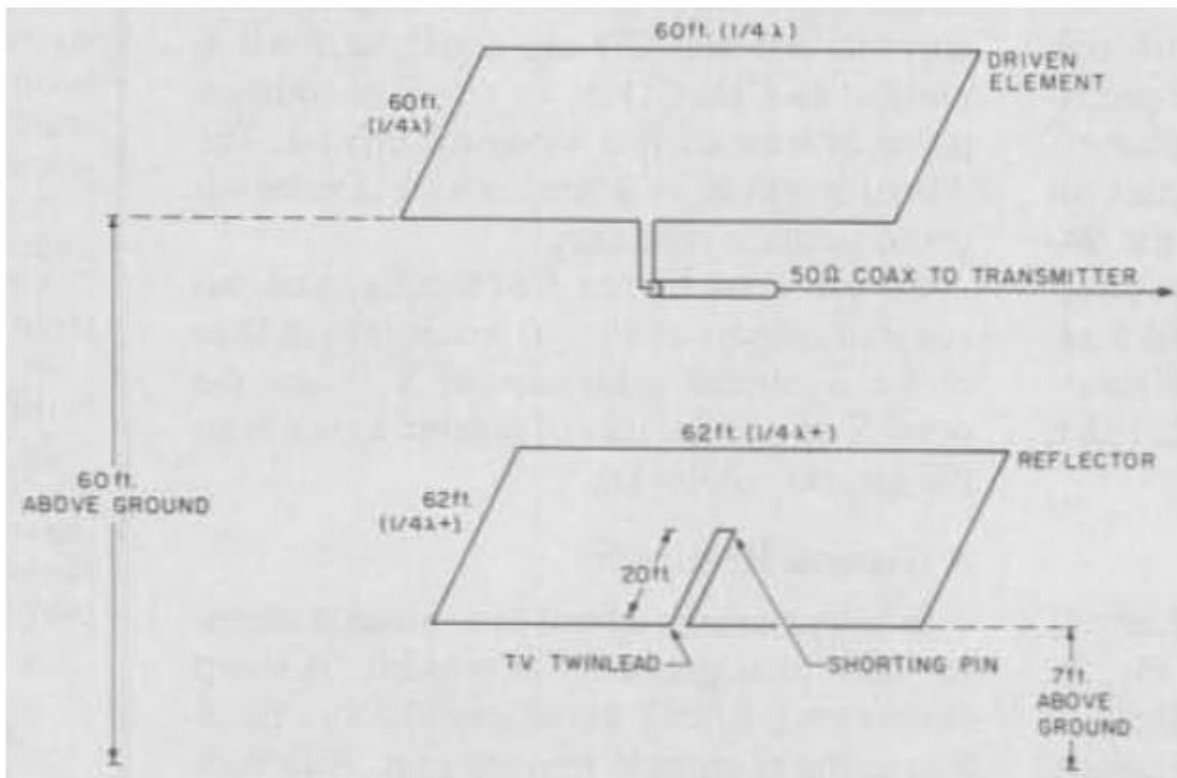

95 - Phased Loop Antenna

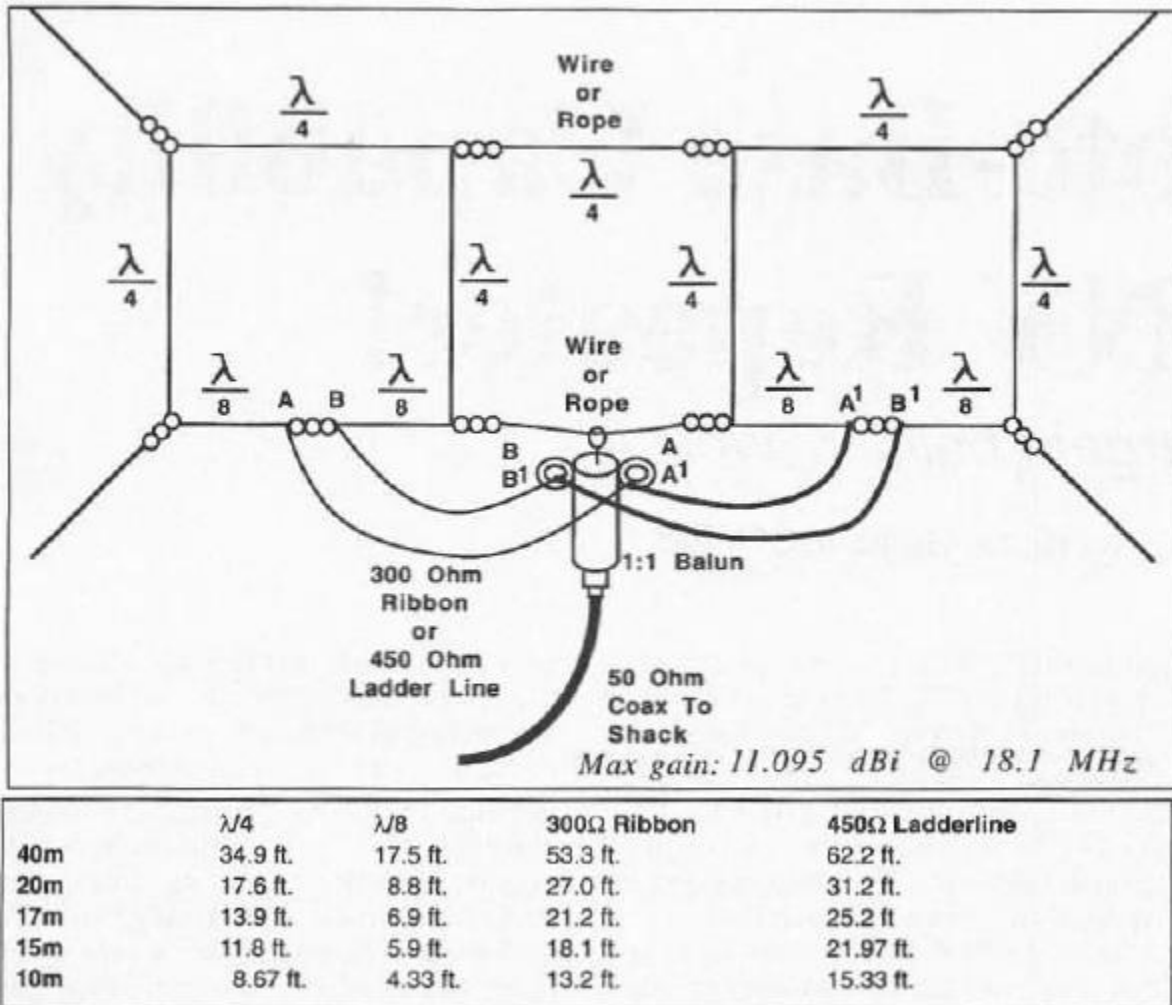

96 - Loop Antenna for TX for 160m

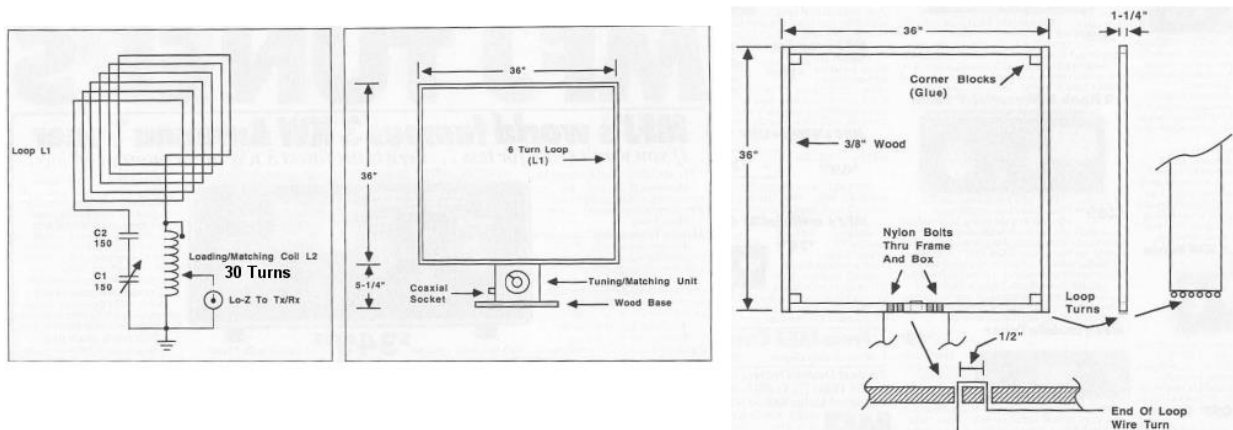

97 - Morgain-Dipole Antenna for 160m and 80m

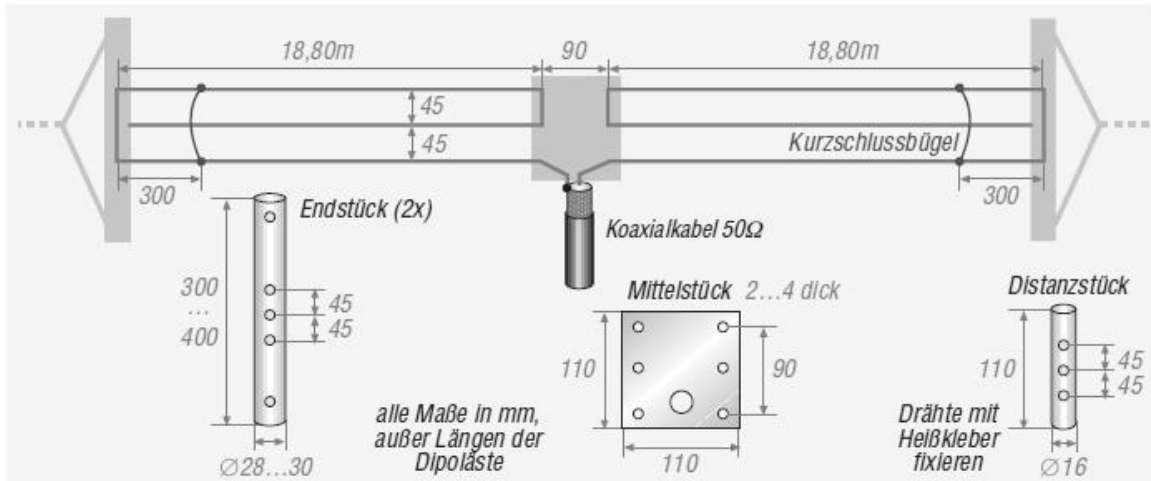

98 - ZL-Special for 20m, 15m, 10m

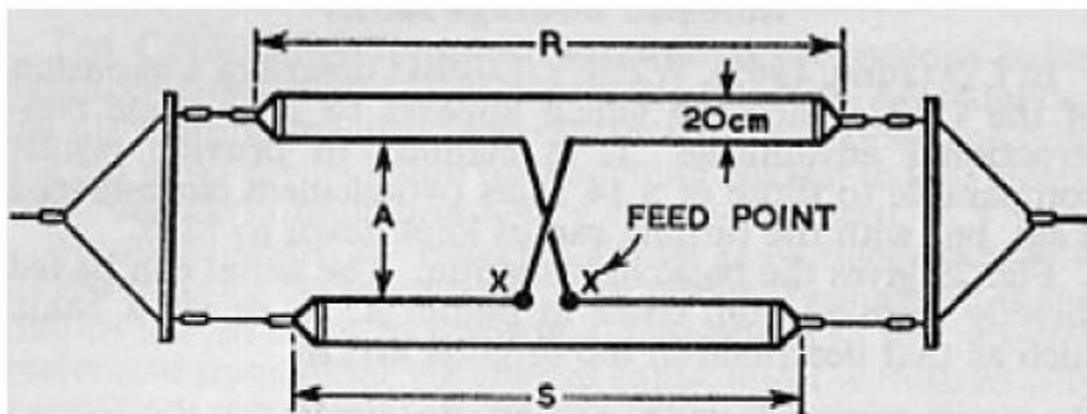

	S	R	A	A
28 Mc/s	5.09m	5.39m	1.29m	$\frac{1}{2}\lambda$
	4.17m	4.42m	1.06m	$\frac{1}{10}\lambda$
21 Mc/s	6.85m	7.24m	1.72m	$\frac{1}{2}\lambda$
	5.62m	5.94m	1.41m	$\frac{1}{10}\lambda$
14 Mc/s	10.30m	10.85m	2.58m	$\frac{1}{2}\lambda$
	8.45m	8.90m	2.12m	$\frac{1}{10}\lambda$

99 - Biconical Antenna

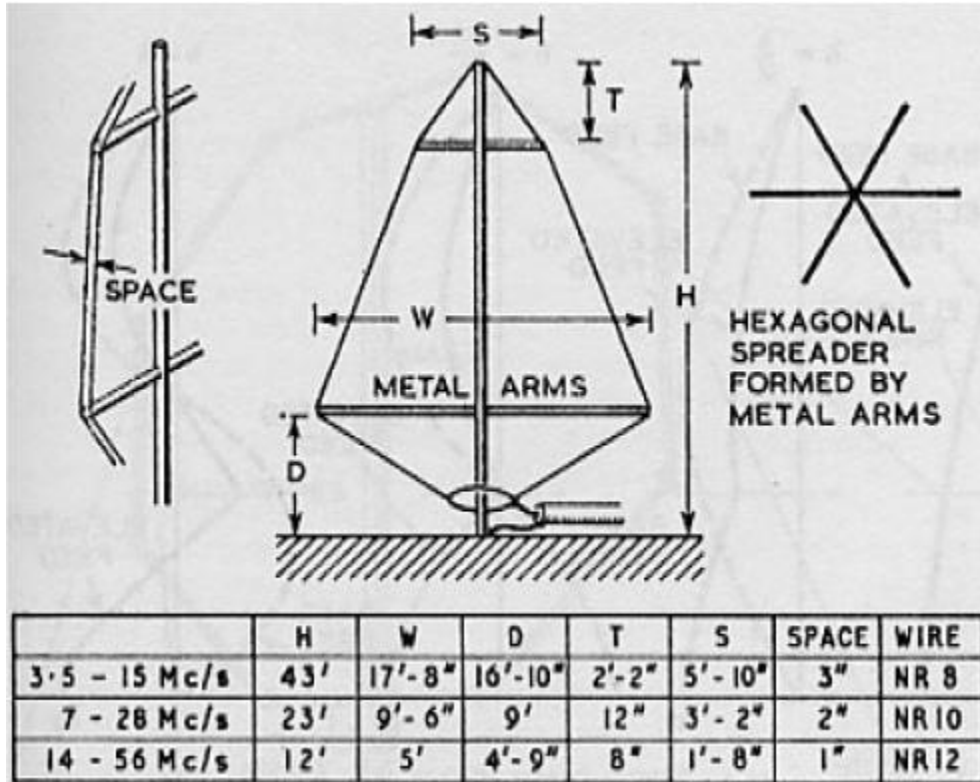

100 - Directive Delta-Birdcage Antenna for 20m to 10m

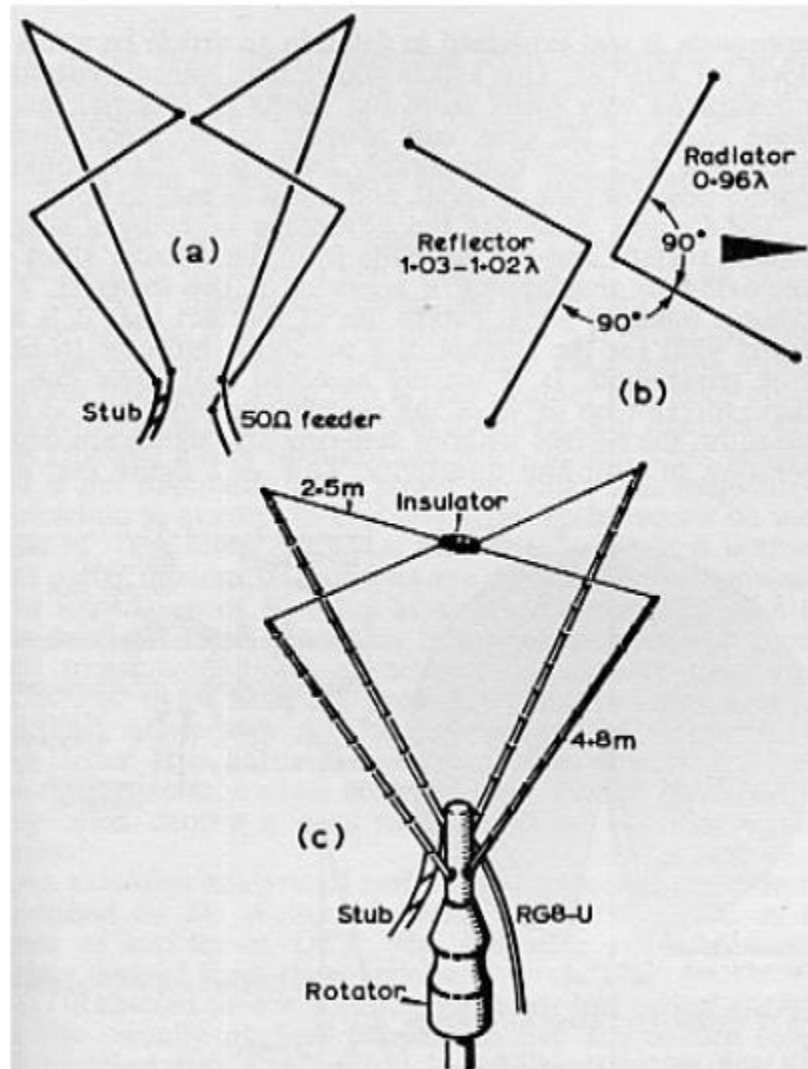

101 - Dual Polarization Antenna for 80m and 40m

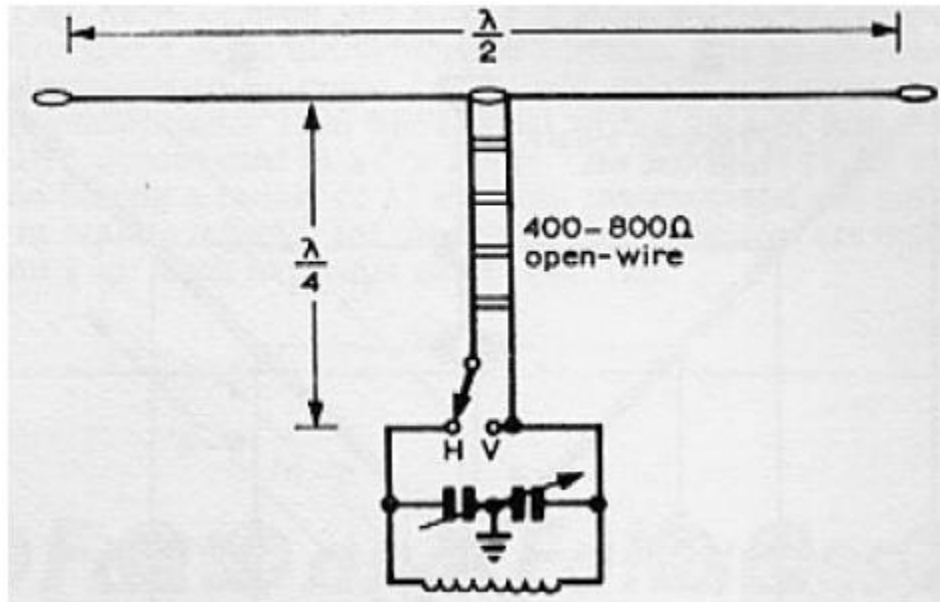

102 - Directive 300-ohm-Ribbon Folded Dipole for 15m

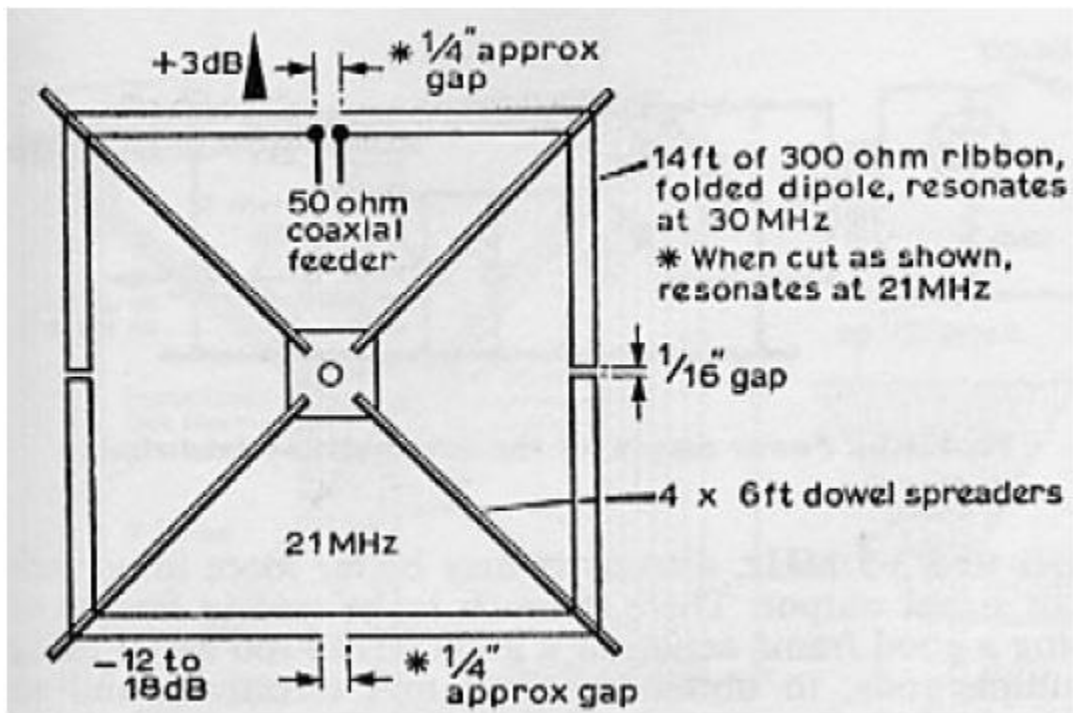

103 - Miniature Directive Antenna for 10m

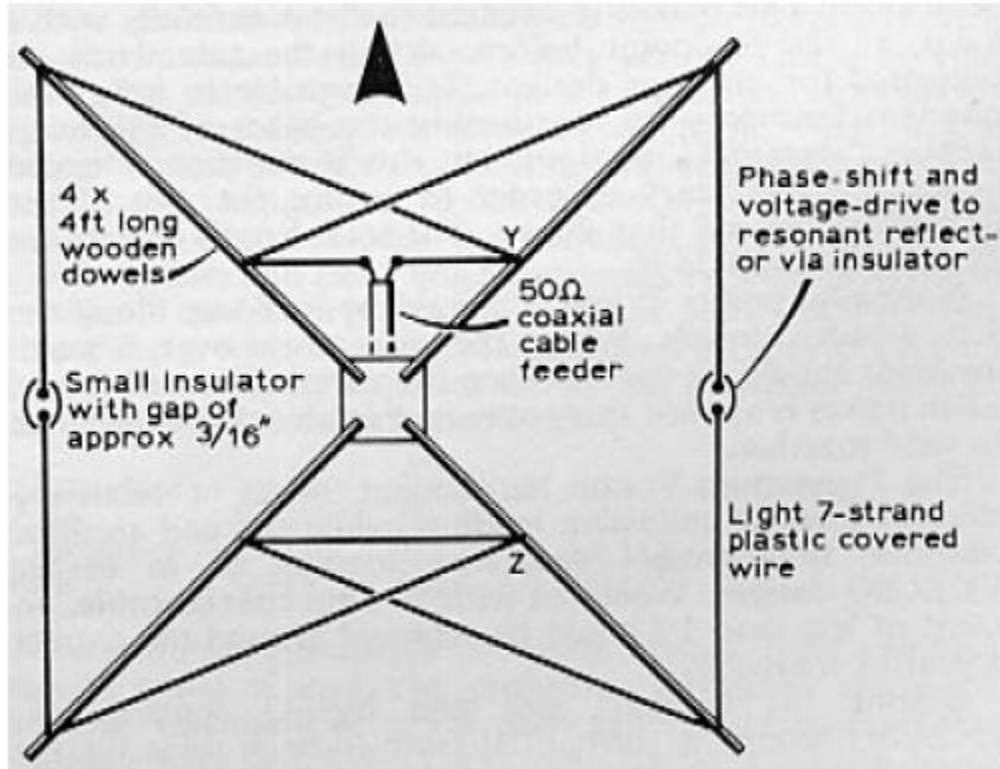

104 - Biquad Antenna 12dBi-Gain for 2.4GHz

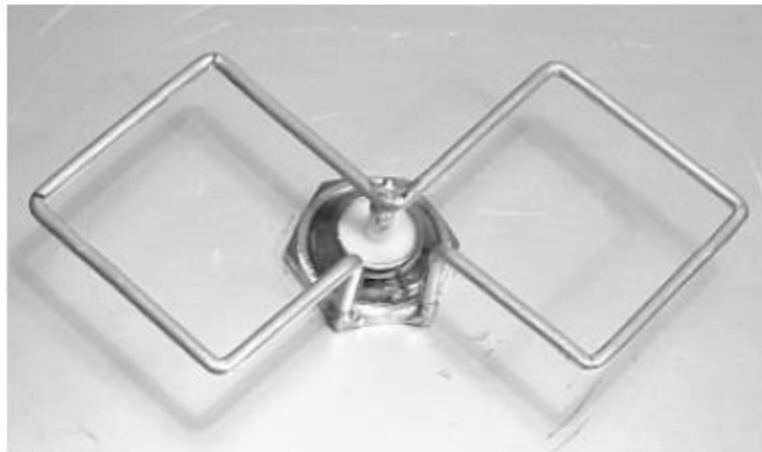
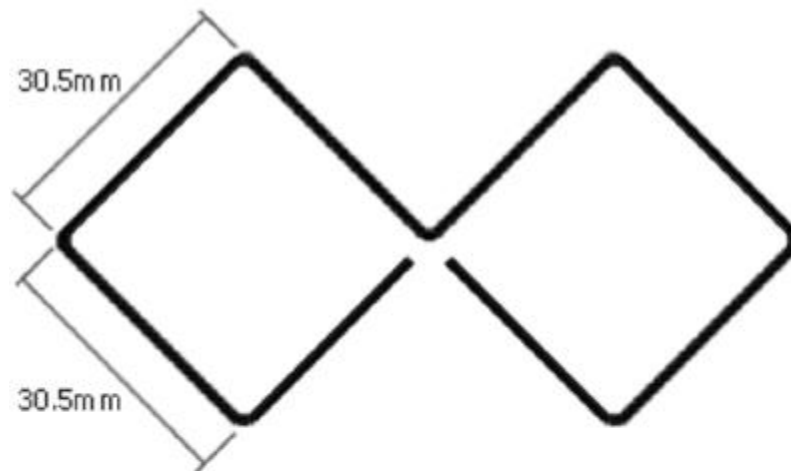

105 - Dual-Rhomboid Antenna for 435MHz to 870MHz

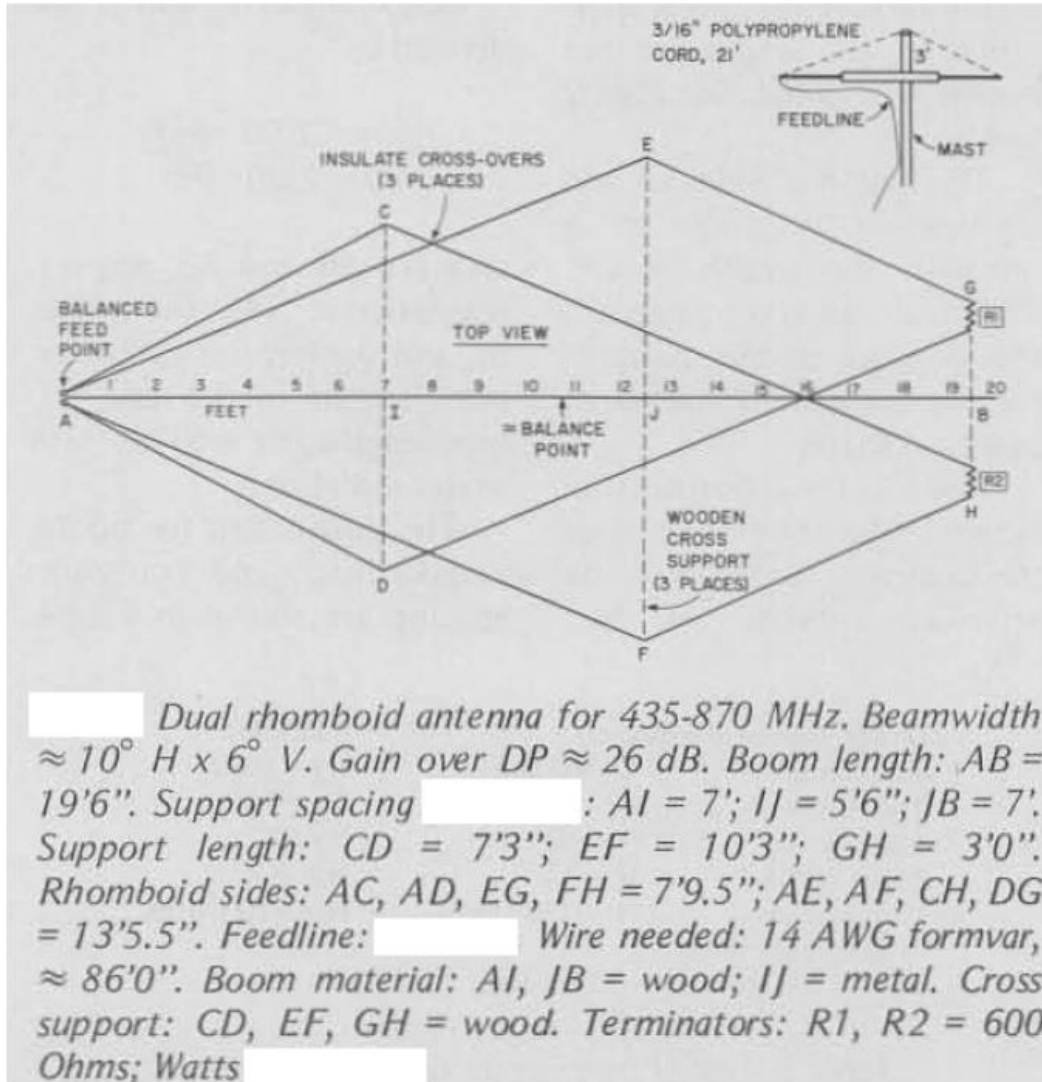

106 - Double-Bazooka Antenna for 80m

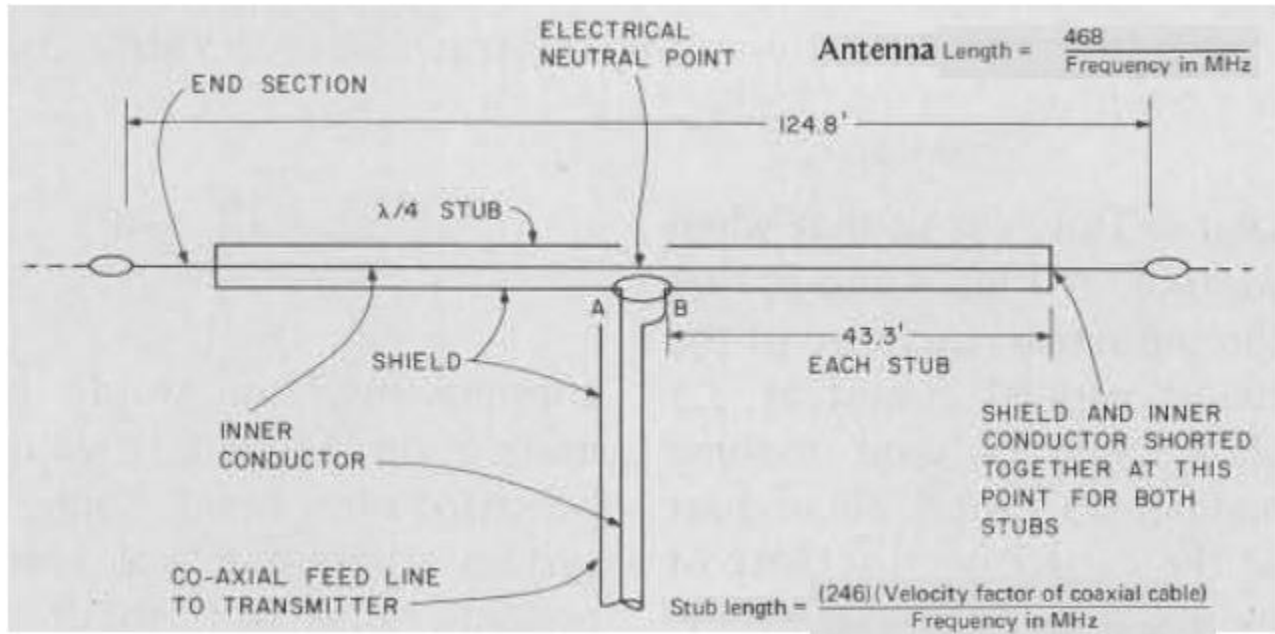

107 - J-Style Antenna

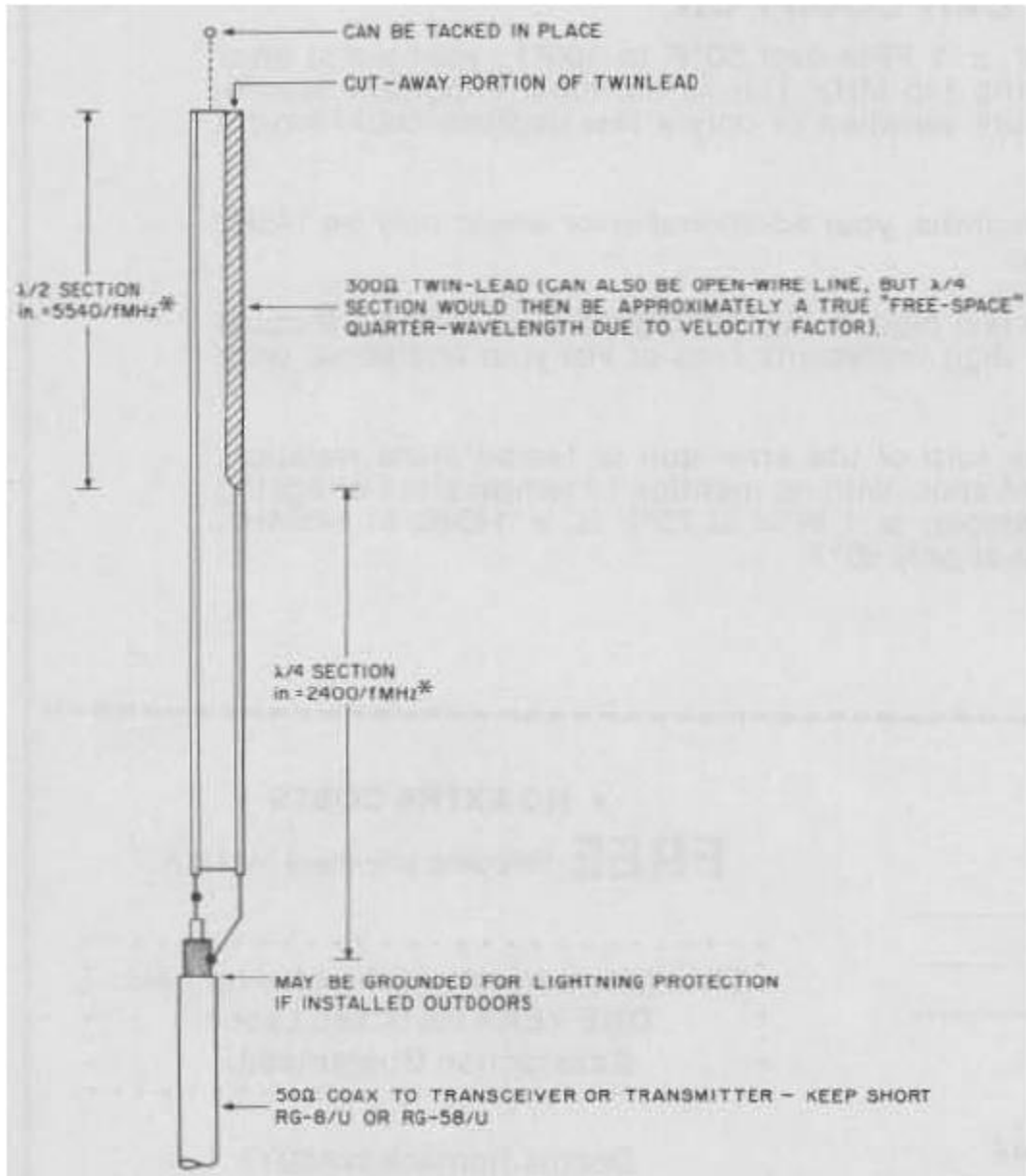

108 - Vertical / Horizontal / Circular Polarization Antenna

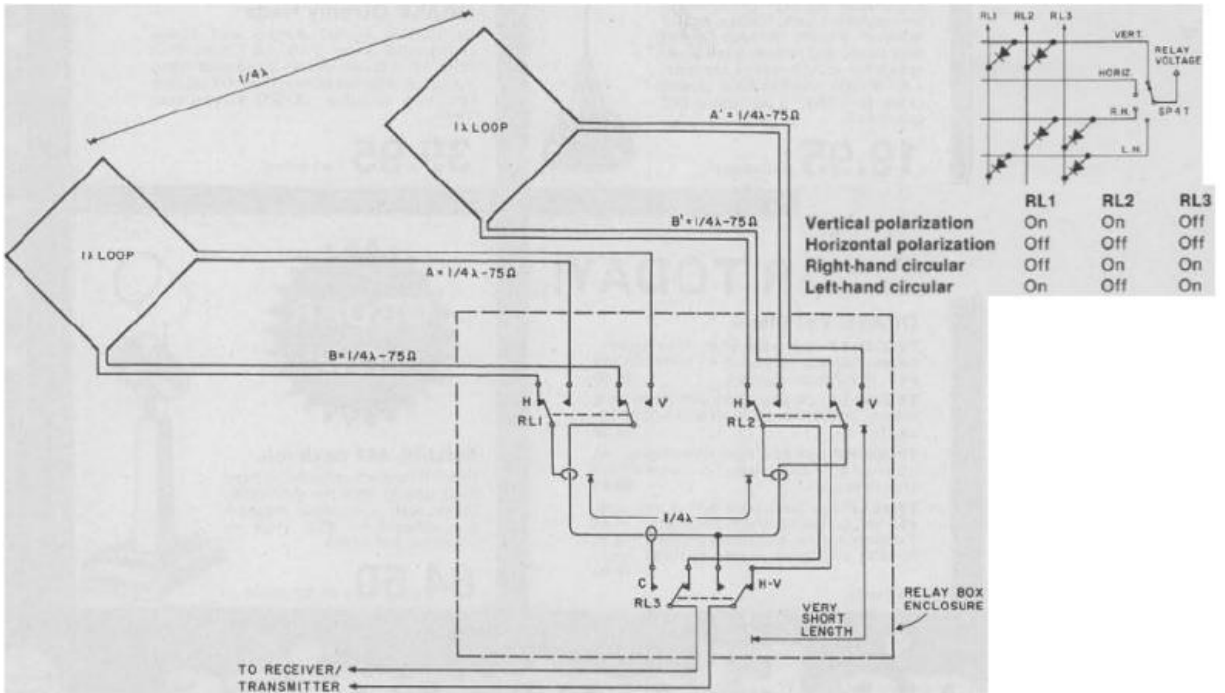

109 - Coax Inverted-L Antenna for 80m

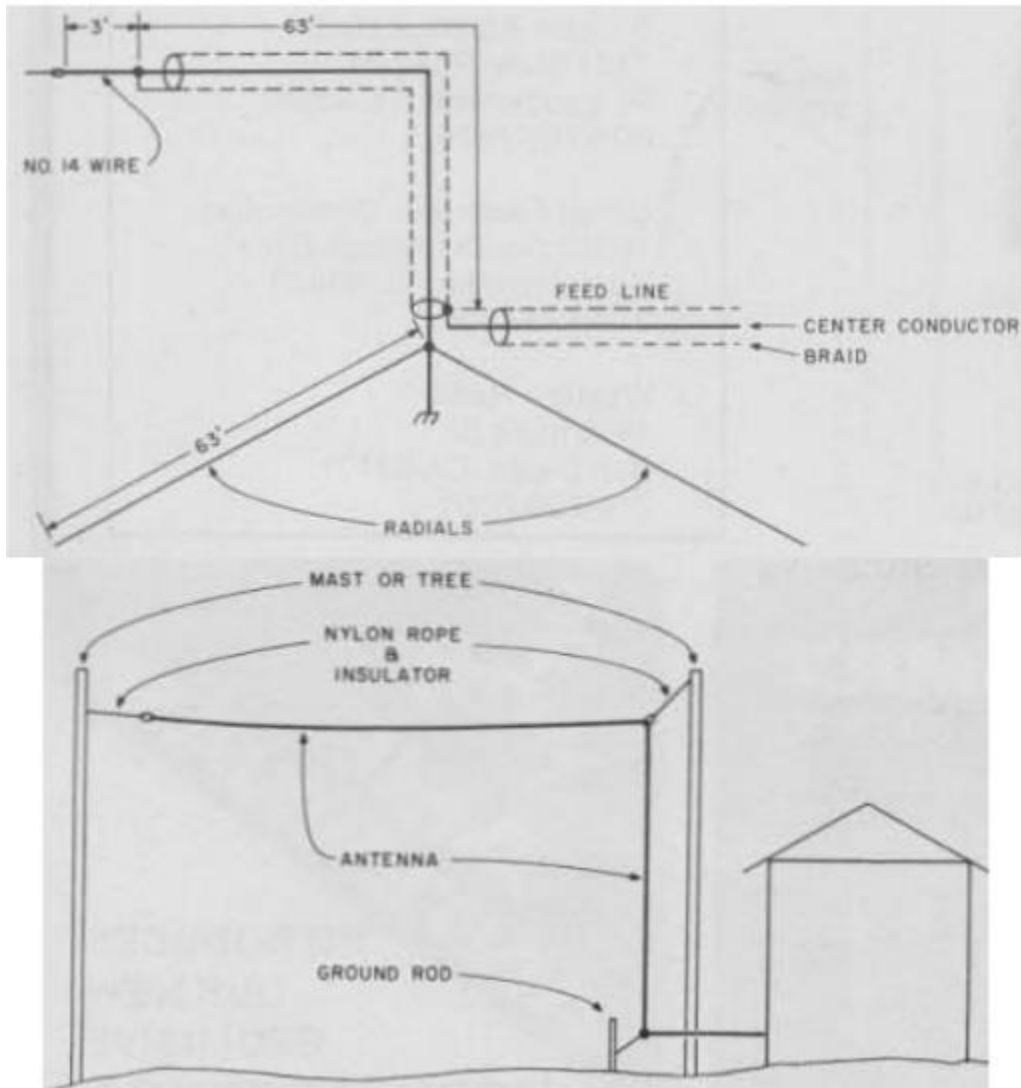

110 - Indoor Compact Loop Antenna for 80m

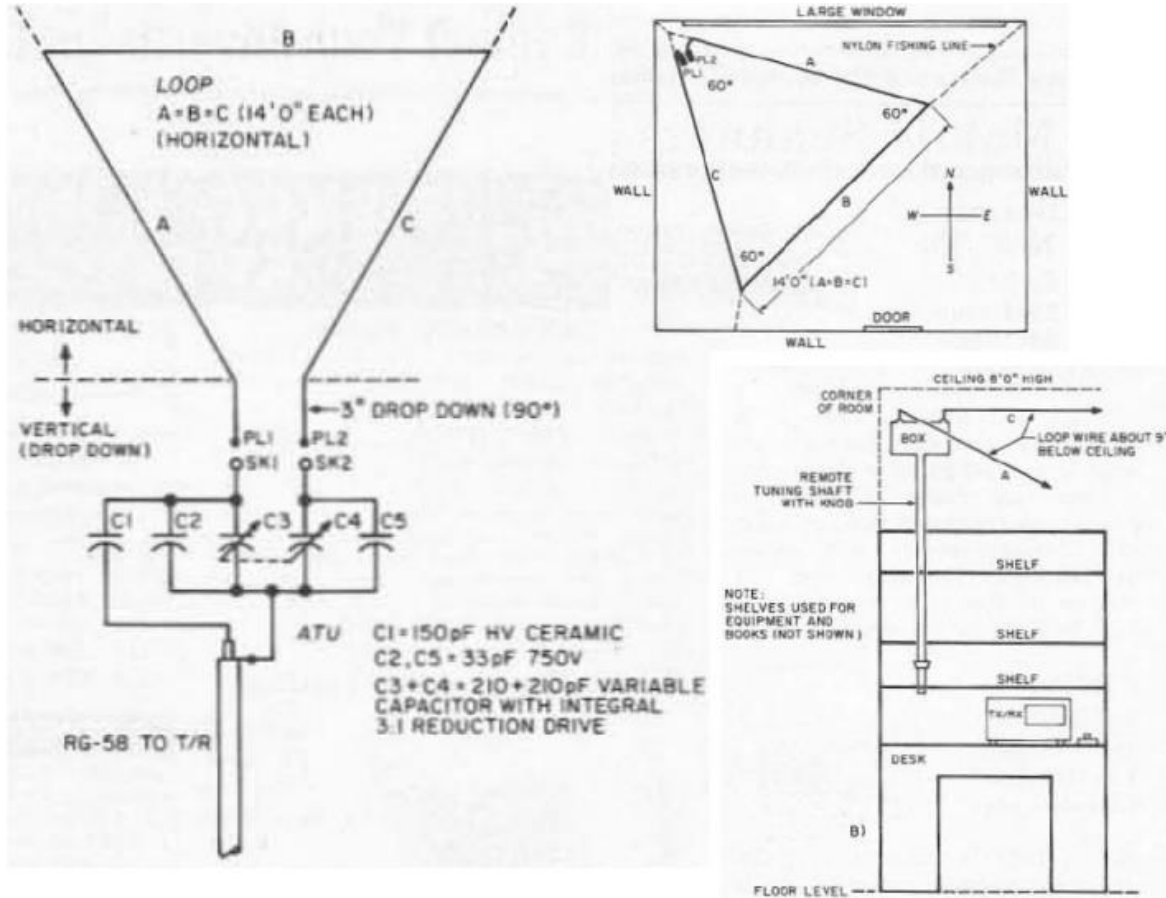

111 - Helix Antenna

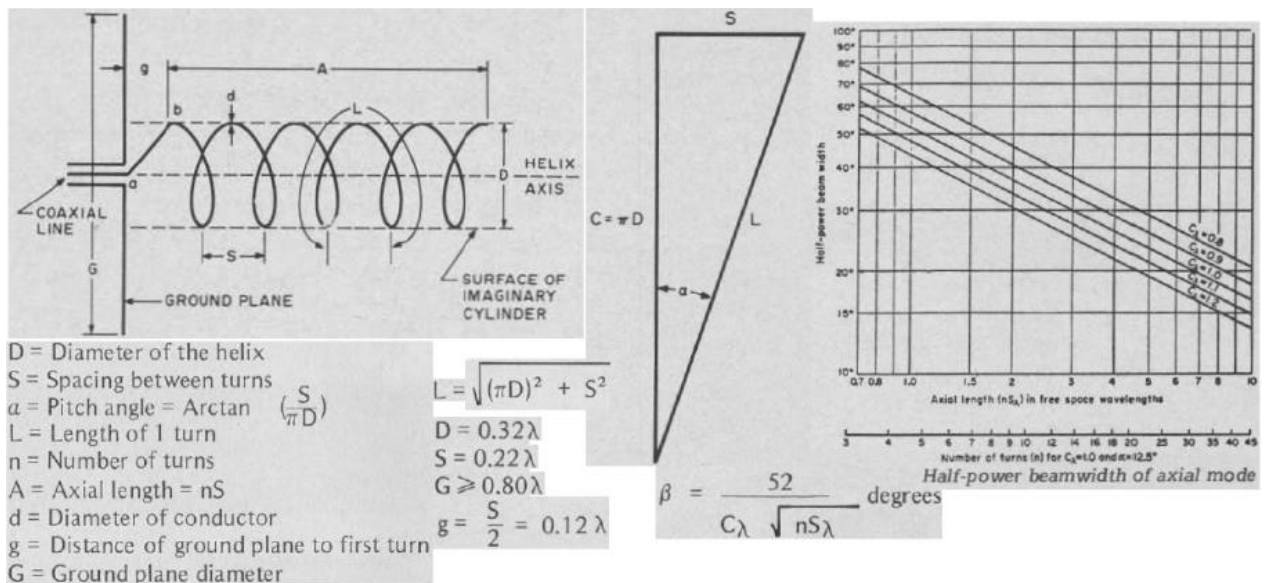

112 - Novice Vertical Antenna for 80m, 40m, 15m, 10m

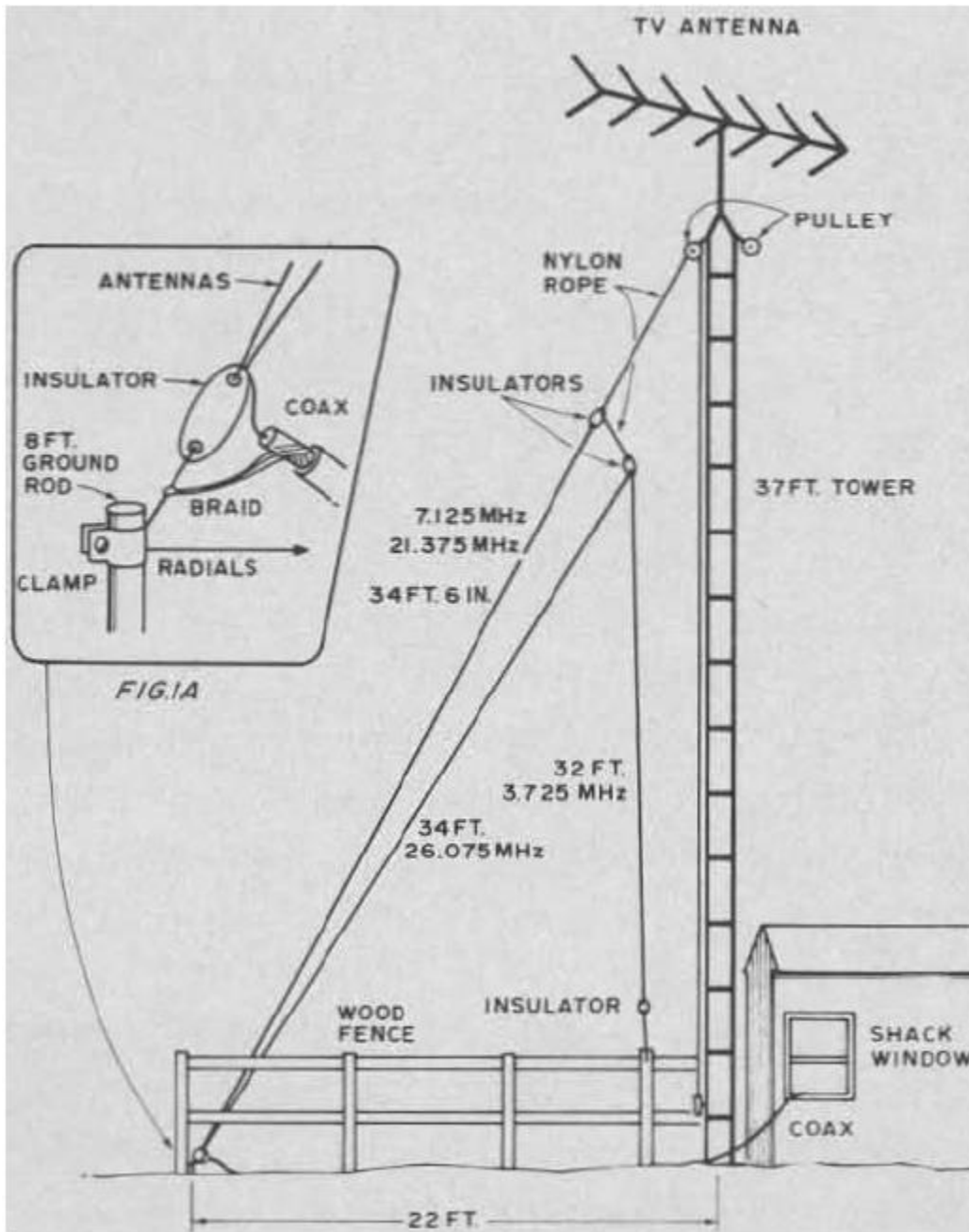

113 - Stub-Loaded Shortened Dipole for 80m

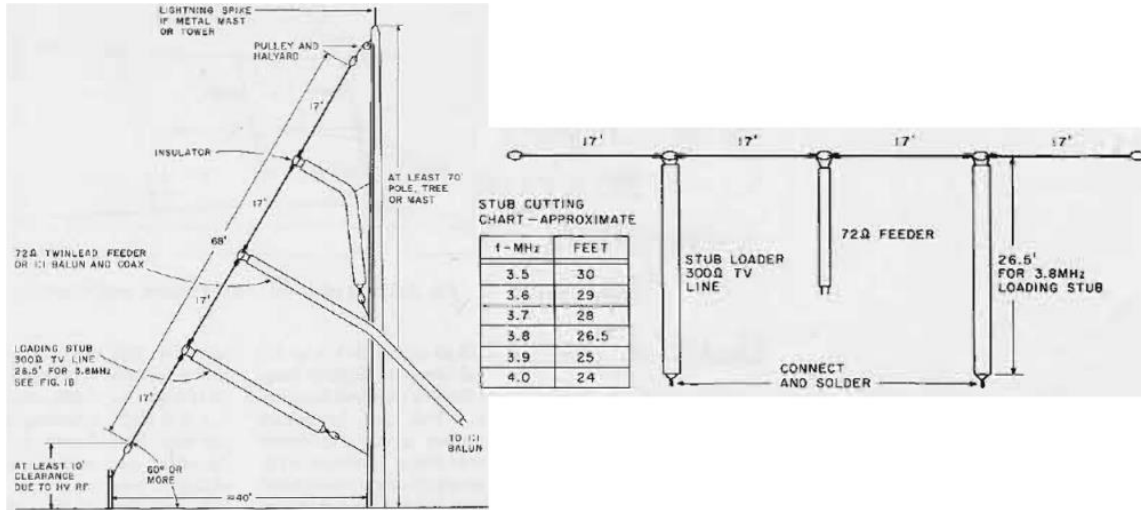

114 - Six-Band Wire-Stub Trap Antenna for 40m-10m

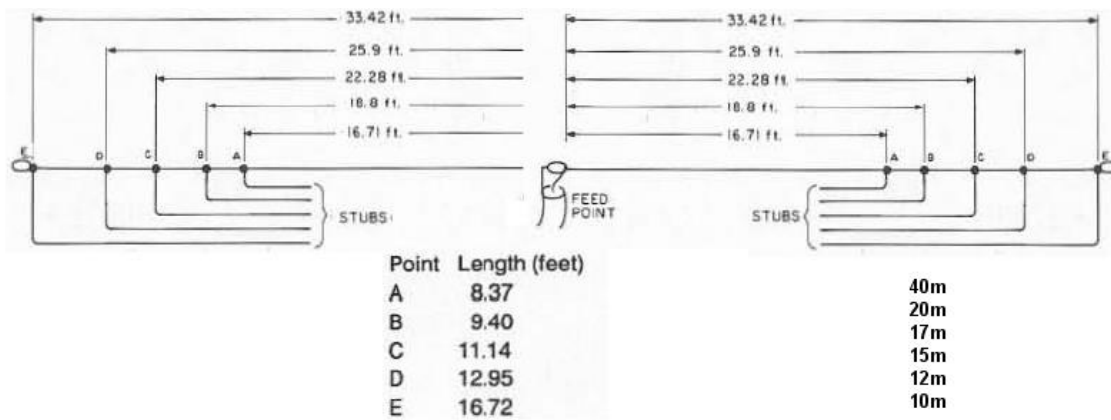

115 - Multiband Half-Wave Delta-Loop Antenna

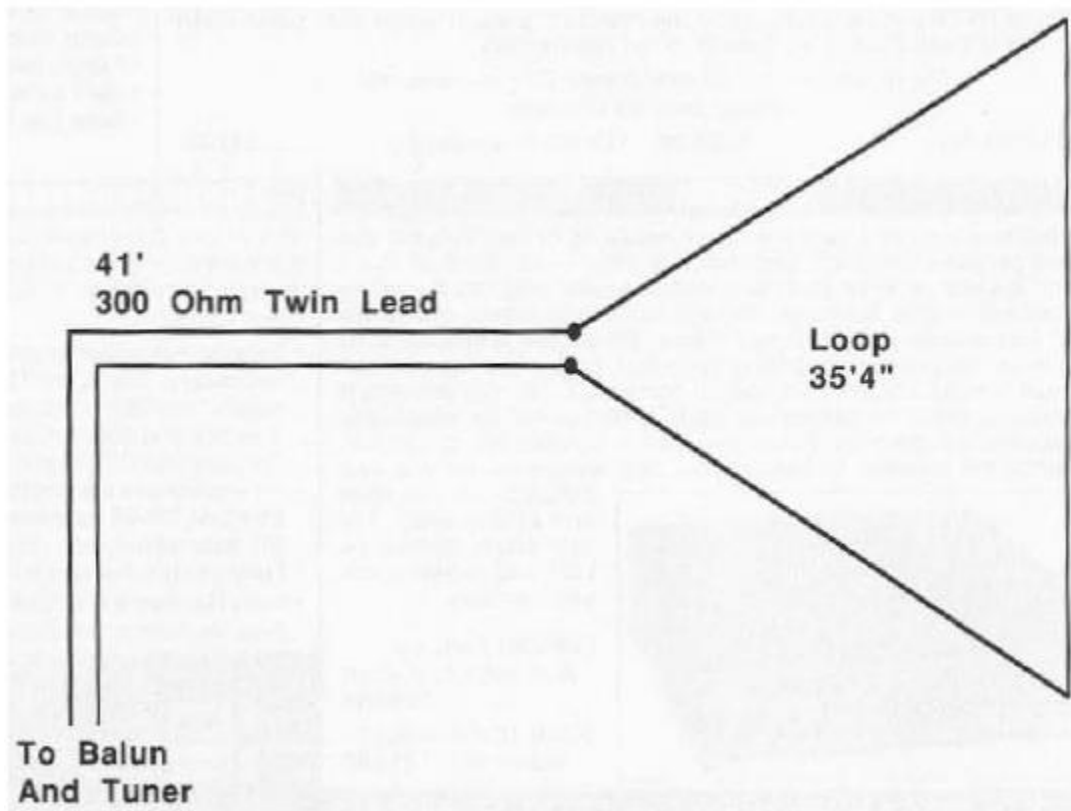

116 - Hybrid Vee for 20m, 17m

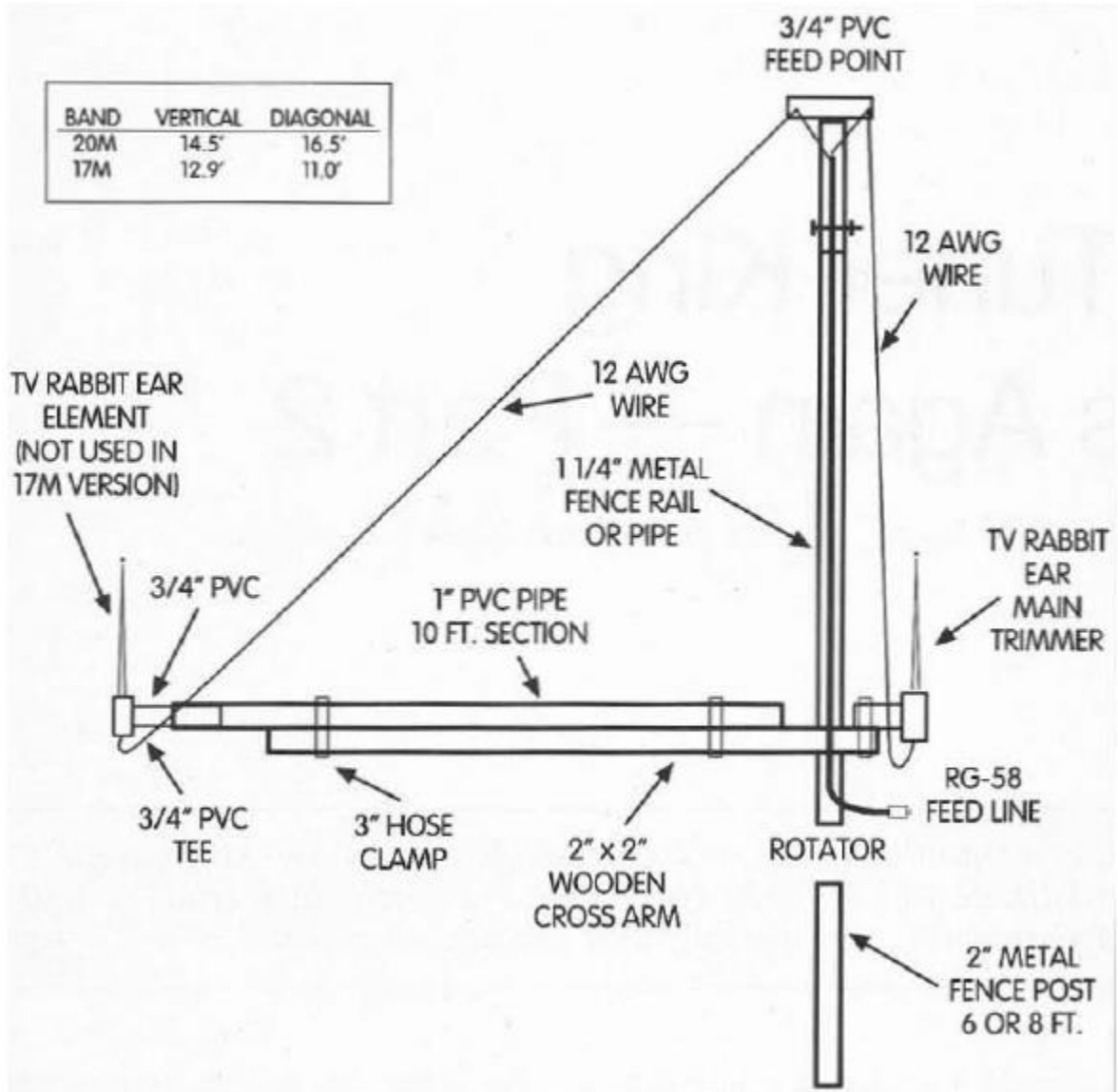

117 - Six-Shooter Array Antenna, Gain=7.5dB

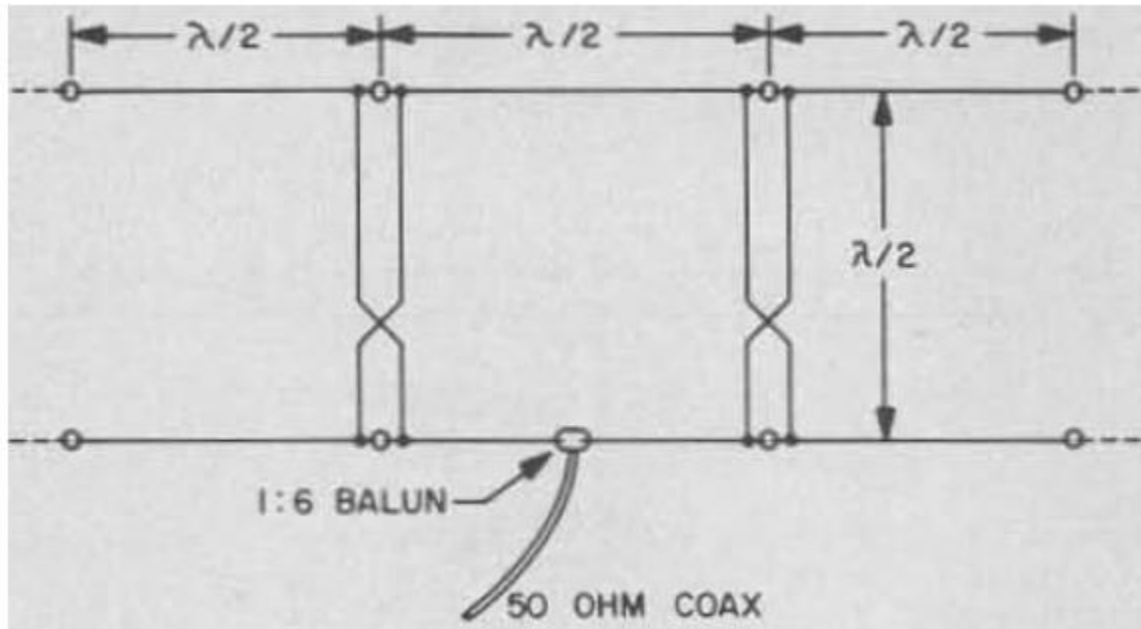

118 - Multiband Ground-Plane Antenna for 10m, 15m, 20m

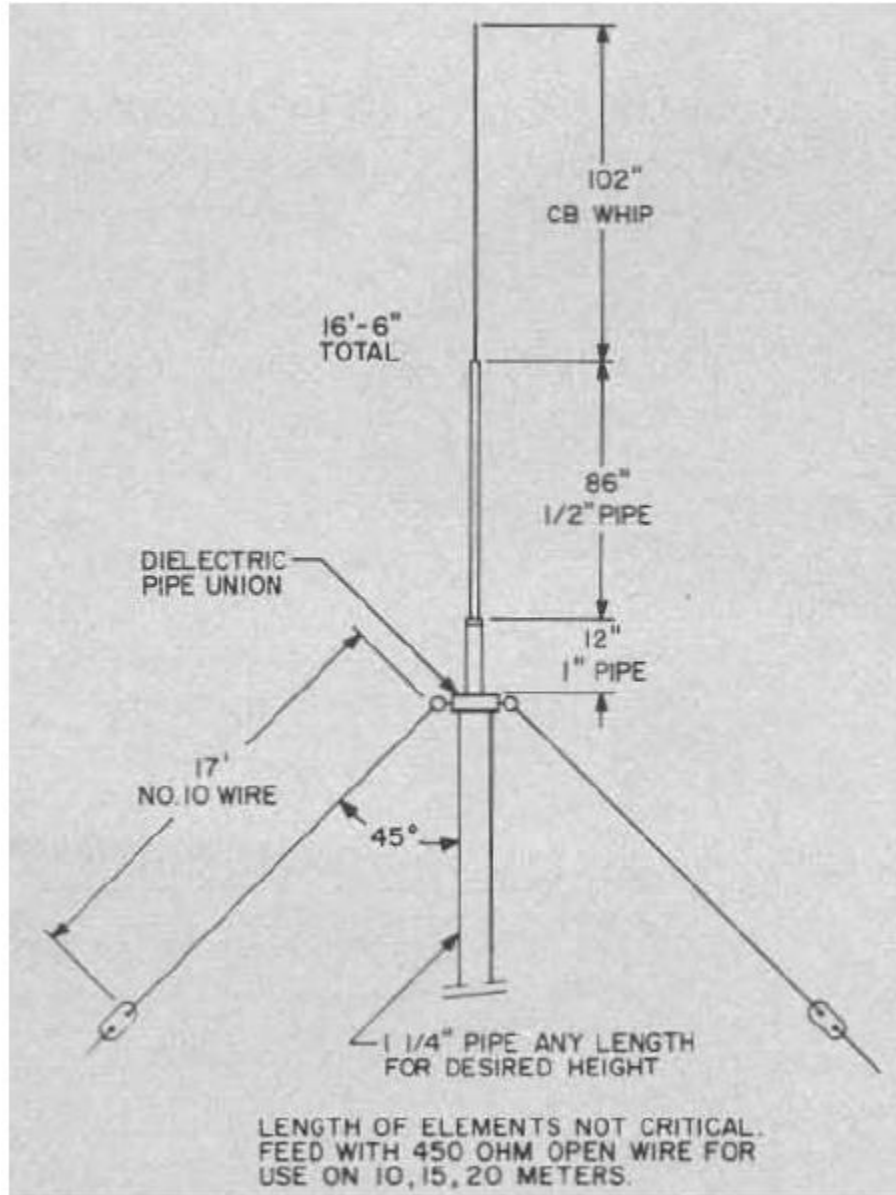

119 - Wire Superbeam Antenna for 10m, 15m, 20m

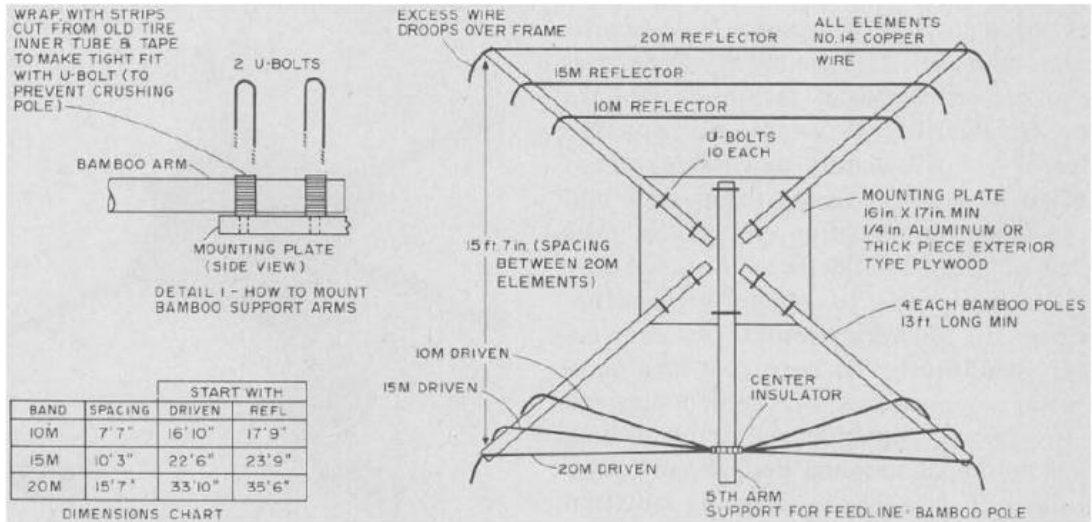

120 - Two Elements Delta-Loop Antenna

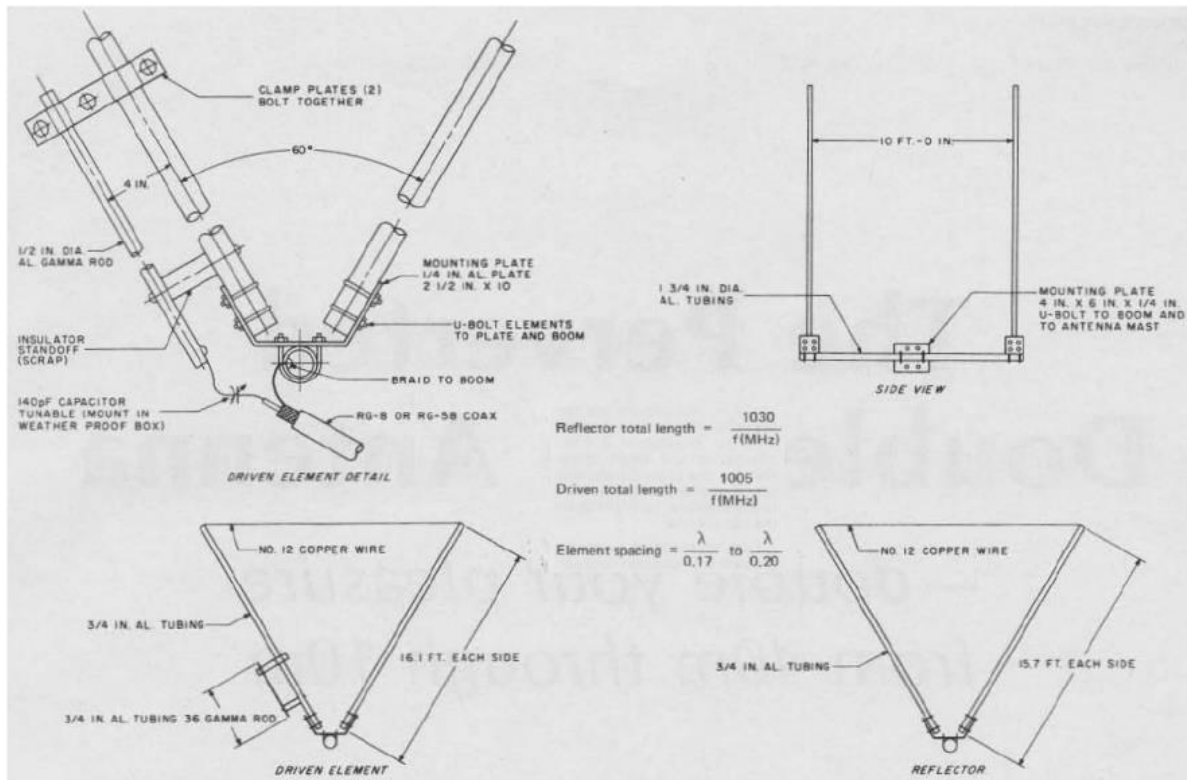

121 - Sterba Curtain Antenna

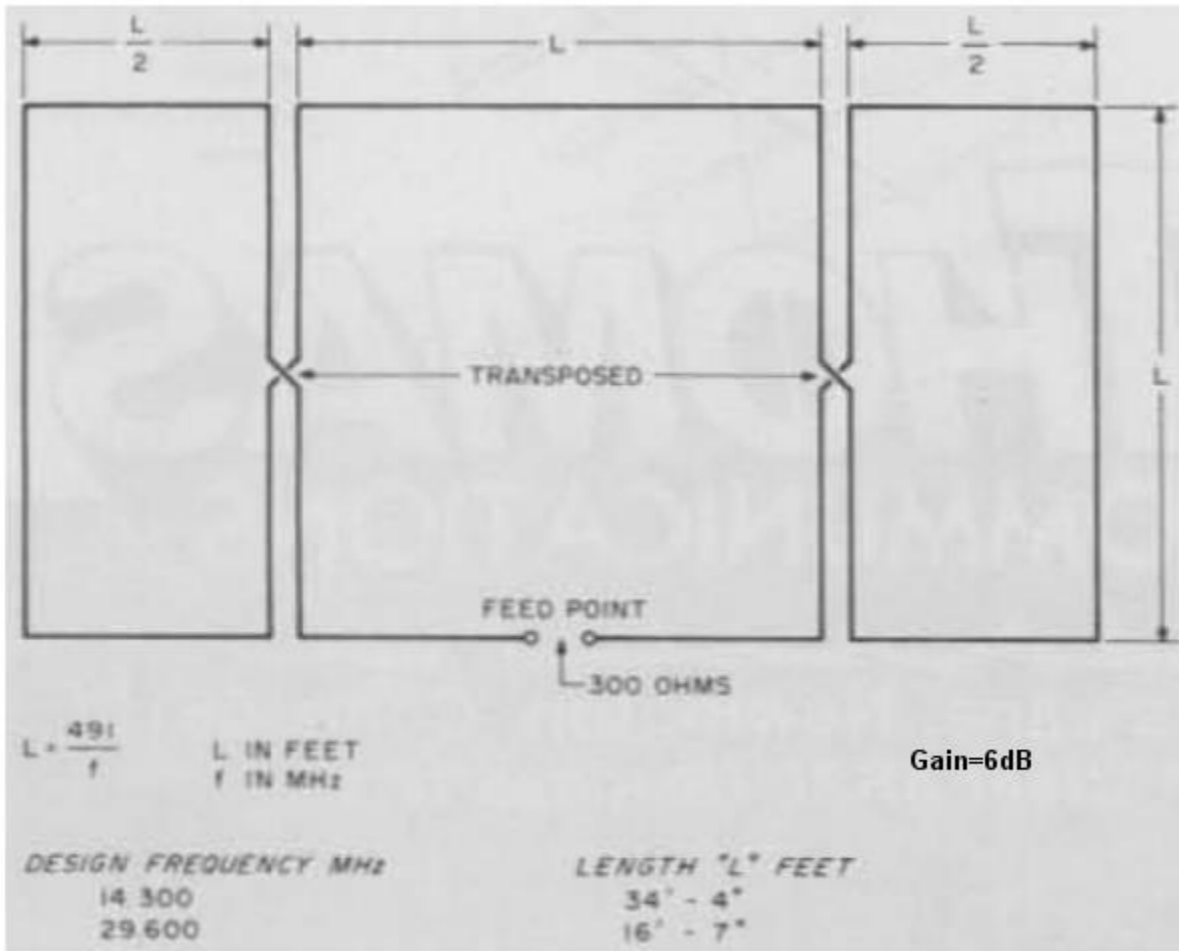

122 - Half-Wave Vertical Zepp Antenna

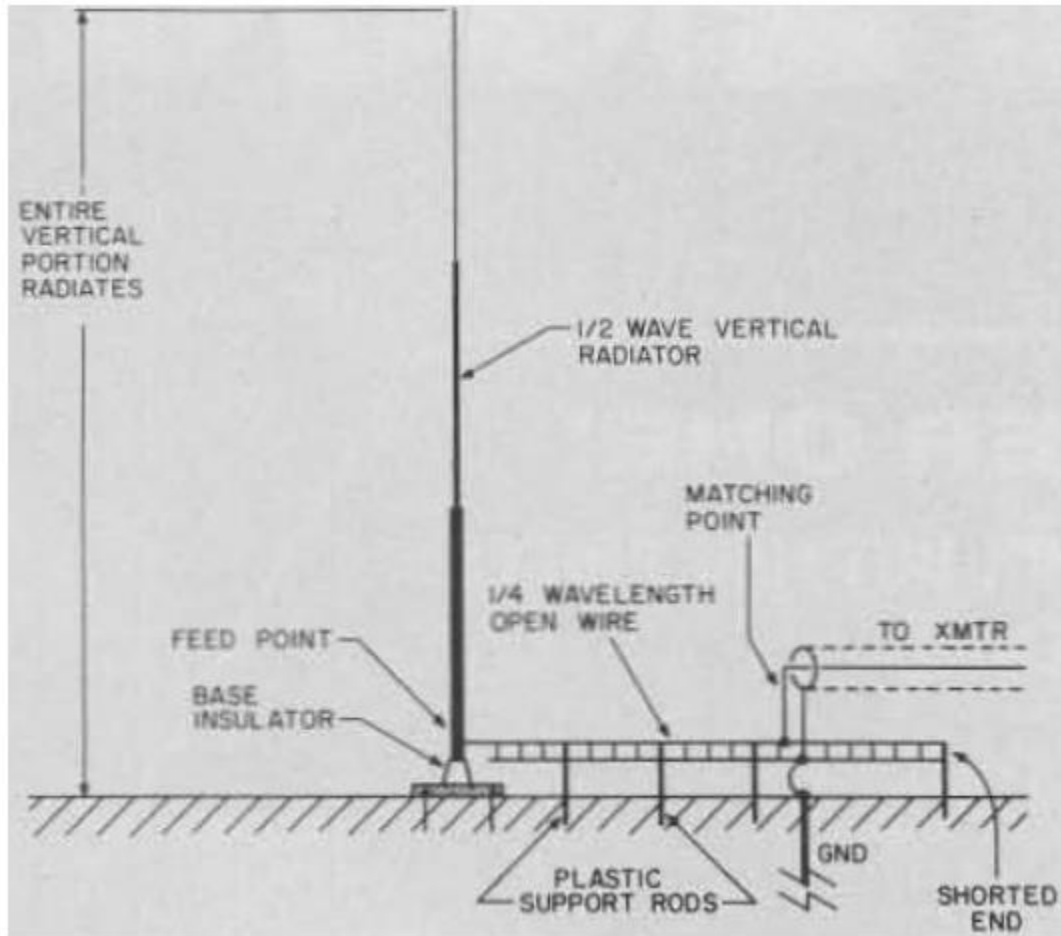

123 - Lazy-Loop Antenna for 40m

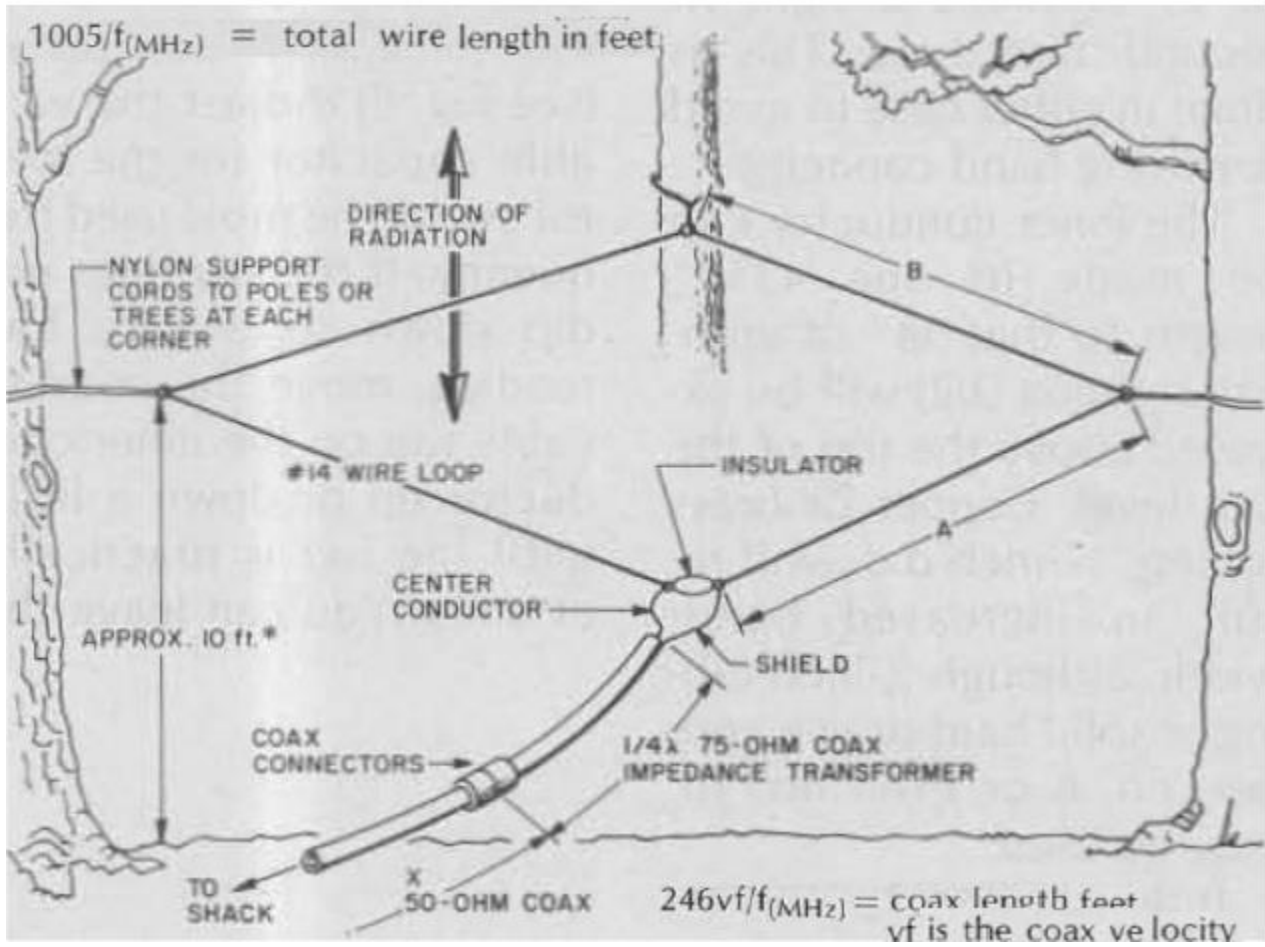

124 - Terminated Folded Dipole for 80m, 40m

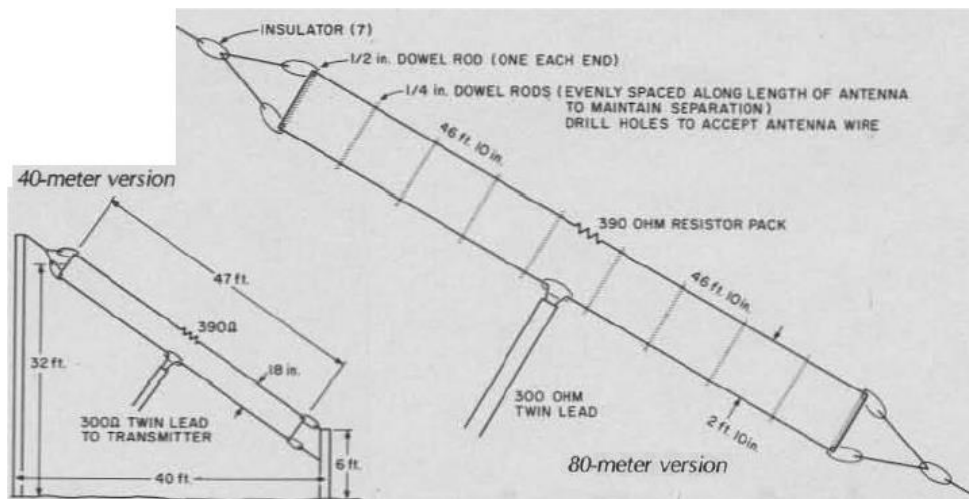

125 - Short-Fat Antenna for 15m

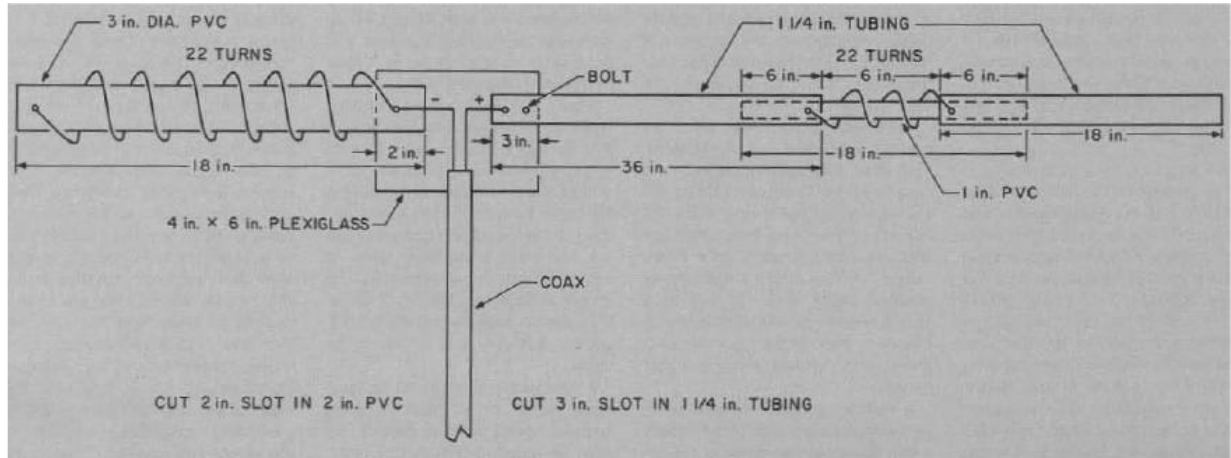

126 - Cobra Antenna for 80m

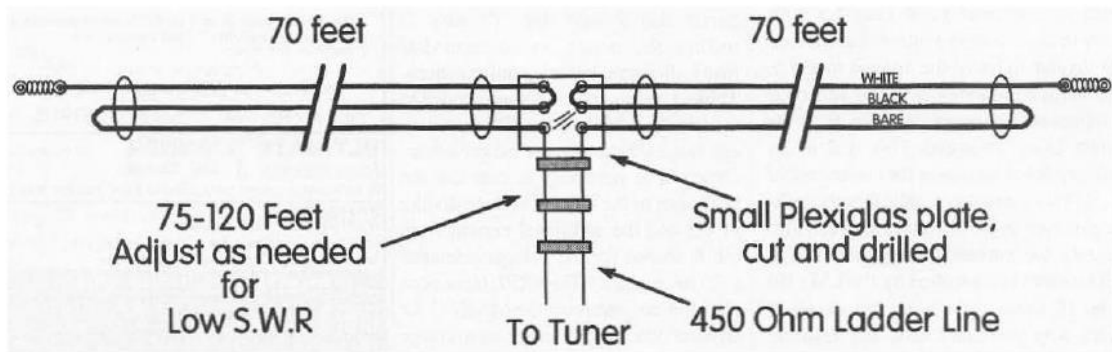

127 - Log-Periodic Wire Antenna for 20m, 15m, 10m

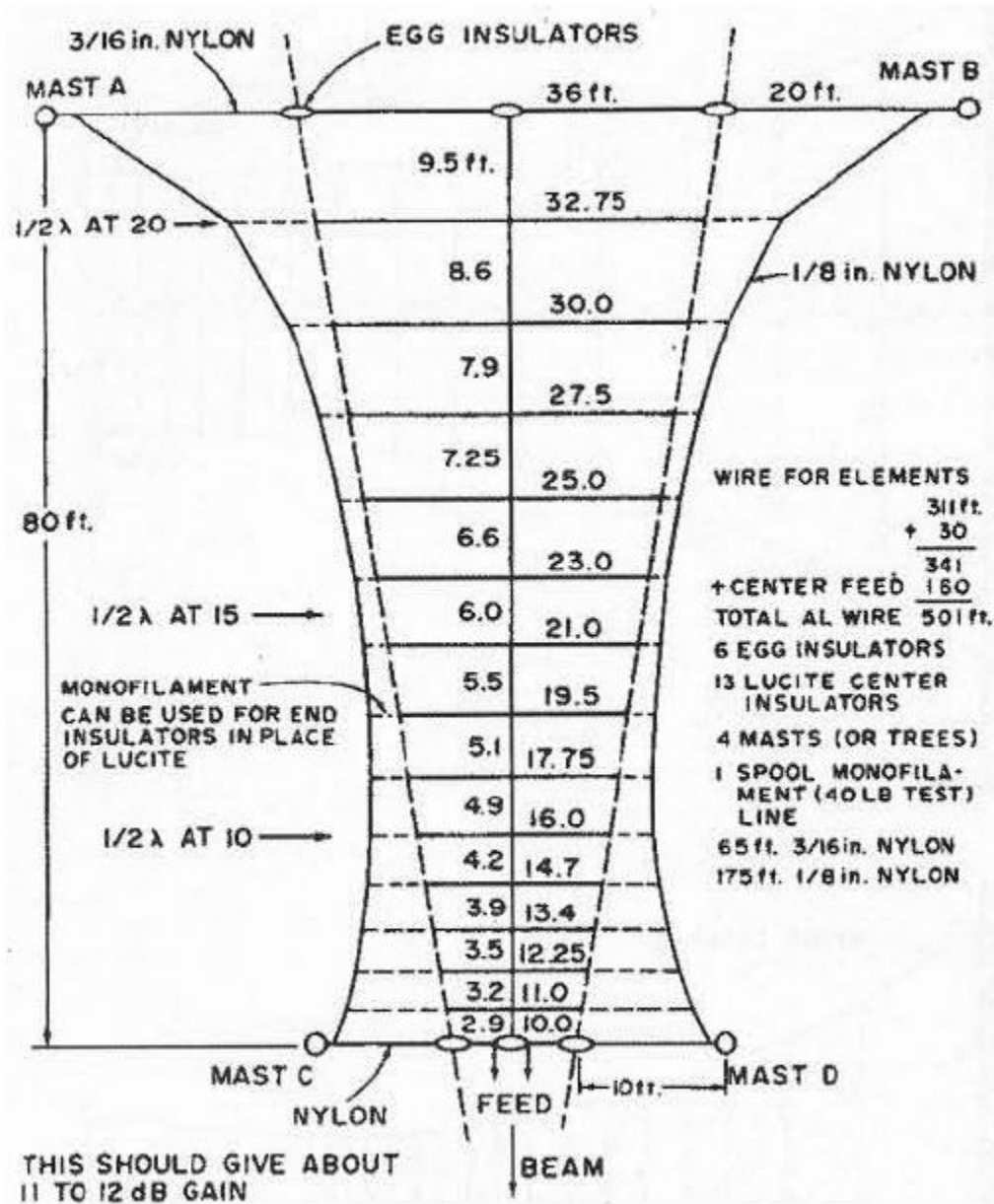

128 - 5-Element Log-Periodic Vertical Antenna for 80m, 40m, 20m

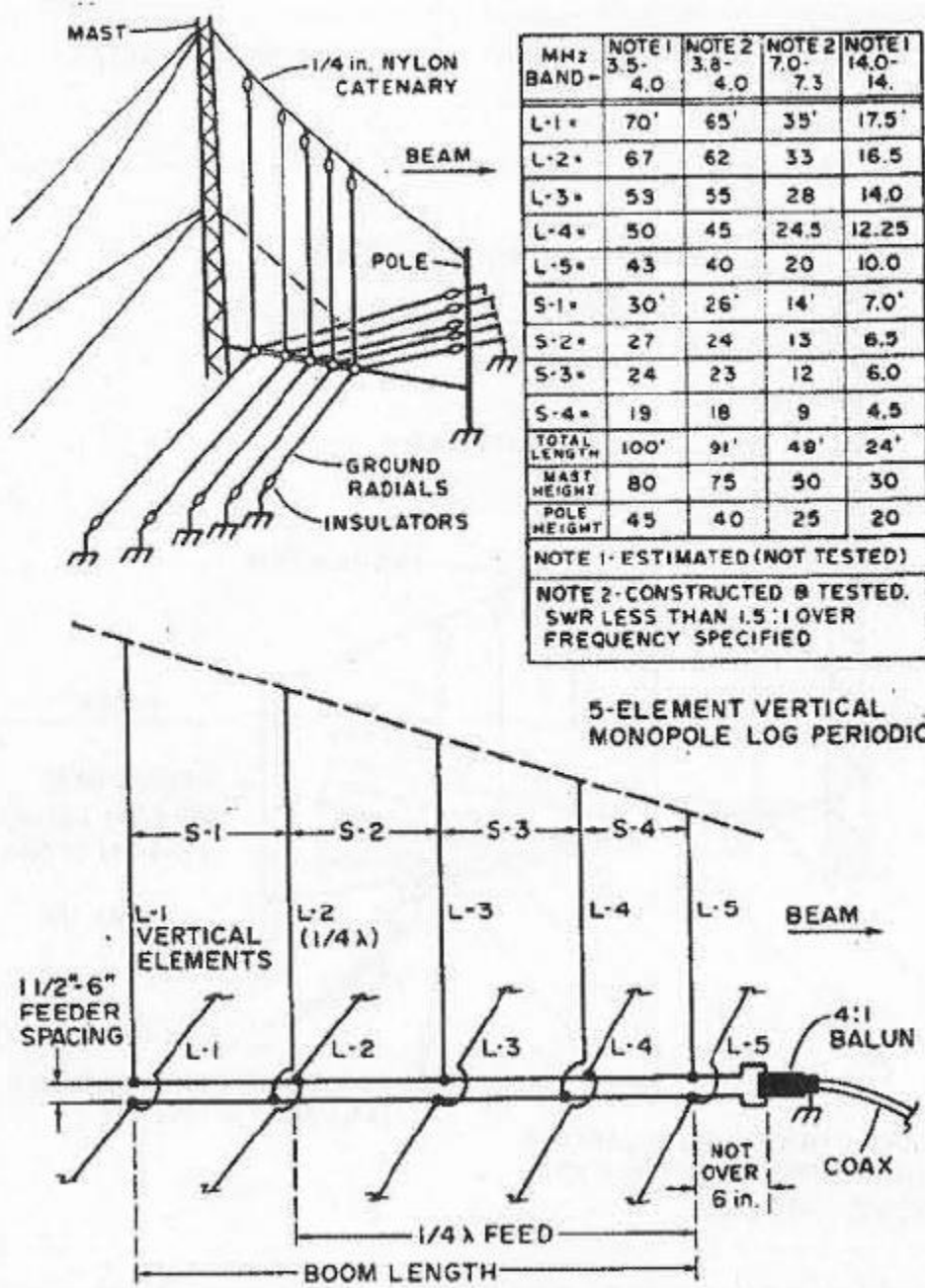

129 - 2m Vertical Wire Antennas

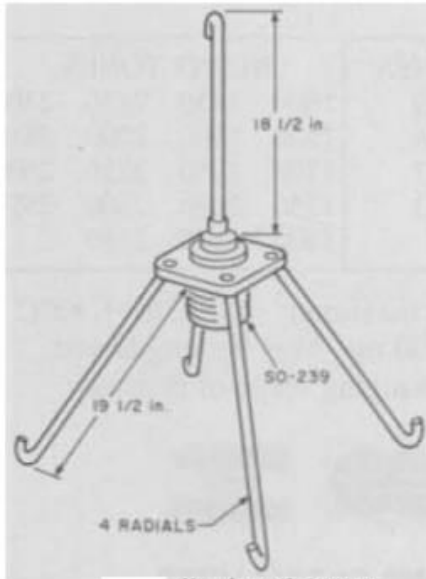

Simple $1/4\lambda$ 2-meter ground-plane antenna.

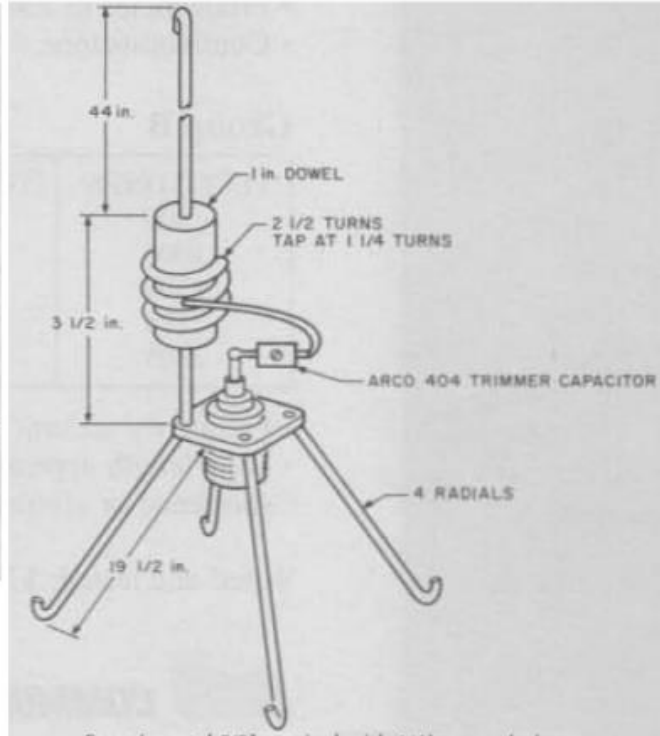

Experimental $5/8\lambda$ vertical with $1/4\lambda$ ground plane.

130 - Earth-Mover Inverted-V Antenna for 40m

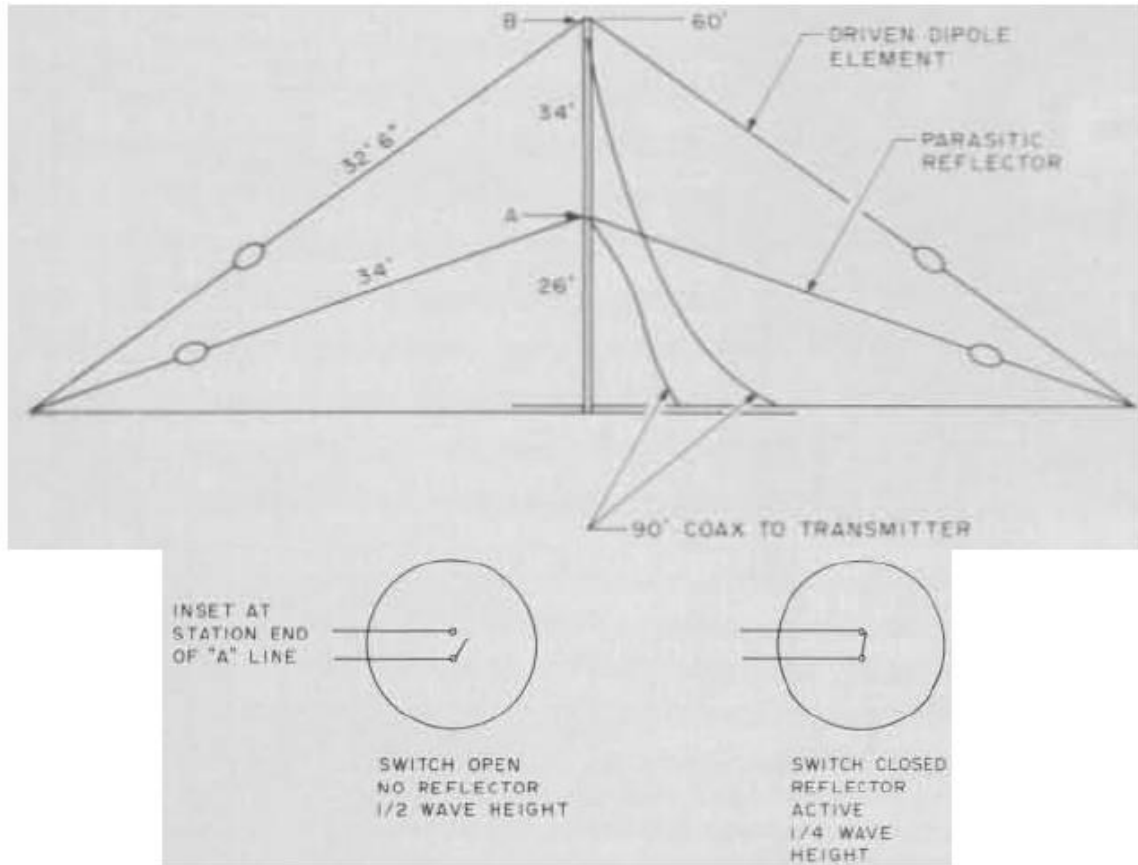

131 - Coax-Cable Collinear Antennas

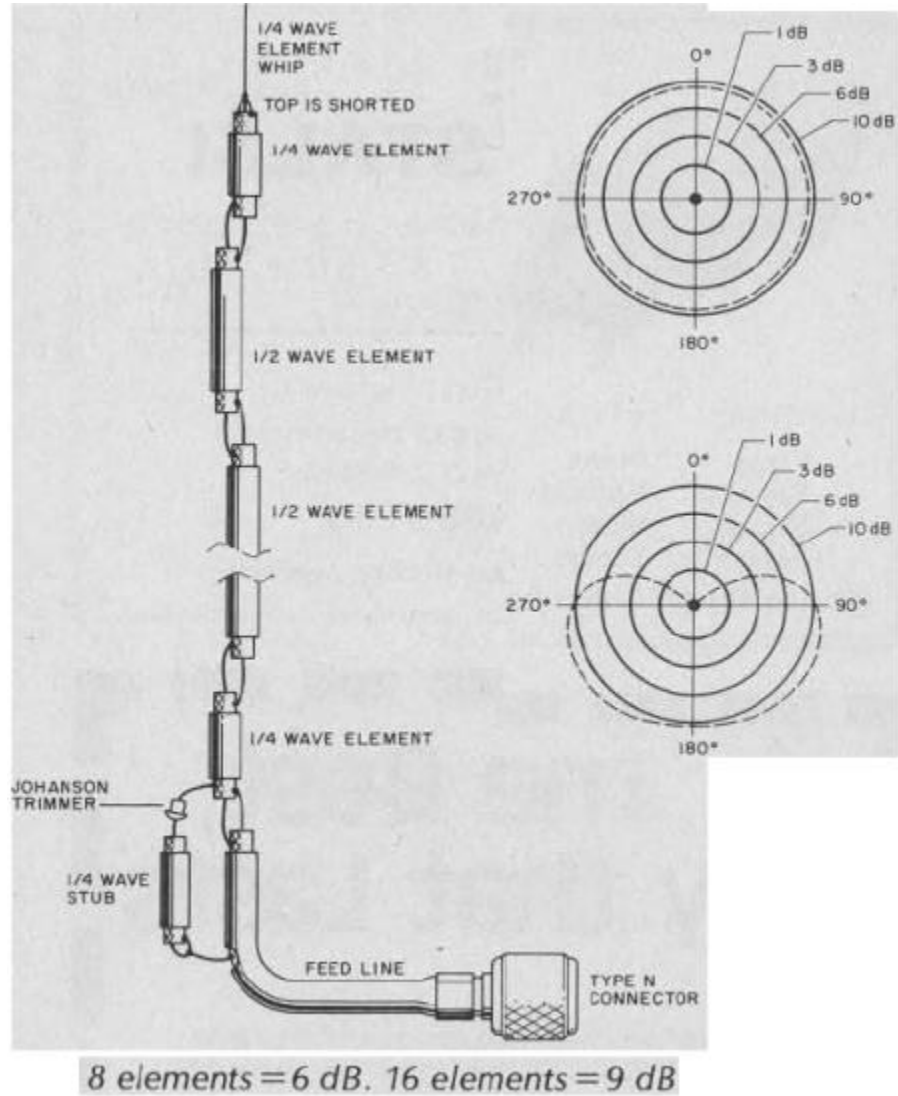

132 - Double Bobtail Antenna for 20m

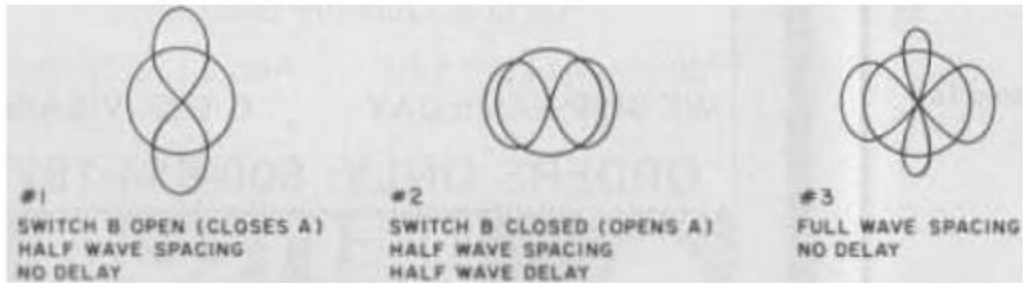
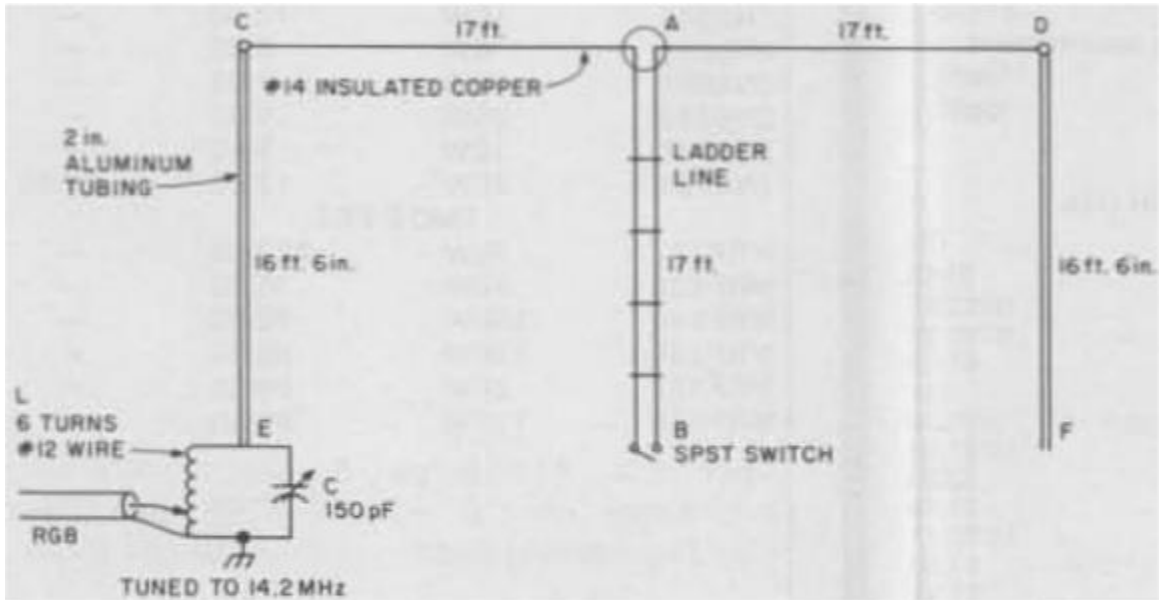

133 - Collinear Zepp Antenna

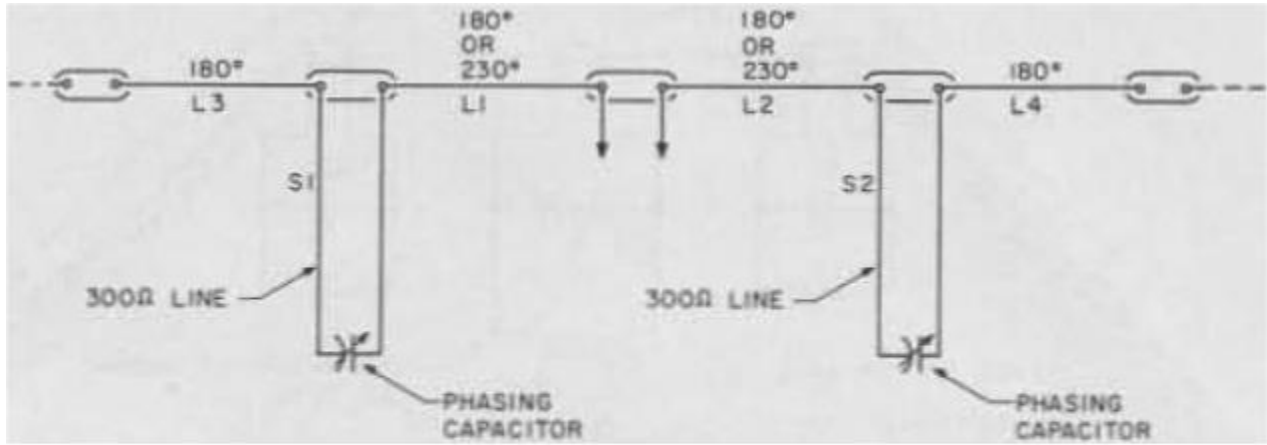

$L1 - L2 = 180^\circ - 468/f$ WHERE $f = \text{MHz}$
 $L1 - L2 = 230^\circ - 600/f$ WHERE $f = \text{MHz}$
 $S1 - S2 = 246 \times 0.82/f$ WHERE $f = \text{MHz}$
 S1-S2 MADE FROM 300Ω TV RIBBON.
 MAKE ABOUT 6 inches LONGER THAN
 CALCULATED VALUES. TRIM IF NECESSARY.

134 - Taylor Vee Antenna for 20m

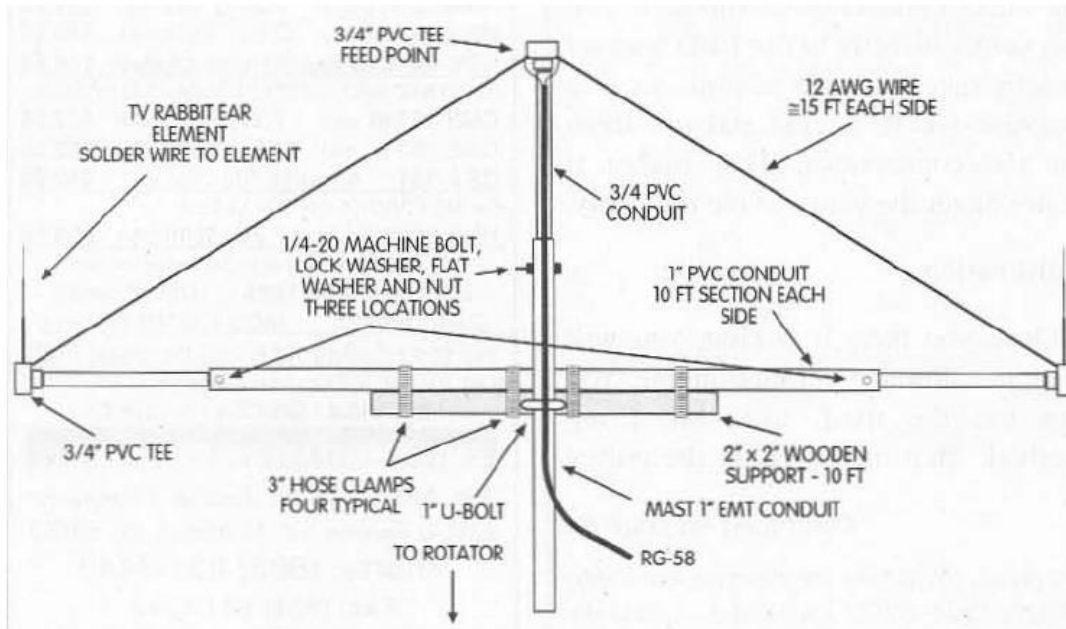

135 - Collinear Vertical Antenna 6dB-Gain for 2m, 1.3m, 73cm

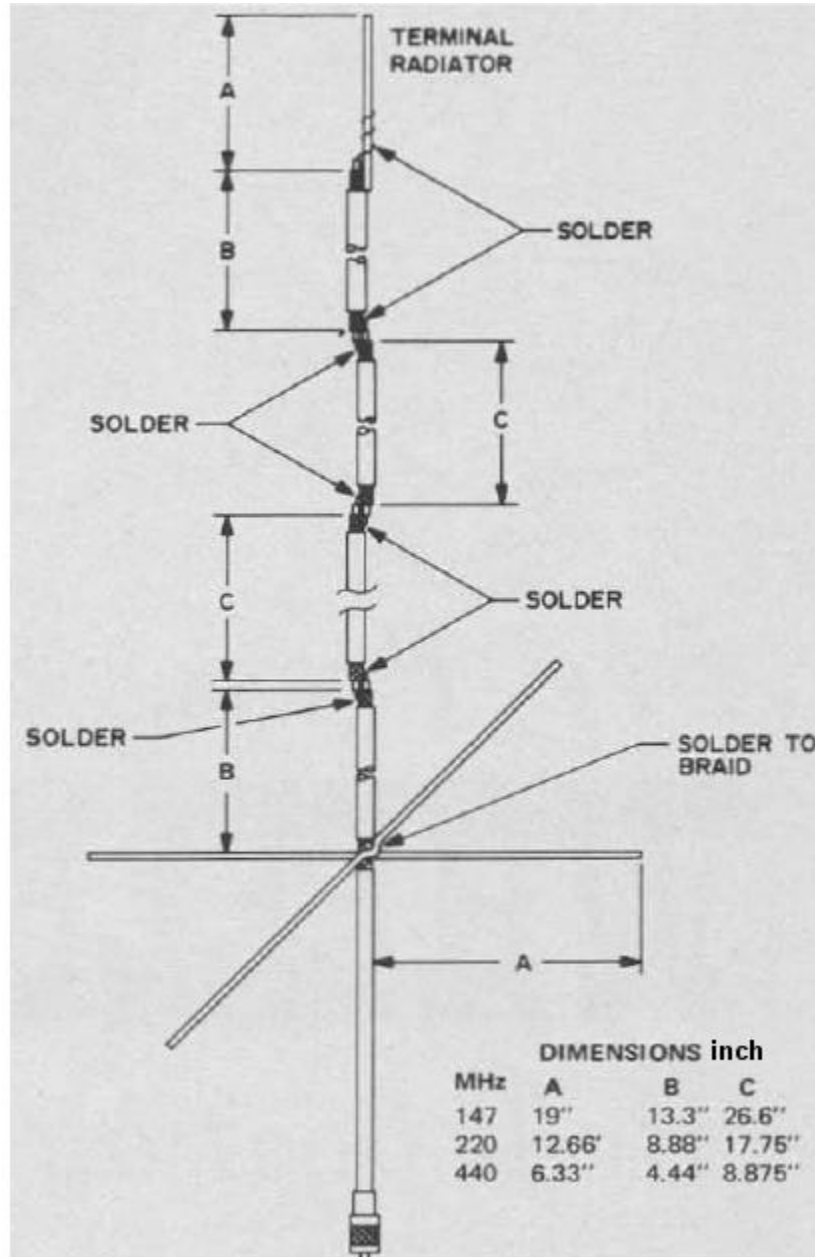

136 - Bi-Loop Antenna for 20m

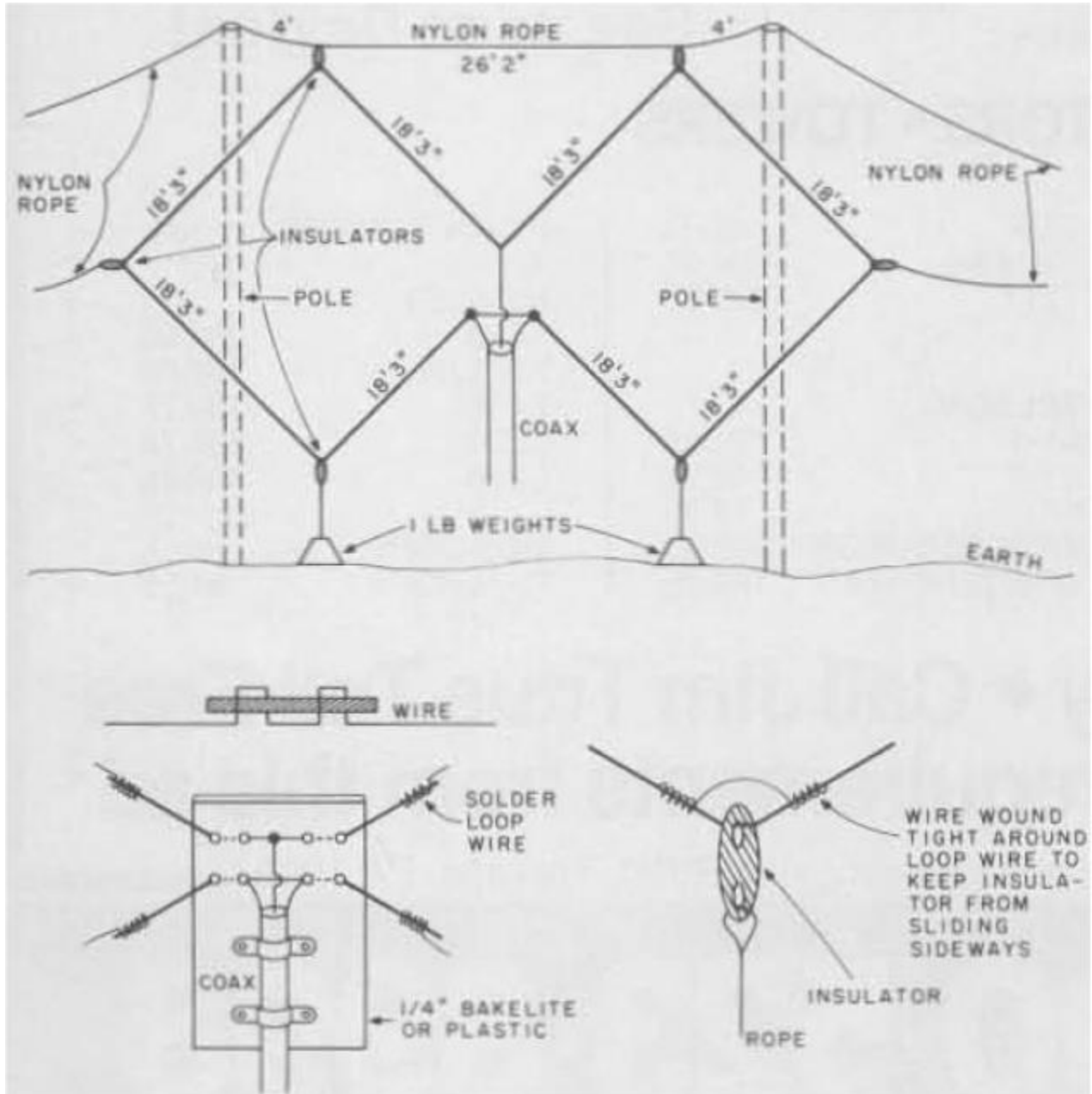

137 - Wire Beam 6dBd-Gain for 10m

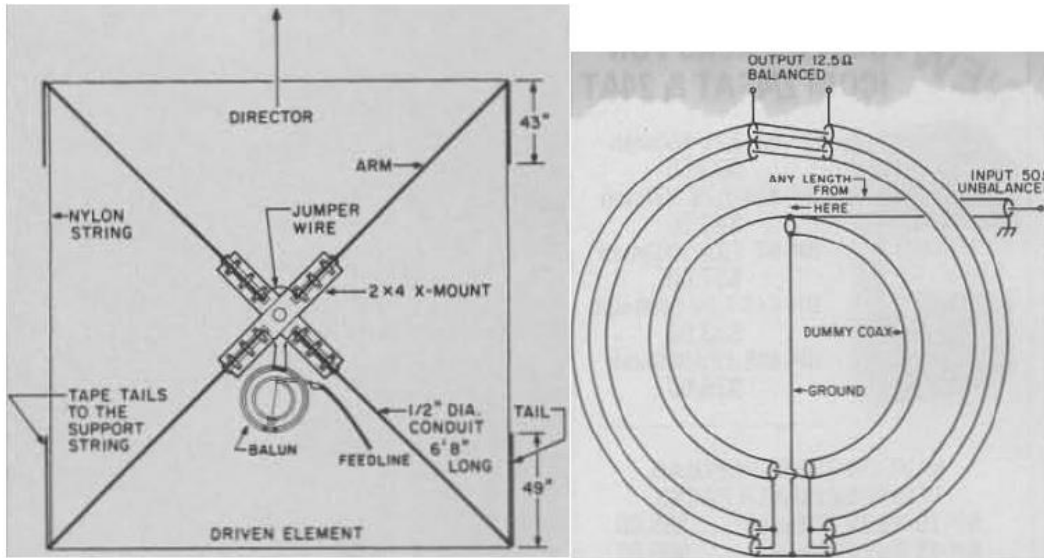

138 - Sloping Diamond Antenna 4dB-Gain for 40m

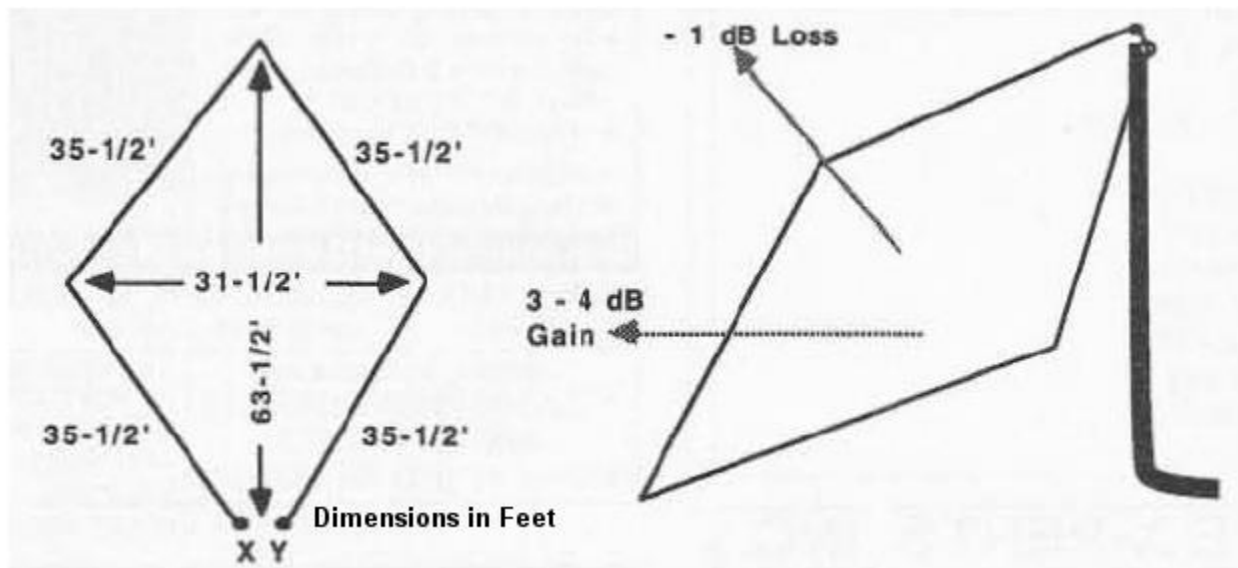

139 - Twisted Loop Antenna for 160m

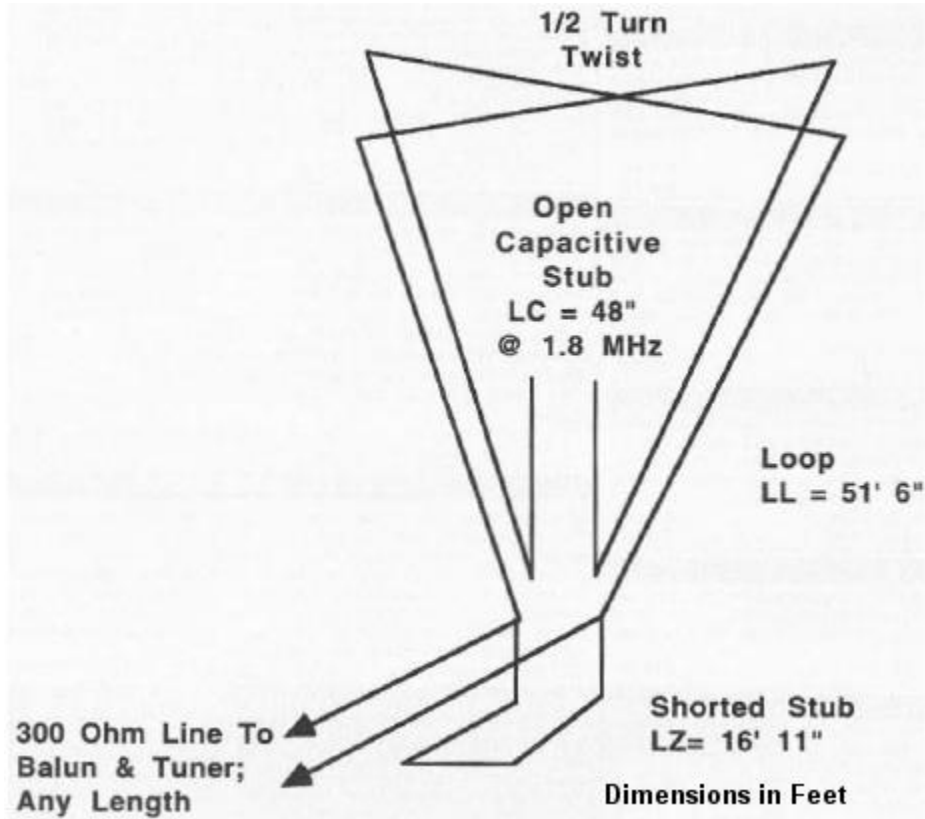

140 - DX RX Loop Antenna for 160m

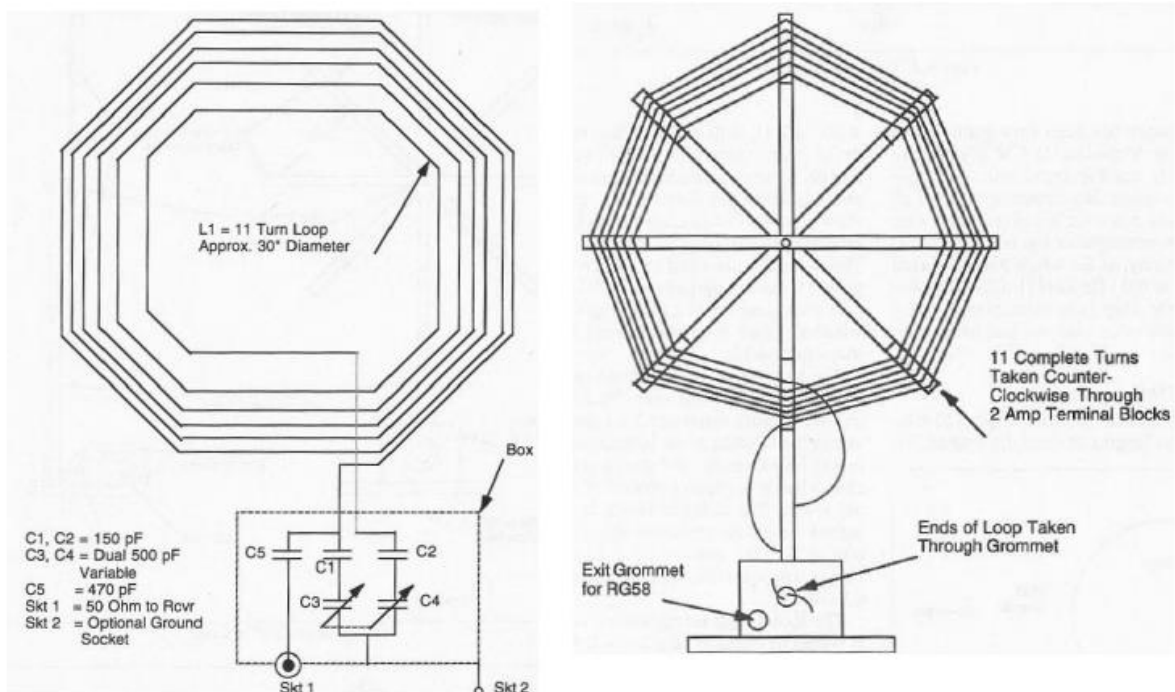

141 - Hentenna 3dB-Gain for 10m, 6m, 2m

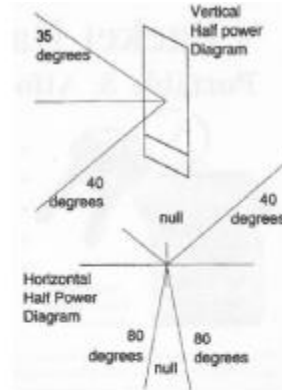
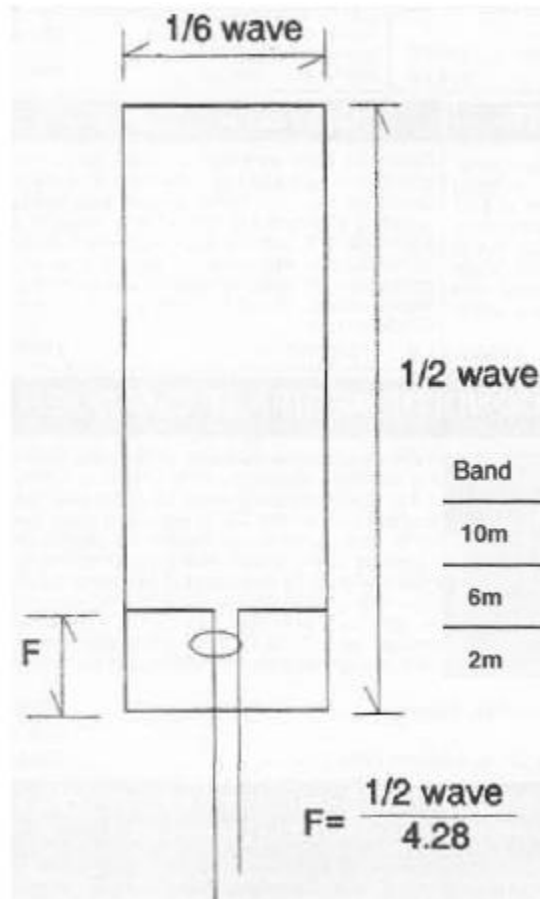

Band	1/2 wave	1/6 wave	Feed point
10m	16' 6"	5' 6"	3' 10-1/4"
6m	8' 10"	2' 11-1/4"	2' 1/16 "
2m	3' 3"	1' 1"	9' 1/8"

Dimensions in Feet

142 - VK2AAR Wire Antenna for 20m

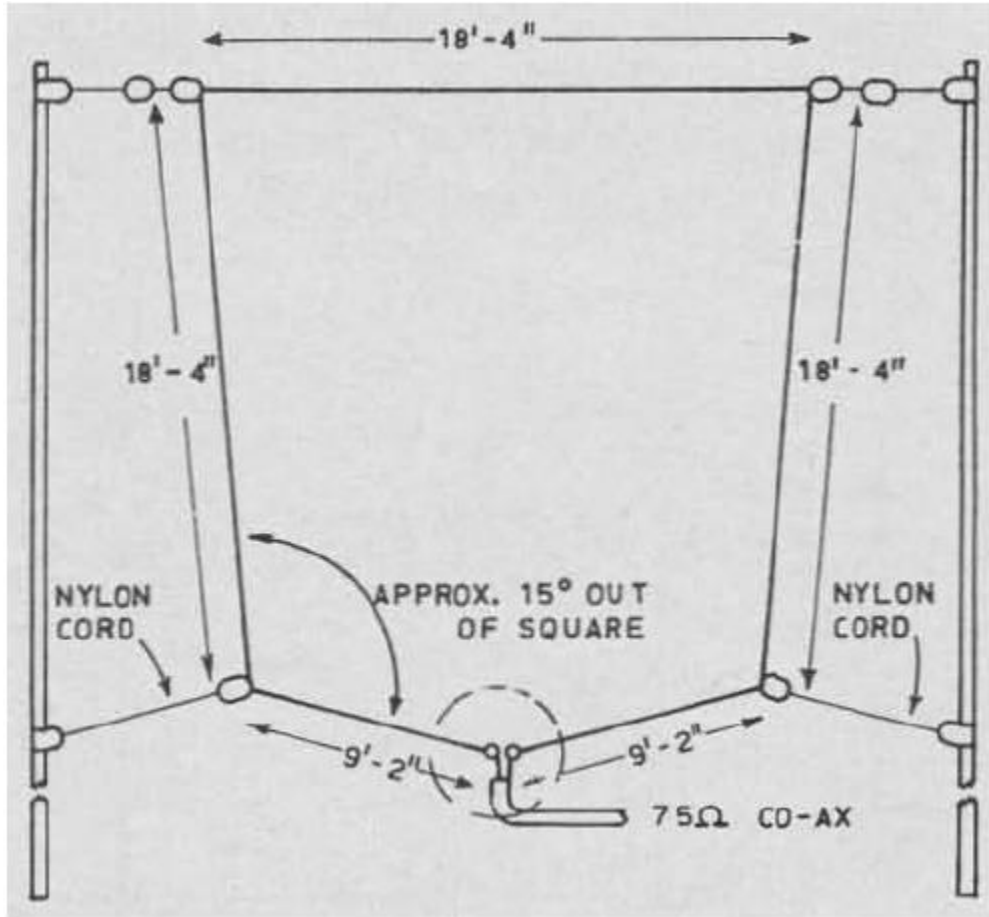

143 - 2-Elements Quad Antenna for 6m

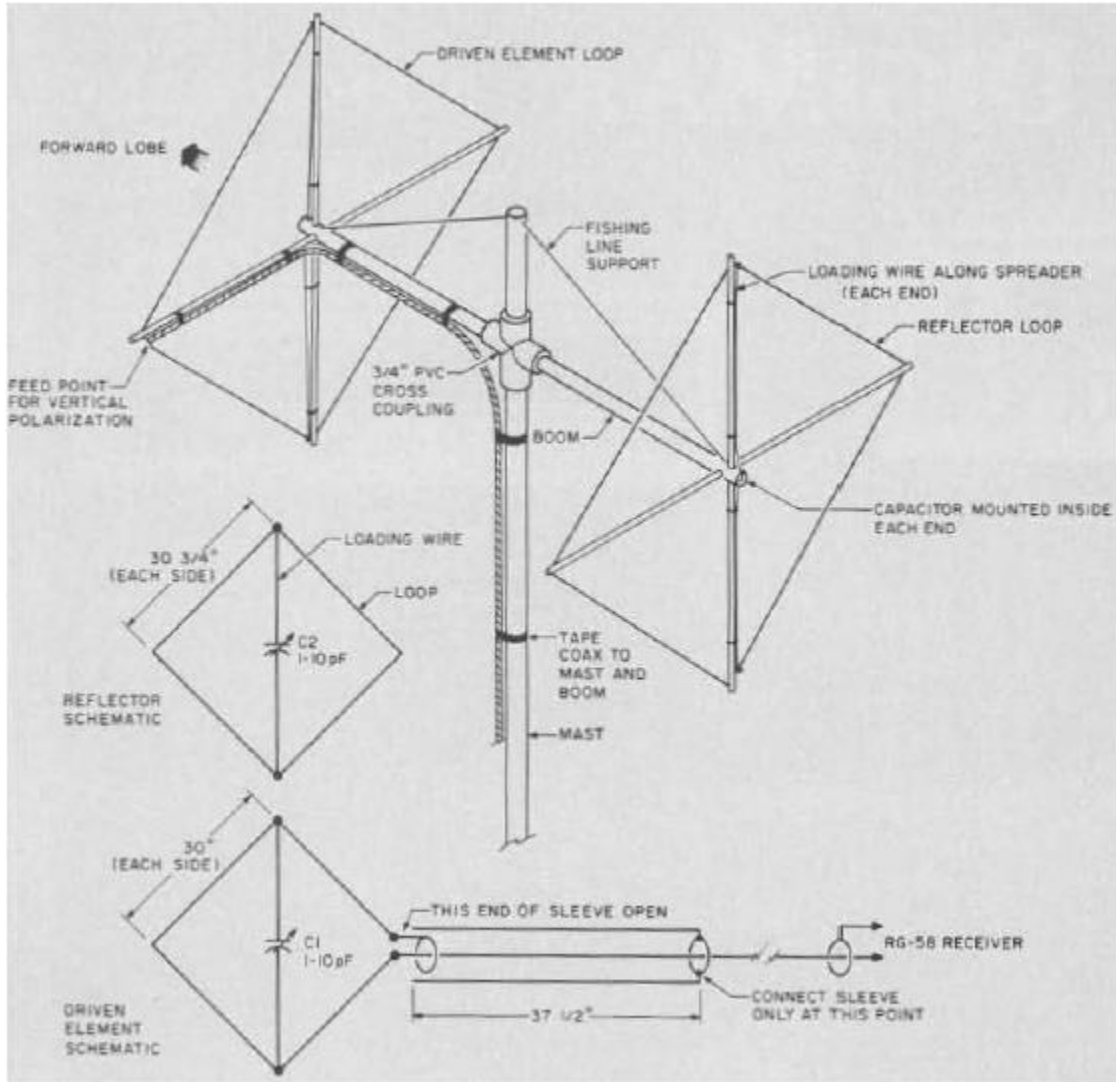

144 - Hula-Loop Bidirectional 6dB-Gain Antenna for 17m

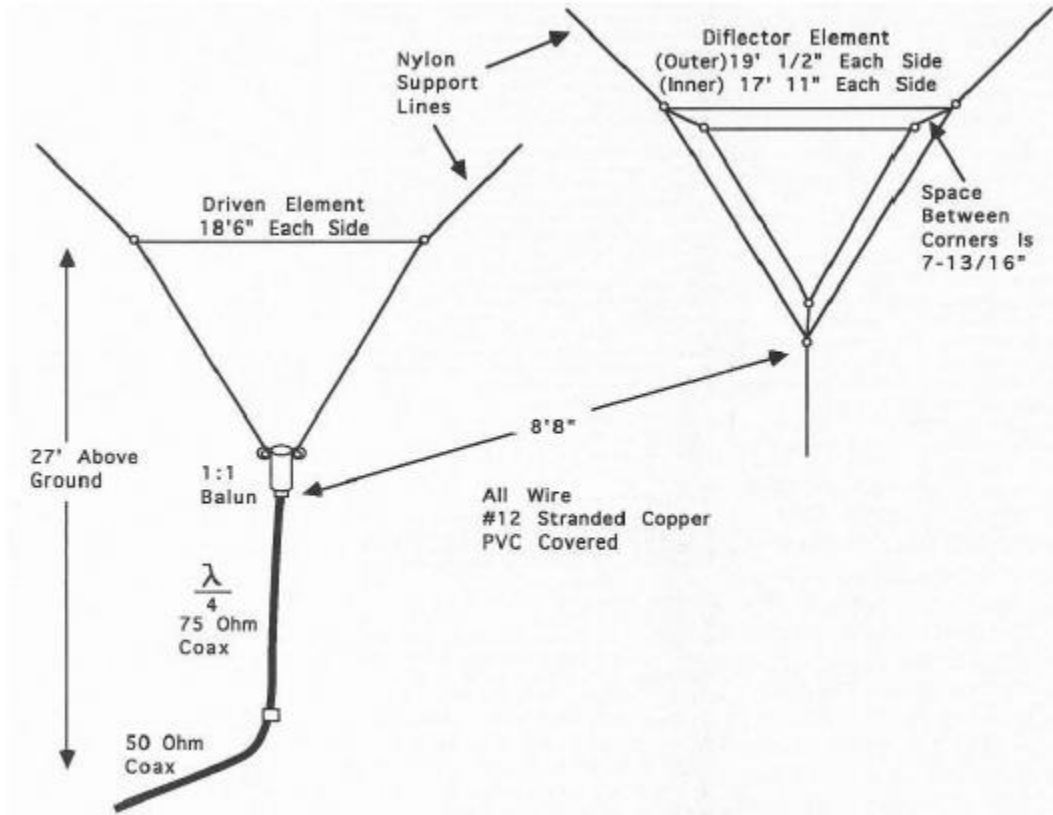

145 - Moxon Rectangle Beam for 15m-10m

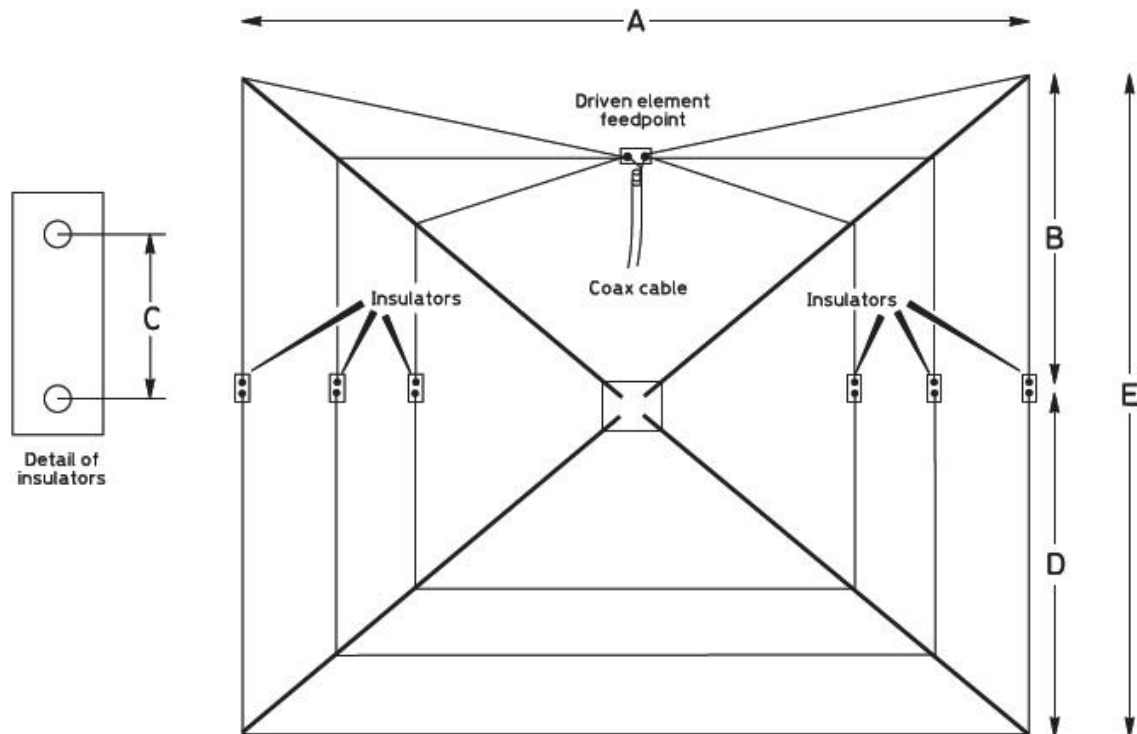

$A = 98.26/f = (\text{m}); 322/f = (\text{ft})$ $56.09/f = \text{length of diagonal in metres}$
 $E = 53.96/f = (\text{m}); 177/f = (\text{ft})$ $184/f = \text{diagonal length in ft.}$
 $C = 560\text{mm (22in)}$ for 14MHz, 380mm (15in) for 21MHz and 250mm (10in) for 28MHz

146 - Double-D Beam 4dB-Gain

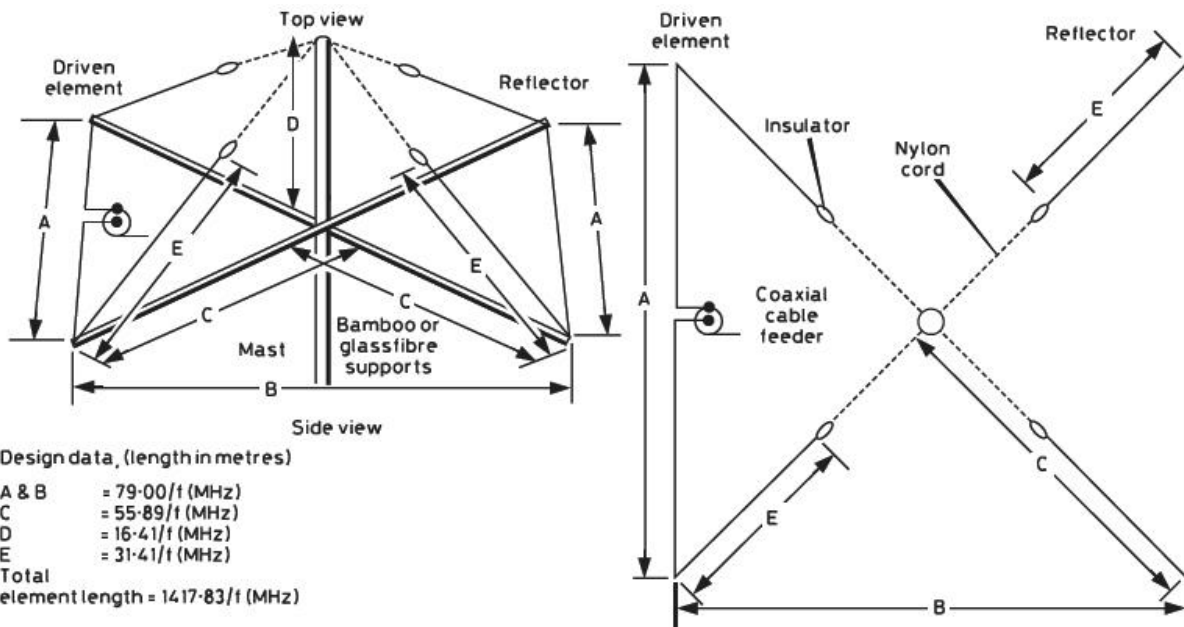

147 - KE4PT OCEF All-Band Dipole

KE4PT OCEF All-band Dipole

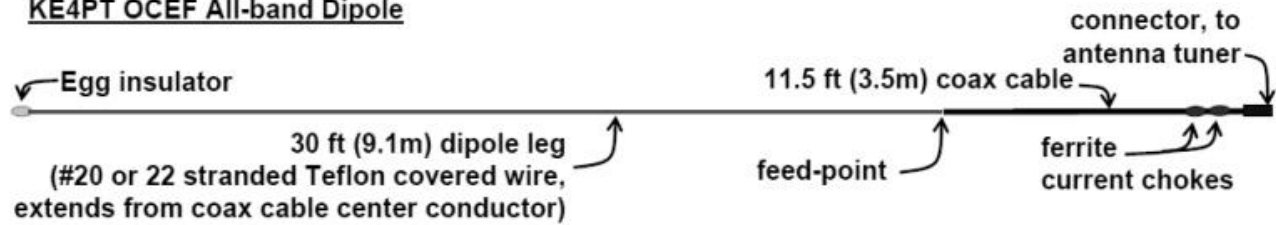

KE4PT Off center end fed (OCEF) All-band Dipole

Lengths are not critical, as long as they are not near a half wavelength on any frequency used. Dipole radiating length is $30+11.5=41.5$ ft, or 12.6 m.

Coax cable may be 50 or 75 ohm on left side of connector, short 50 ohm coax to antenna tuner. Use antenna tuner for operation on any ham band 40m – 6m.

May be hung by Egg insulator at one end, or draped and drooped over a fiberglass pole.

148 - Wire Quad Antenna for 40m

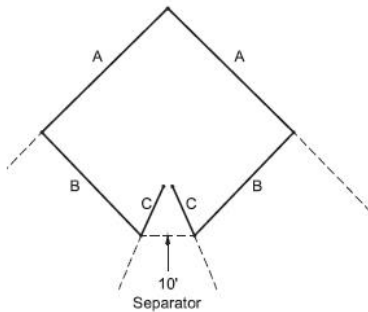
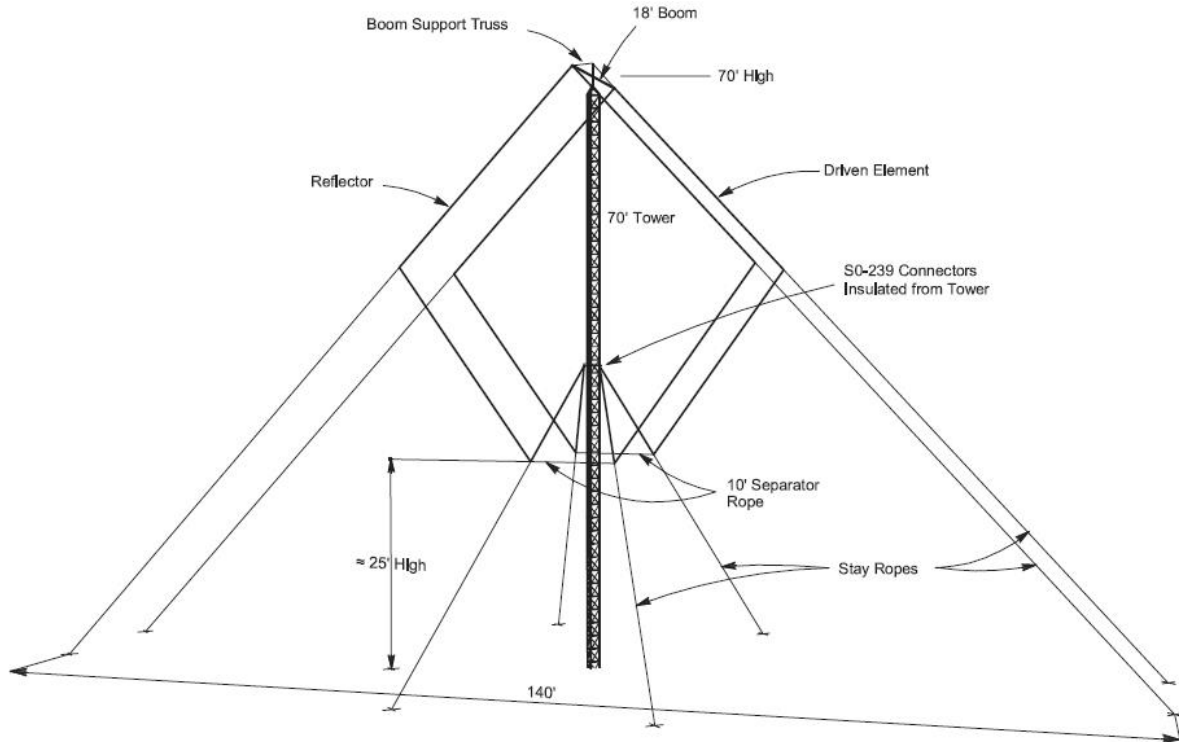

	7050 kHz, CW	7200 kHz, SSB
Length A, Reflector	31"6"	30"10-3/4"
Length B, Reflector	28"2-1/4"	27"7"
Length C, Reflector	15"7-1/4"	15"
Total, Half Reflector	75"3-1/2"	73"5-3/4"
Resonant Frequency	7030 kHz	7205 kHz
Length A, Driven	30"7-1/4"	30"
Length B, Driven	27"3-1/2"	26"8-1/2"
Length C, Driven	14"7-1/2"	14"
Length, Half Driven	72"6-1/4"	70"8-1/2"
Self-Resonant Frequency	7295 kHz	7480 kHz

149 - Inclined Dipole Antenna for 80m, 40m

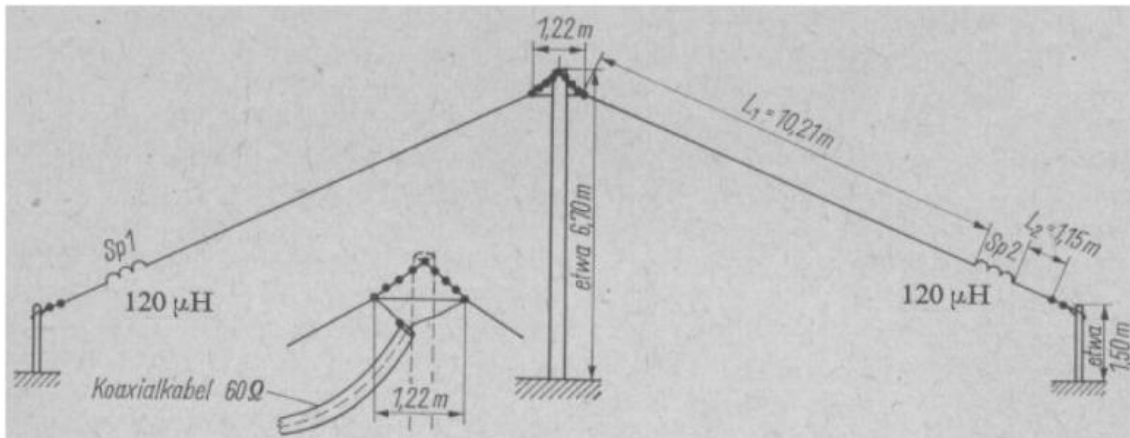

150 - Pyramidal Wire Antenna for 80m

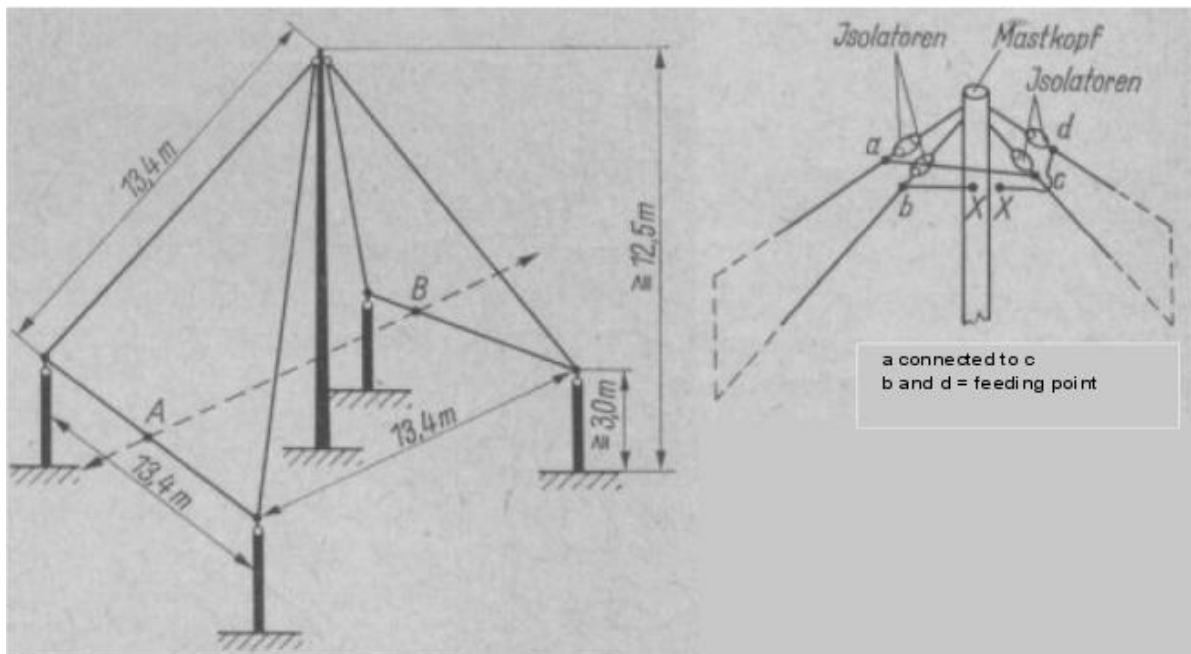

151 - Random Wire Antenna All Bands

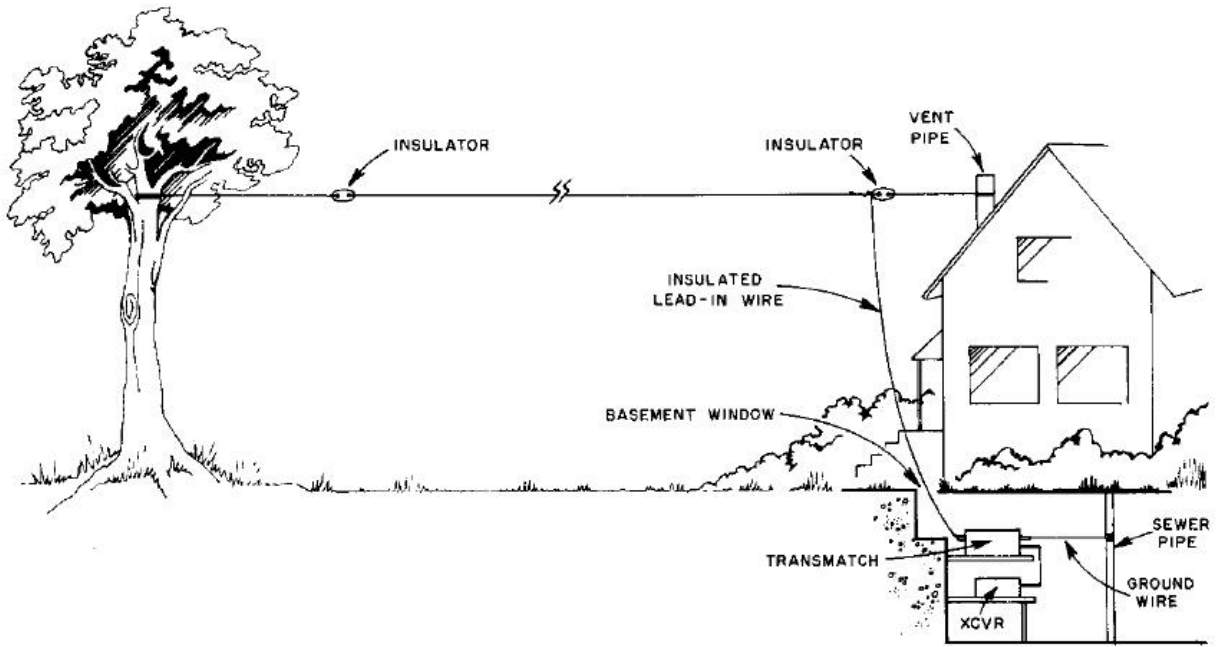

152 - Multiband Dipole Antenna for 80m, 40m, 15m, 10m

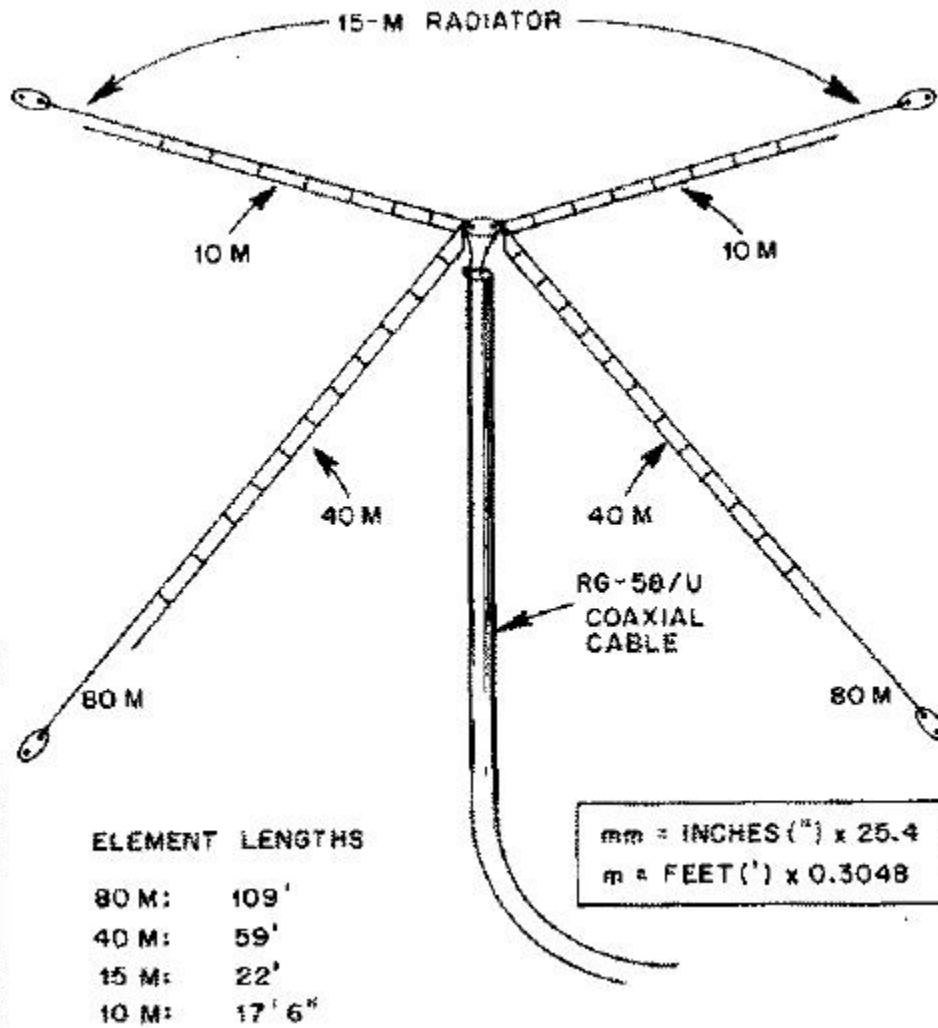

153 - Slim Jim Wire Antenna for 4m

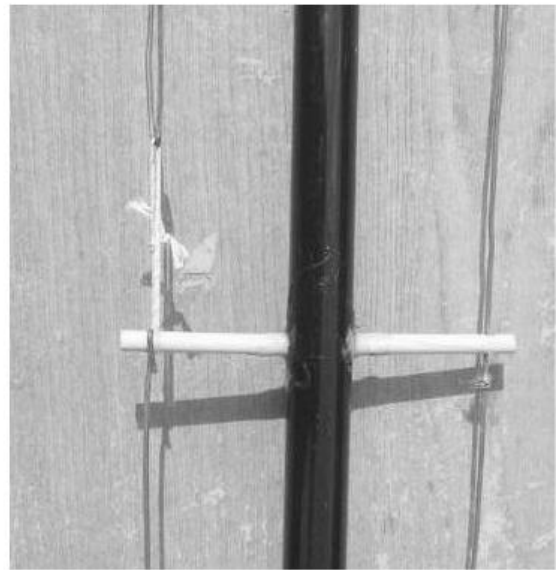
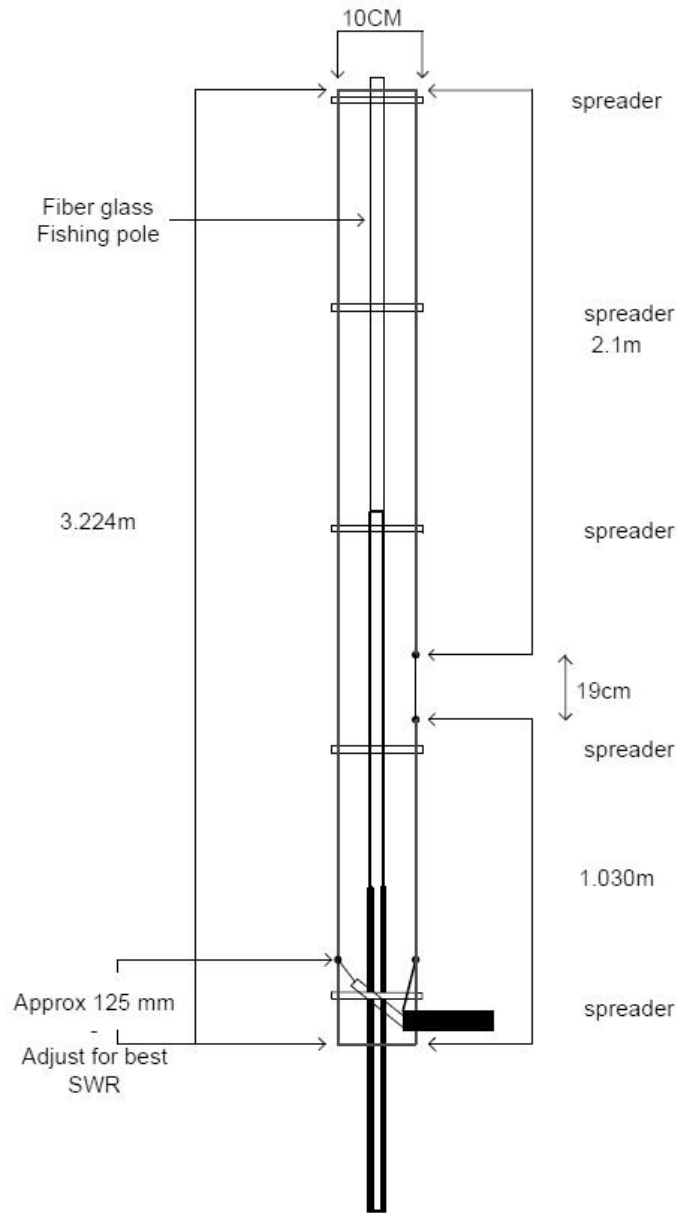

154 - Delta Loop for 6m

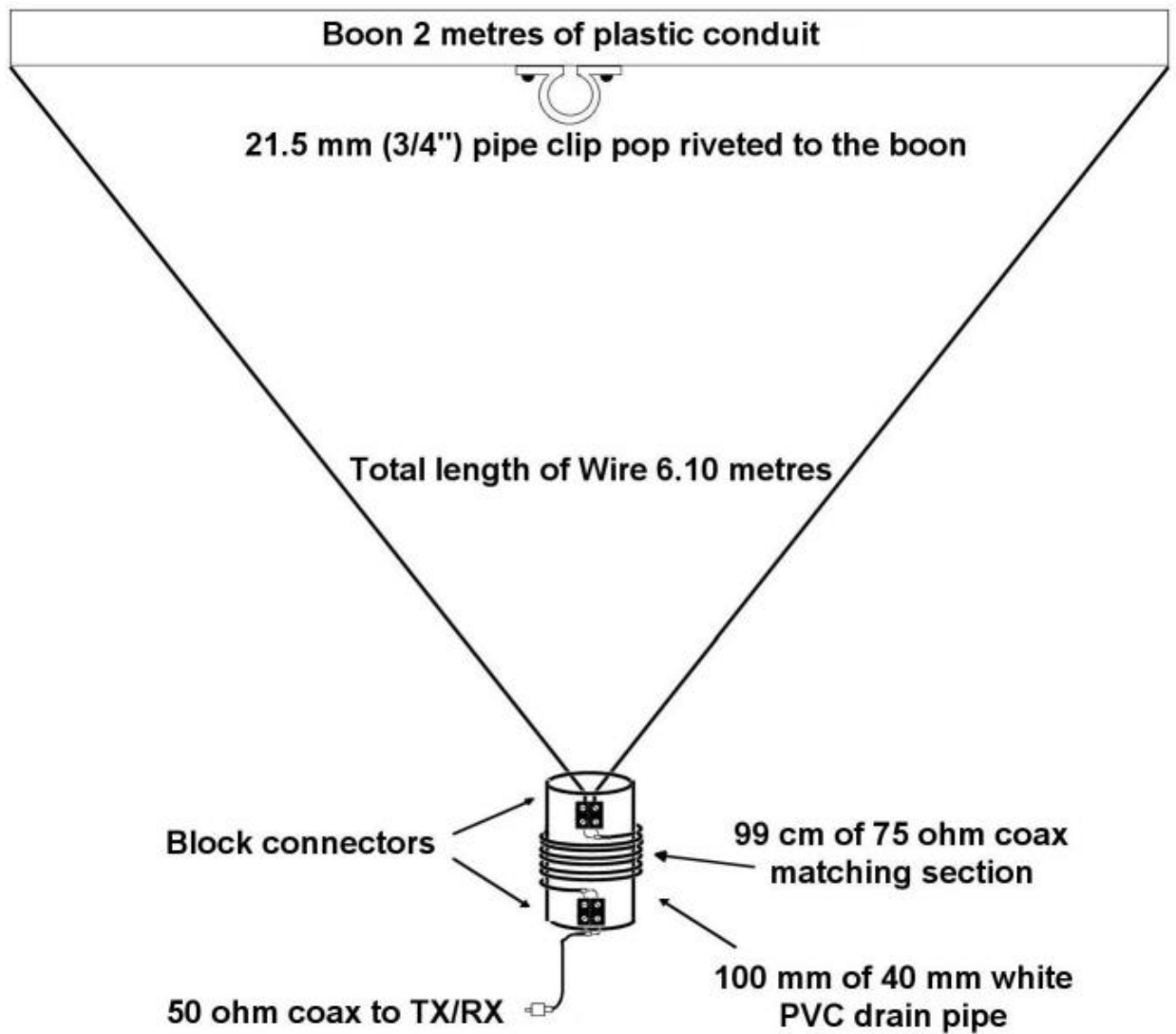

155 - Re-Configurable Antenna for 160m and 80m

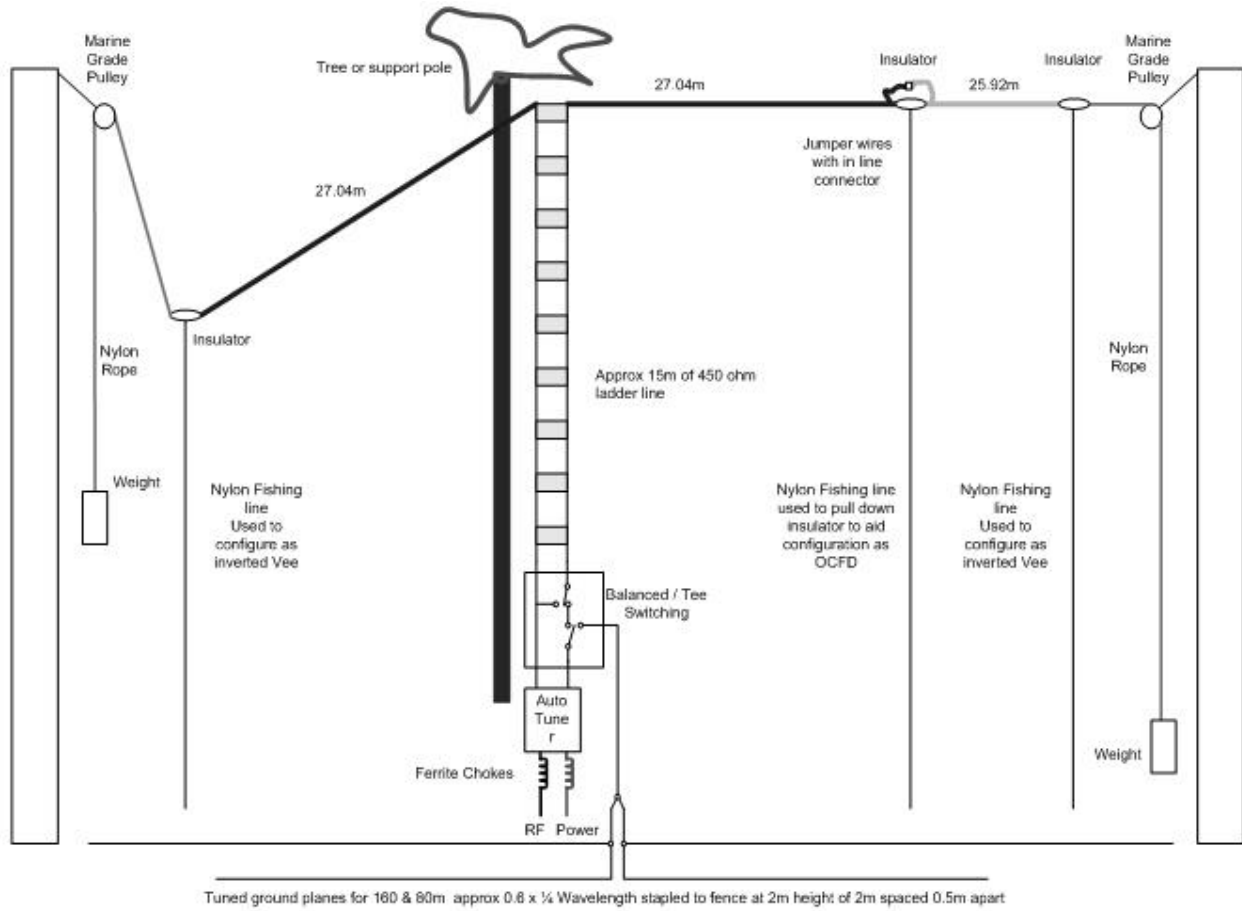

156 - Very Low Frequency Inverted-L Antenna

f(kc)	X (ohms)	CALCULATED Rrad (ohms)
45	-j 785	0.49
50	690	0.60
60	555	0.85
70	450	1.20
80	375	1.55
90	320	2.00
100	268	2.40
120	188	3.6
140	125	5.2
160	75	7.2
180	30	9.9
195	0	12.8

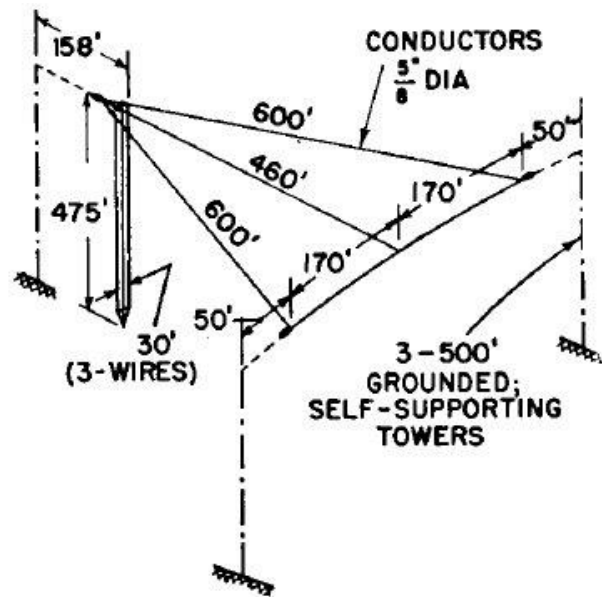

157 - Reduced Size Half Sloper Antenna for 160m

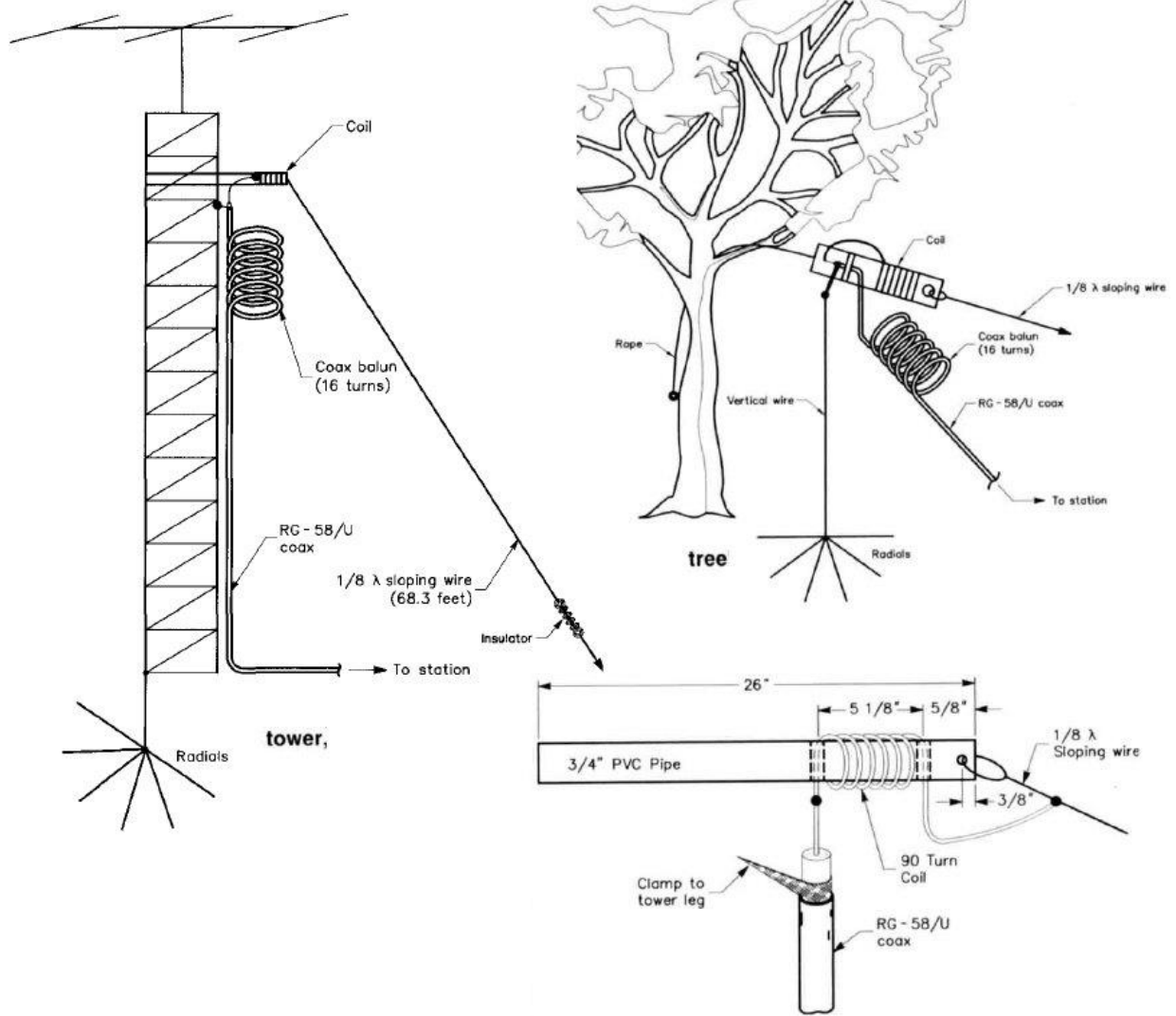

158 - Tree-Mounted HF Antenna

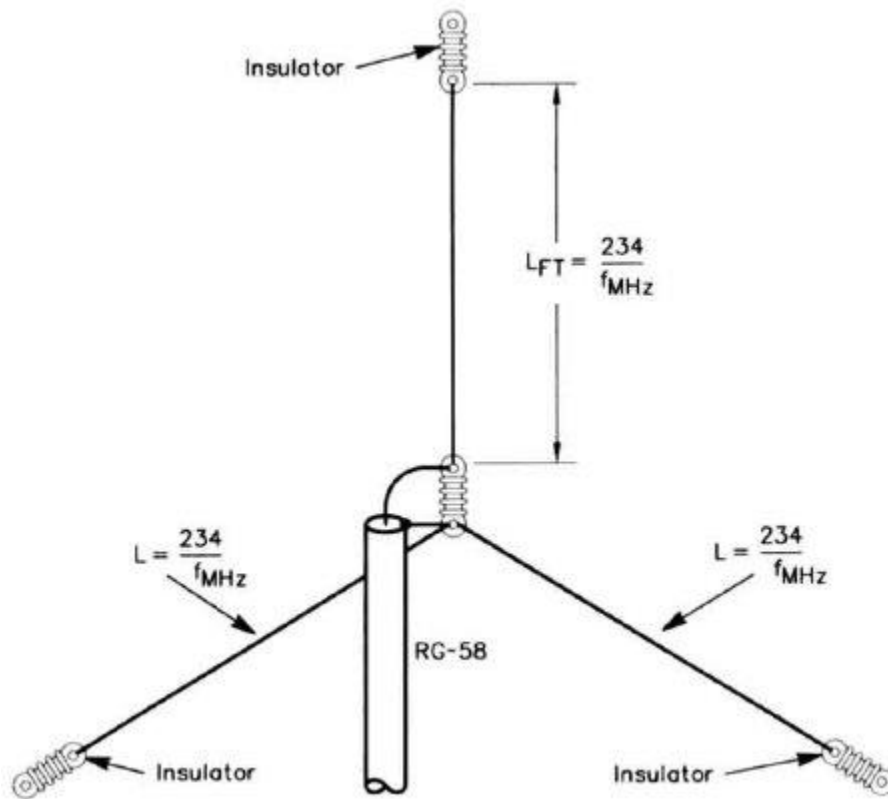

159 - Multiband Vertical Antenna for 80m, 40m, 20m

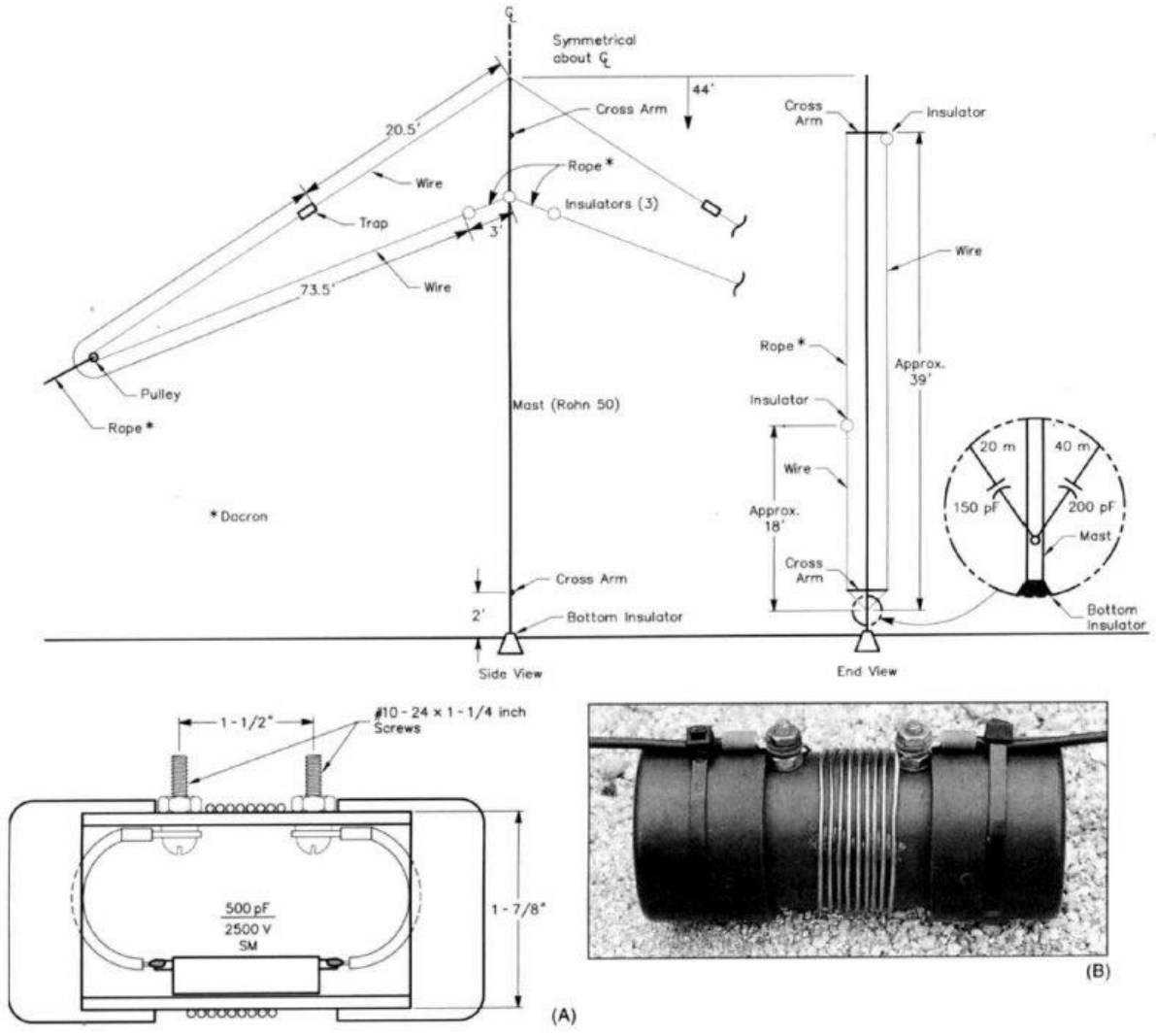

160 - Marconi Antenna for 136 kHz

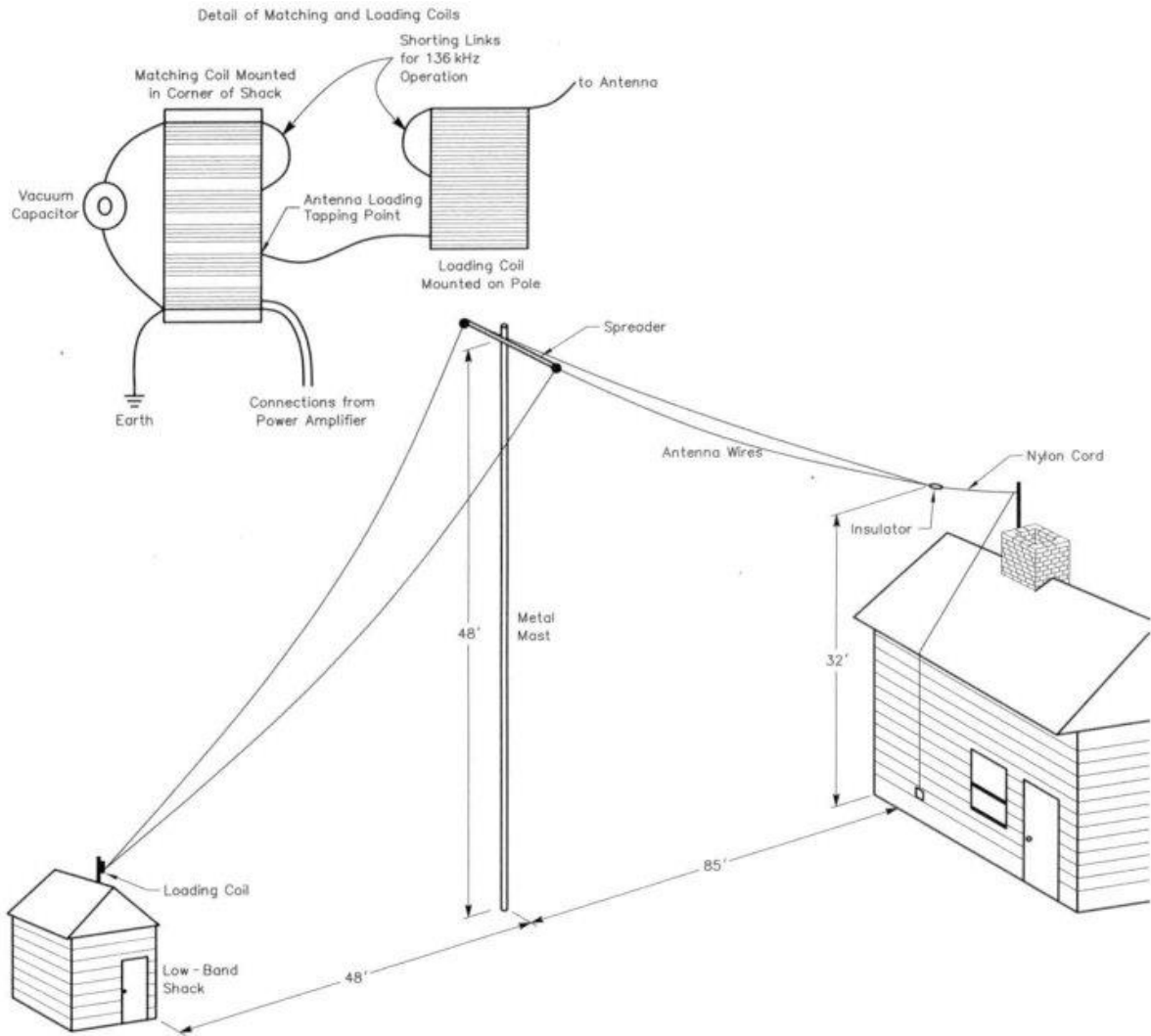

161 - Simple Killer Antenna for 40m

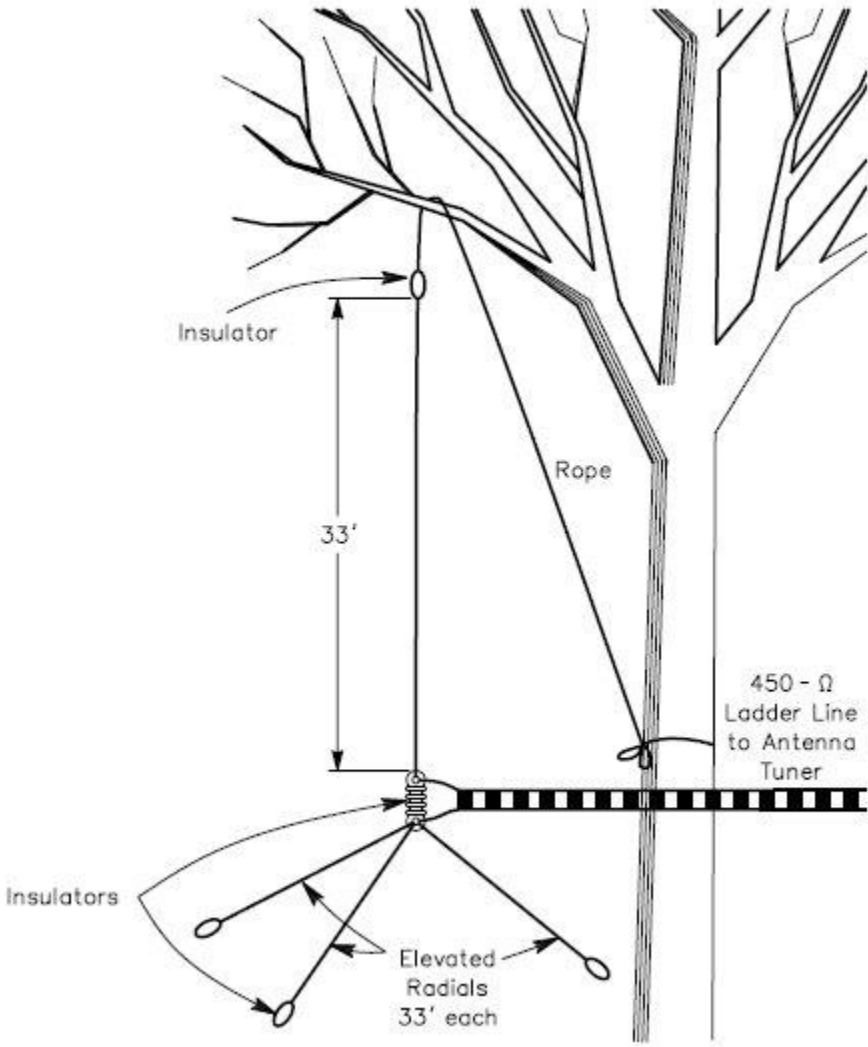

162 - Stub-Directed V Antenna for 80m

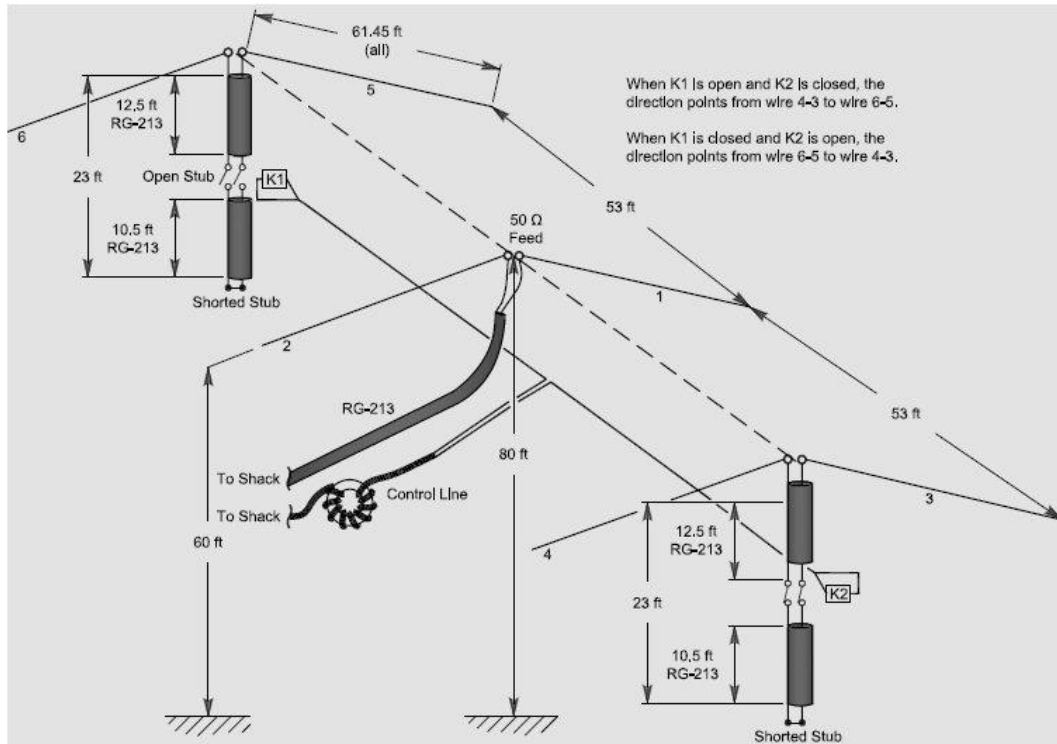

163 - KT0NY Over-and-Under DX Antenna for 20m

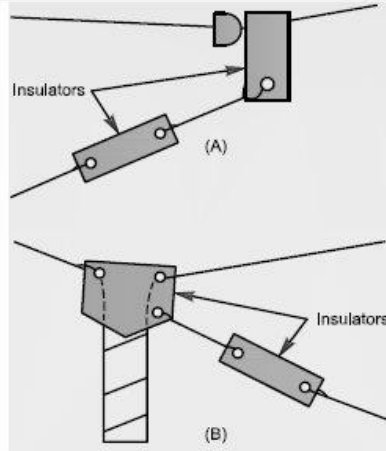
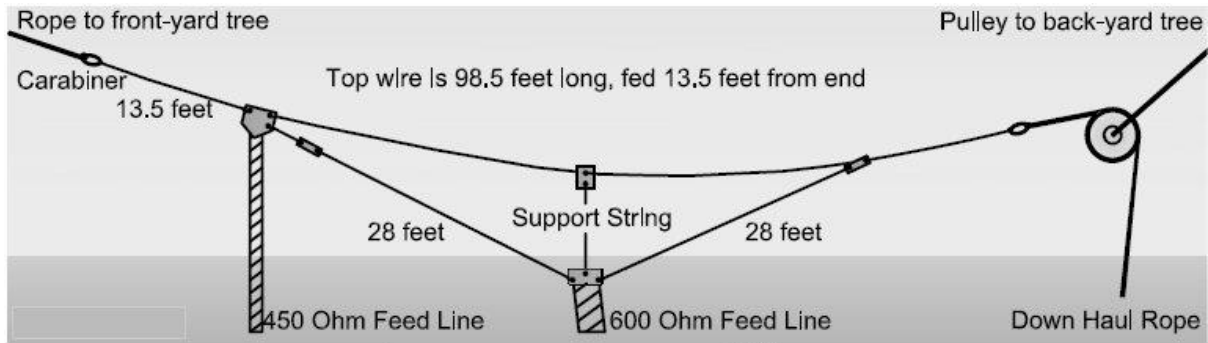

164 - Horizontal Loop Antennas

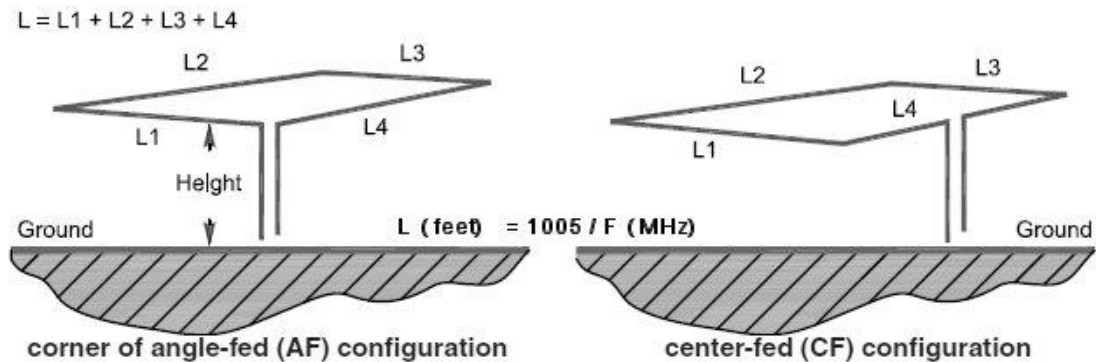

Loop Performance by Shape and Feed Point

	Circular Loop		Square Loop AF		Triangle Loop AF		Square Loop CF		Triangle Loop CF	
	Gain (dBi)	Elev	Gain (dBi)	Elev	Gain (dBi)	Elev	Gain (dBi)	Elev	Gain (dBi)	Elev
1.9 MHz	3.93	90°	3.46	90°	2.88	90°	3.70	90°	2.67	90°
3.9 MHz	8.47	90°	8.13	90°	7.76	90°	8.23	90°	8.04	90°
7.2 MHz	7.76	50°	7.35	50°	7.98	45°	7.64	45°	7.30	45°
10.1 MHz	8.34	35°	10.68	35°	7.35	30°	8.17	35°	7.24	30°
14.2 MHz	10.44	25°	12.50	25°	11.27	25°	10.25	25°	8.50	25°
18.1 MHz	11.18	20°	14.03	20°	12.32	20°	11.40	20°	8.84	20°
21.2 MHz	10.16	15°	14.55	15°	12.42	15°	11.28	15°	8.29	15°
24.9 MHz	10.77	15°	13.69	15°	14.09	15°	10.58	15°	10.10	15°
28.5 MHz	11.39	15°	12.85	10°	13.84	10°	11.19	10°	12.66	10°

165 - Ribbon J-Pole for 2m

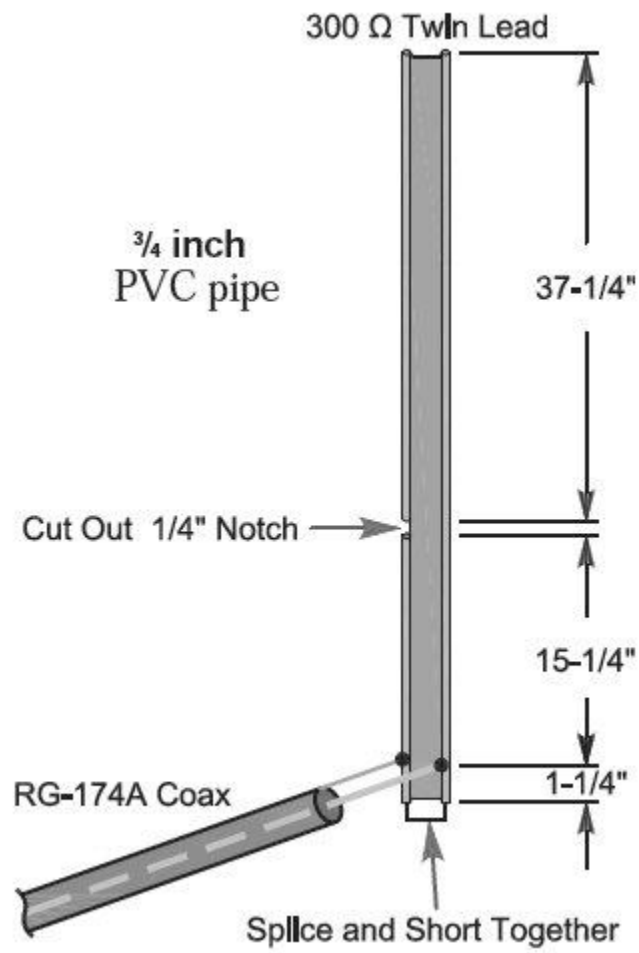

166 - Dual Band Ribbon J-Pole for 2m, 70cm

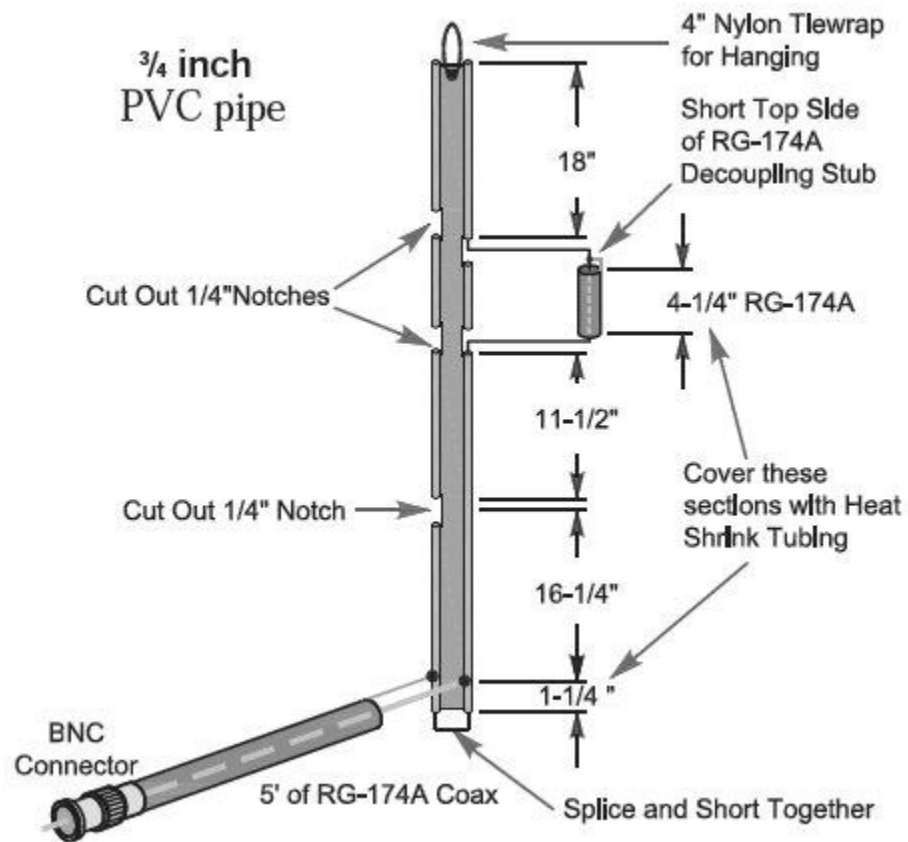

167 - Square Vertical Loop Antenna for 40m

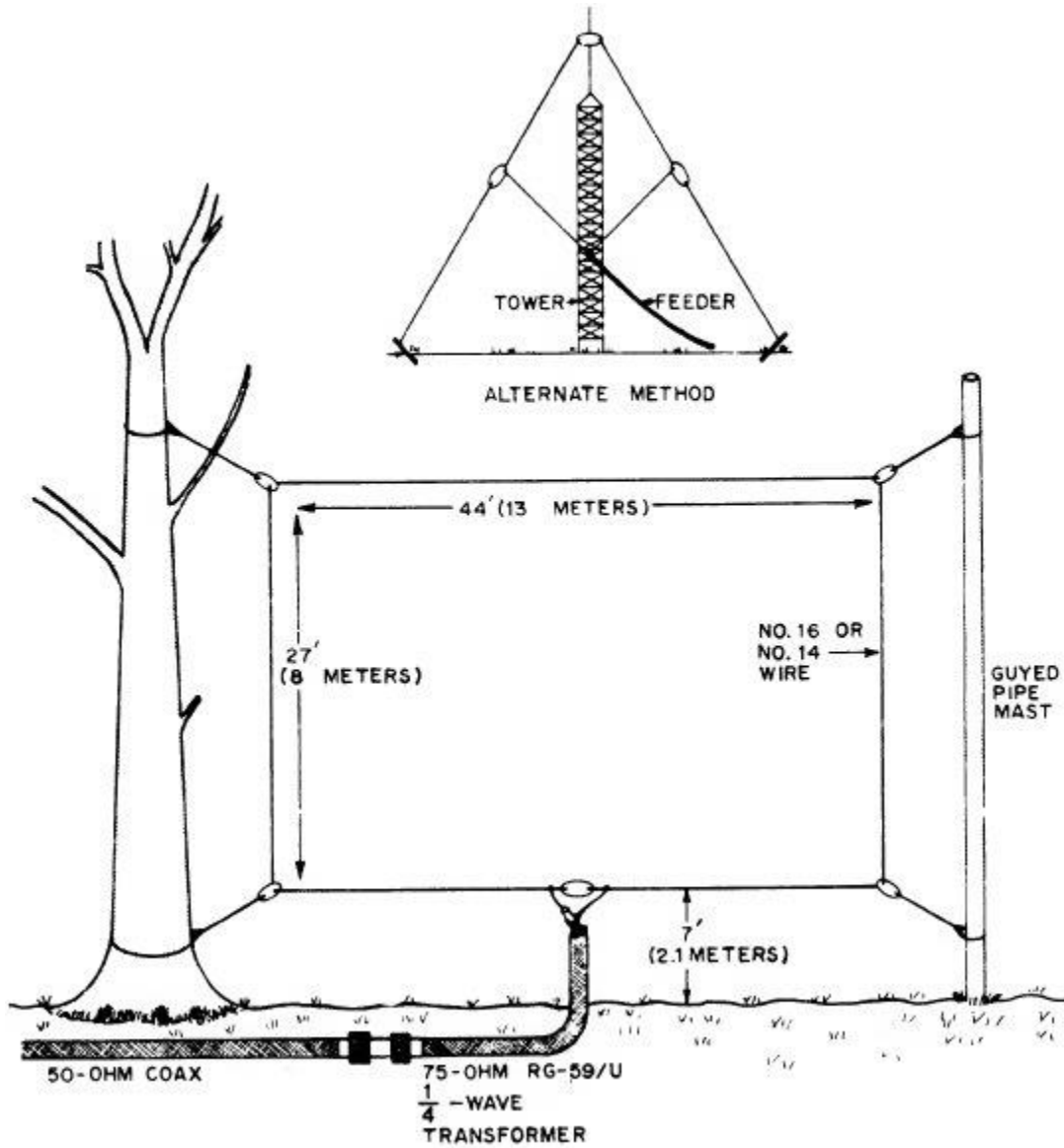

168 - Tri-Band Quad Antenna for 20m, 15m, 10m

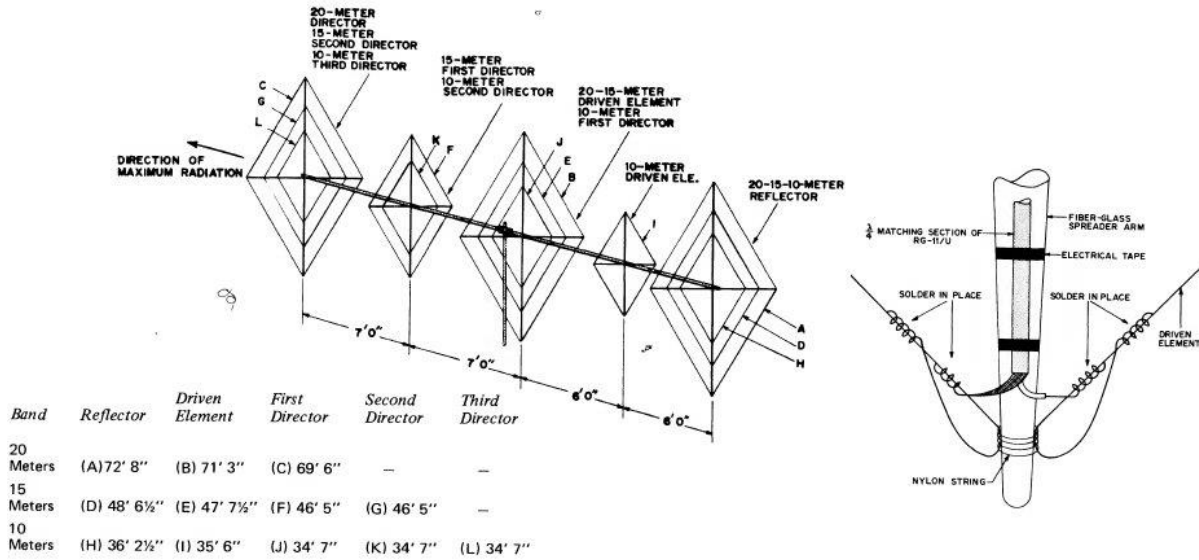

169 - 3D Quad Antenna for 80m, 40m, 20m, 15m, 10m

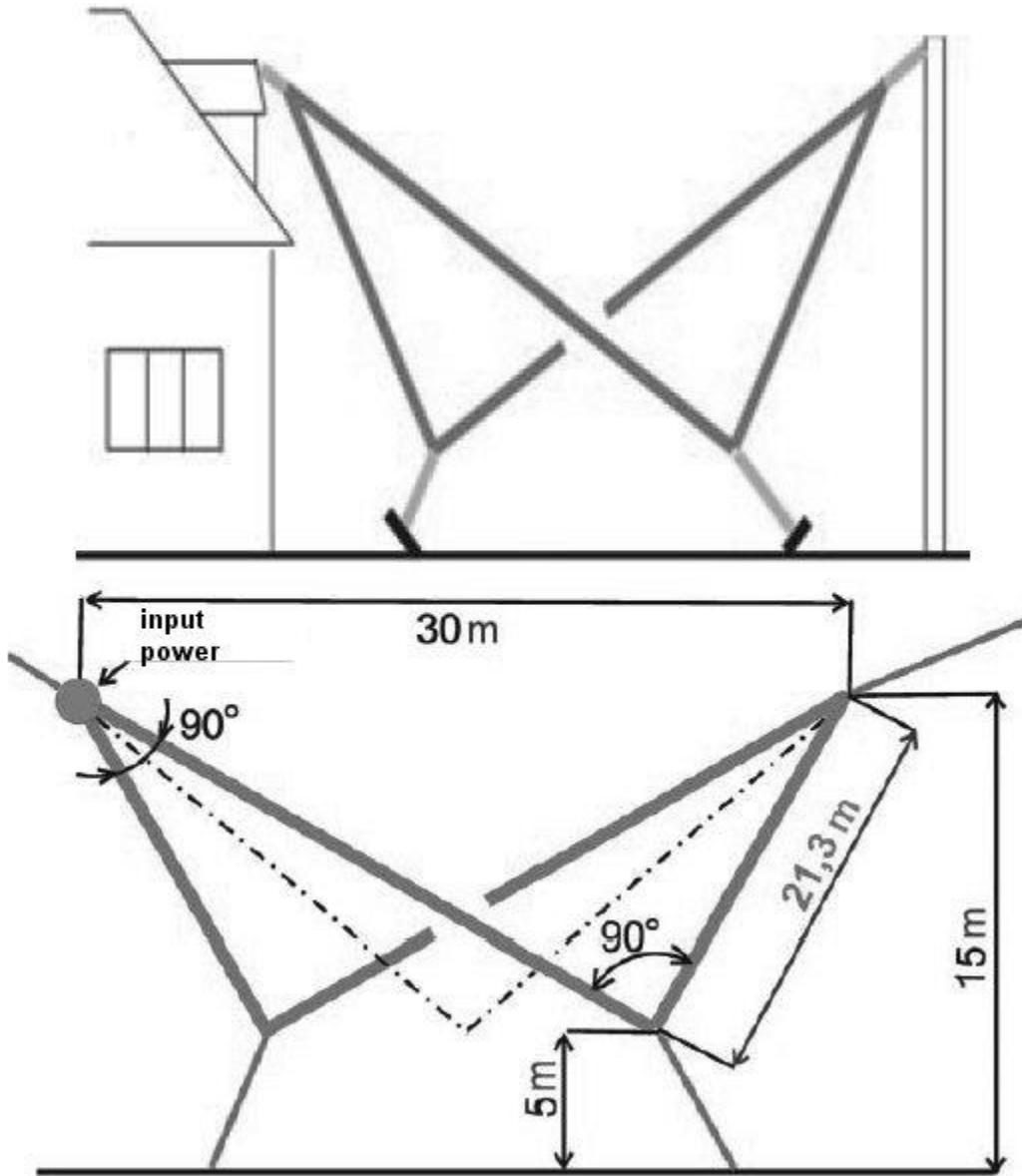

170 - Sloping Wire Antenna for 30m, 20m, 17m, 15m, 12m, 10m

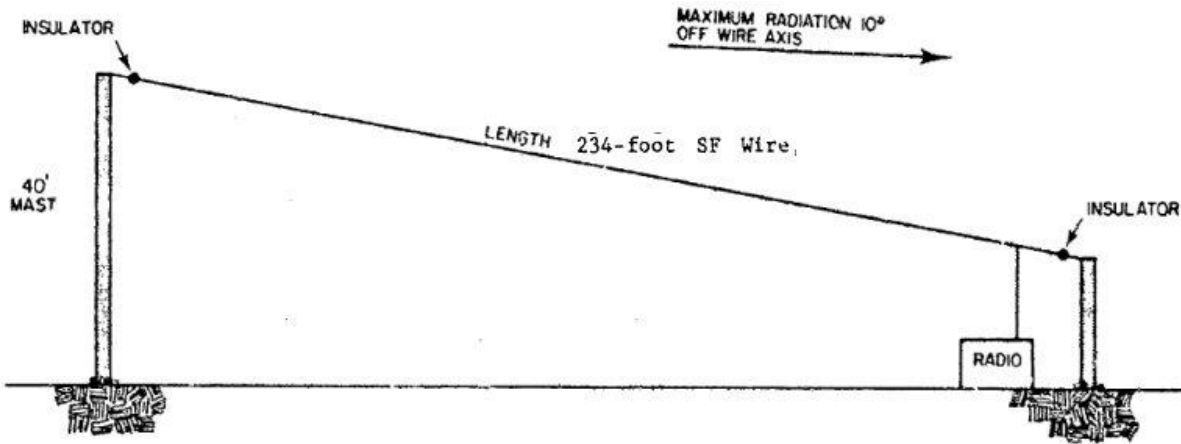

171 - Broadband Dipole Antenna with Coaxial Resonator for 80m

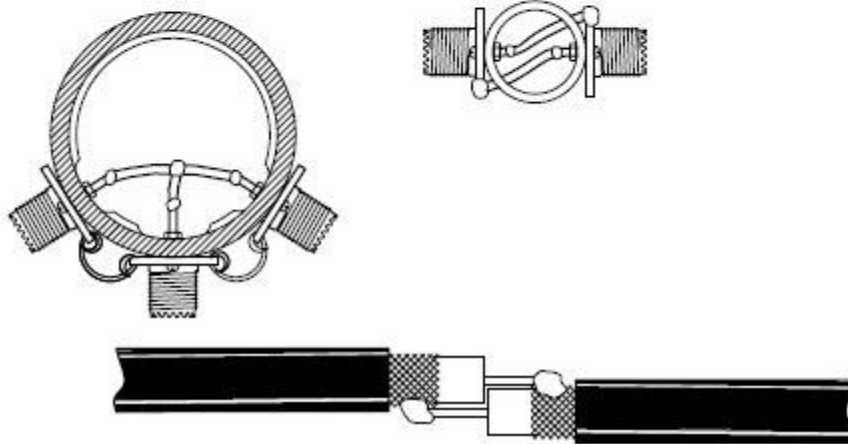
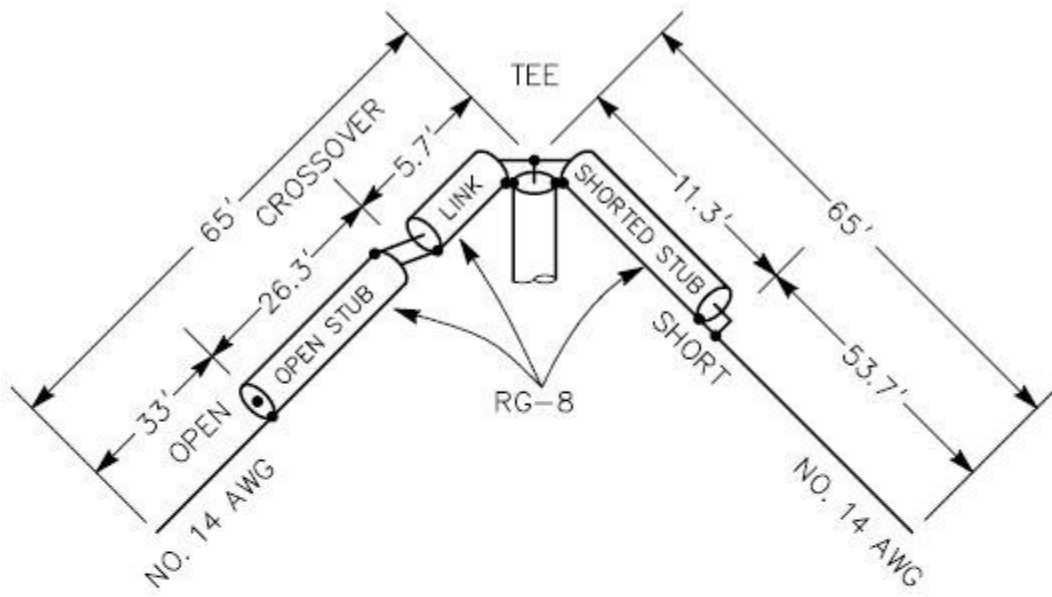

172 - Resonant Feedline Dipole Antenna for 80m

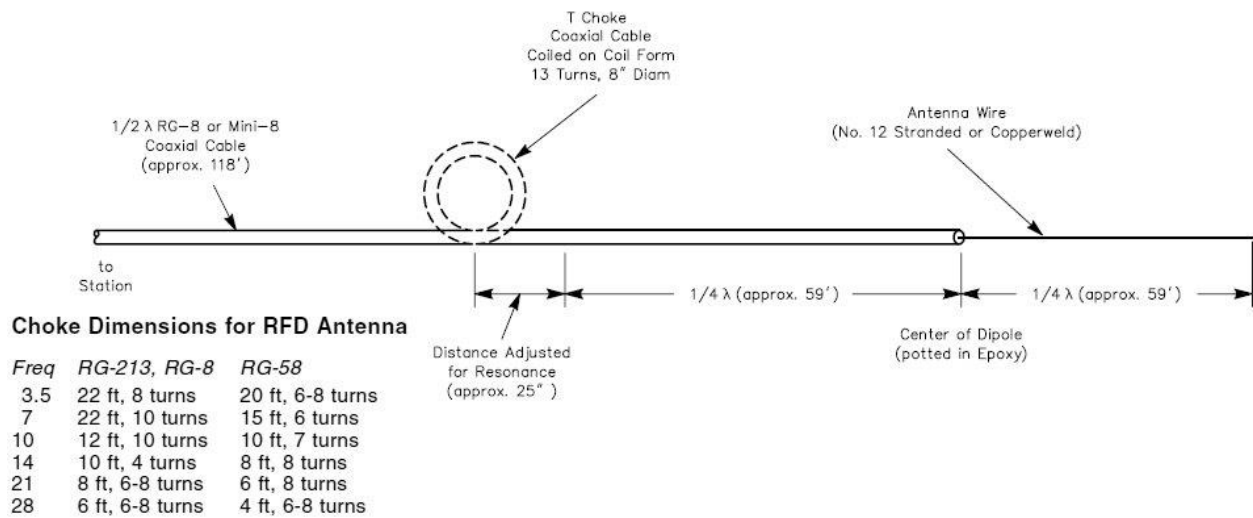

173 - Dual-Band Loading Wire Antenna for 80m, 30m

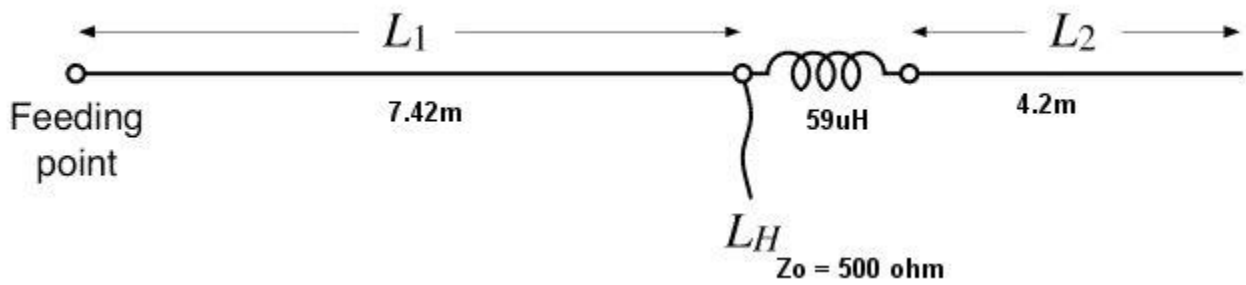

174 - Stub Matching Antennas

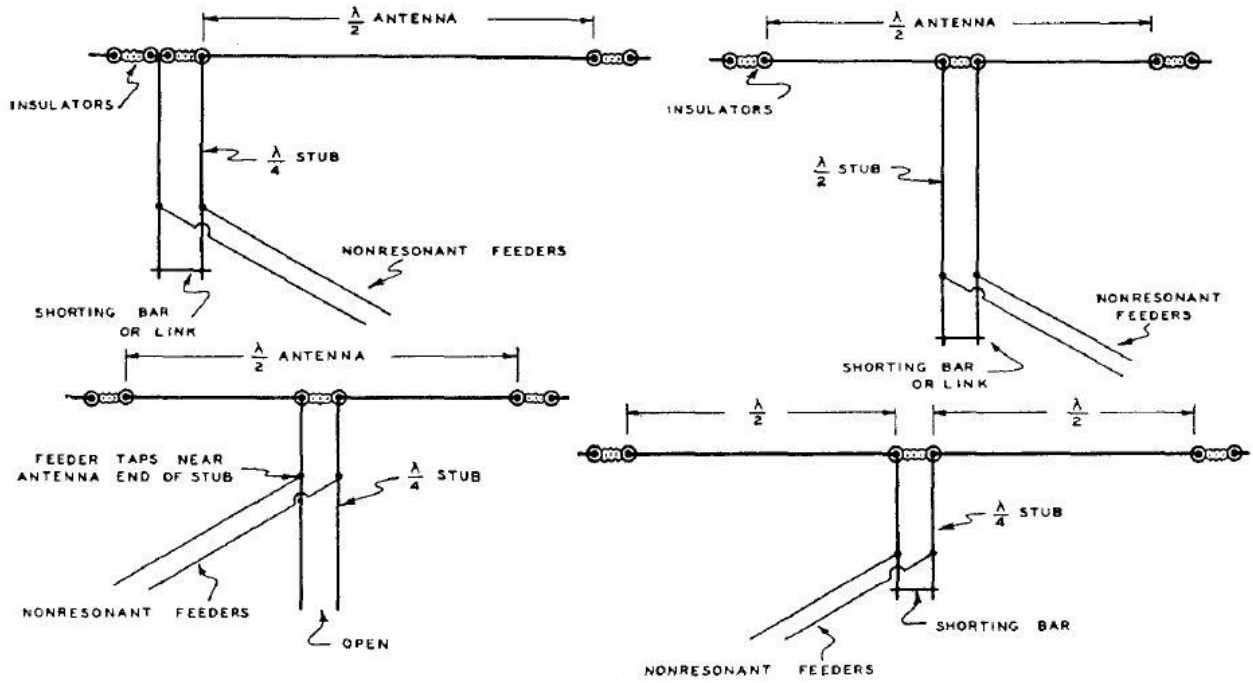

175 - J-Style Vertical Wire Antenna for 10m

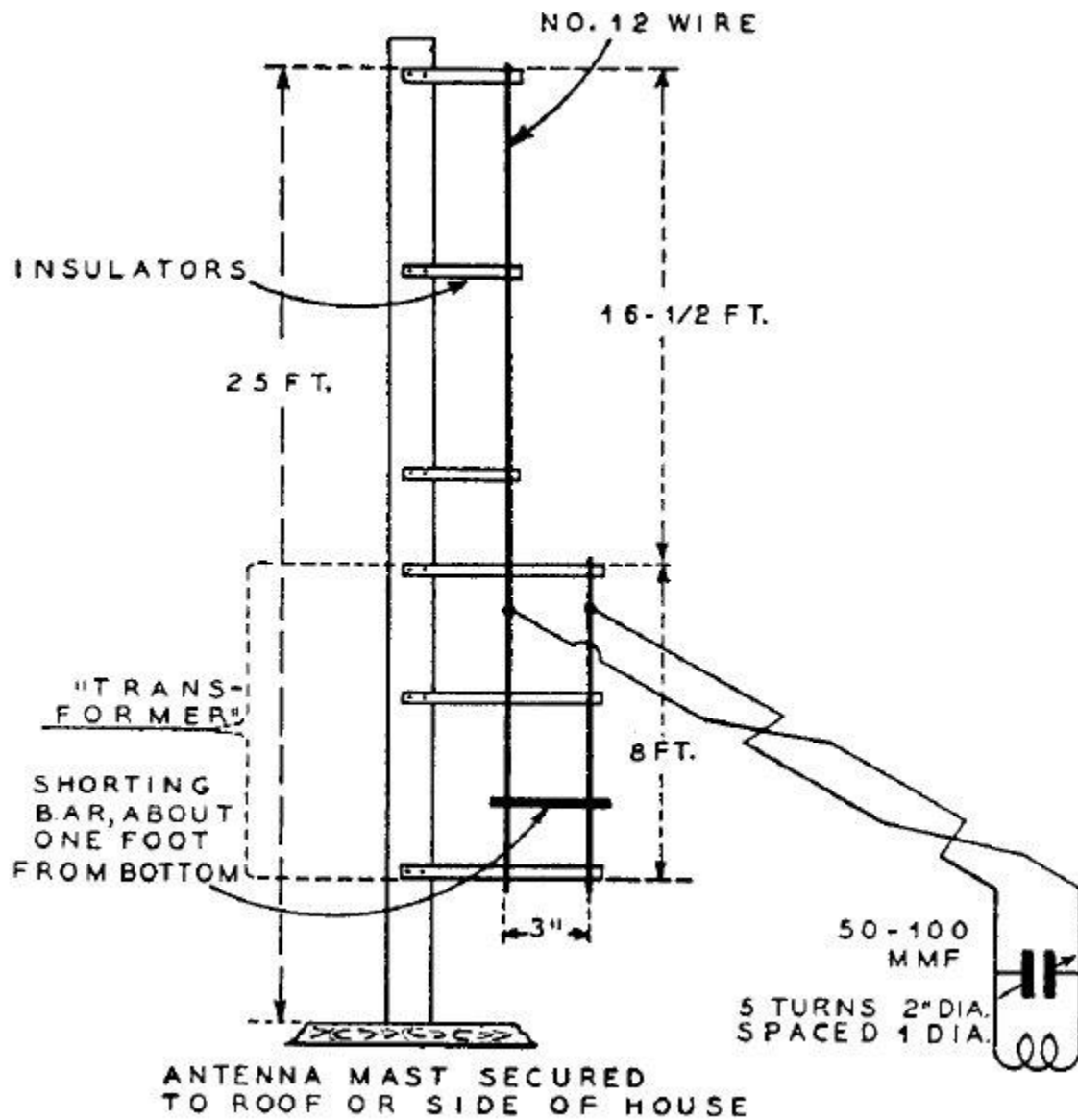

176 - Dual Band Vertical with Zepp Feeders for 40m, 20m

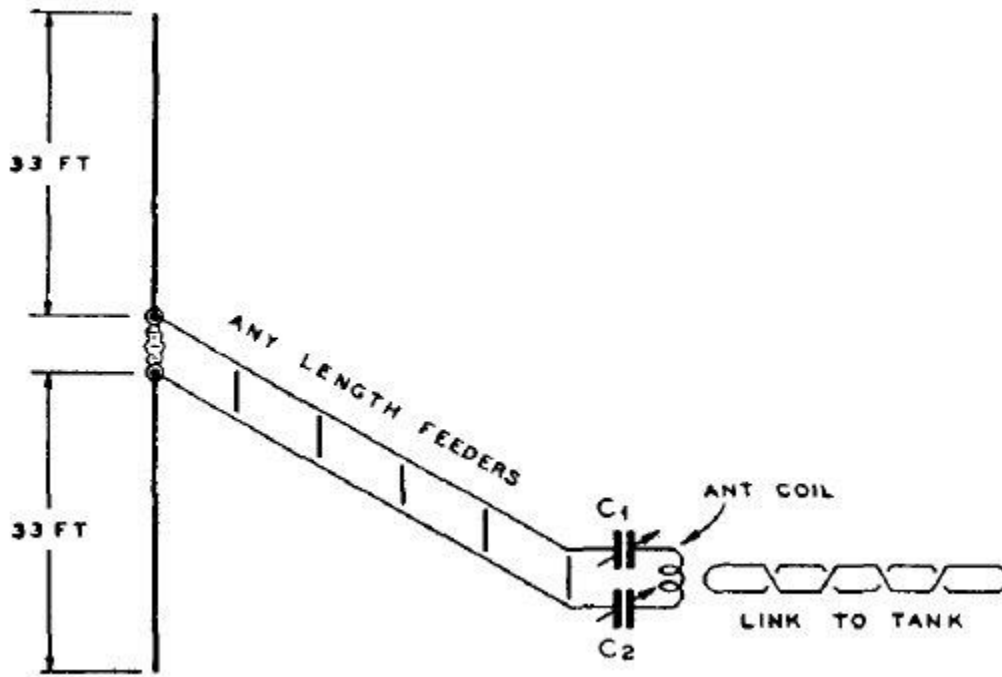

177 - RCA Double Doublet for 40m to 12m

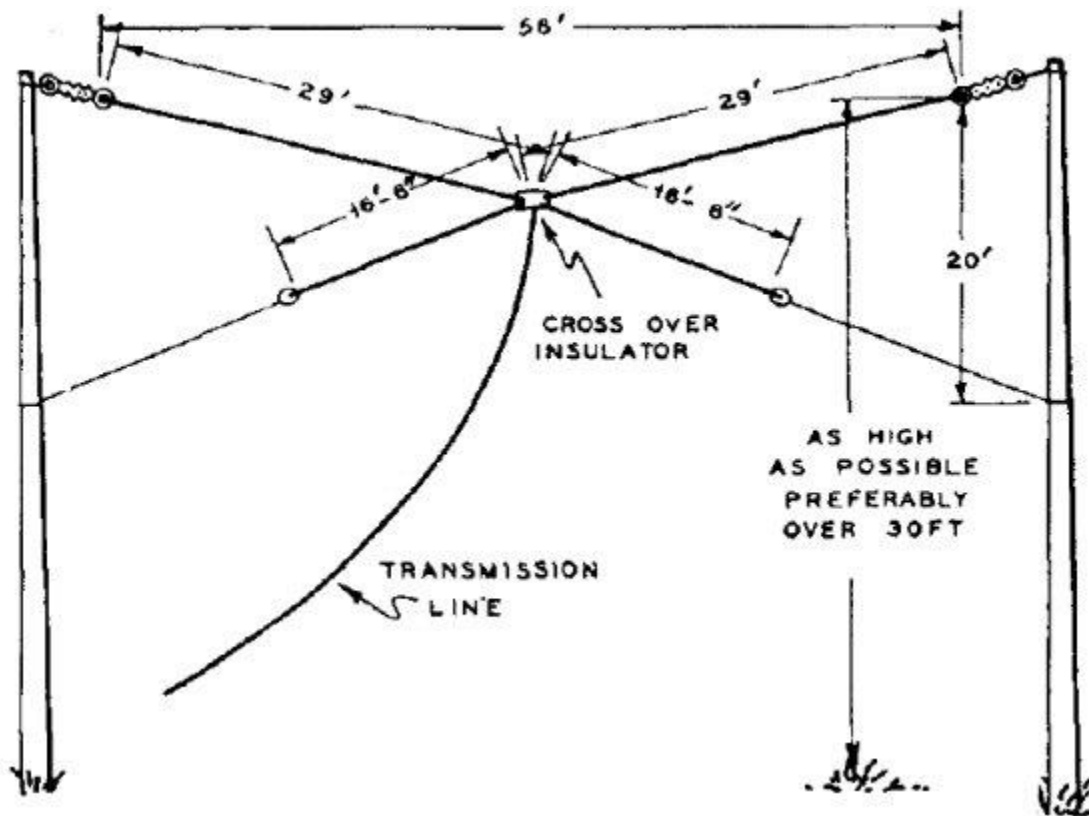

178 - RCA Spiderweb Antenna for 40m to 6m

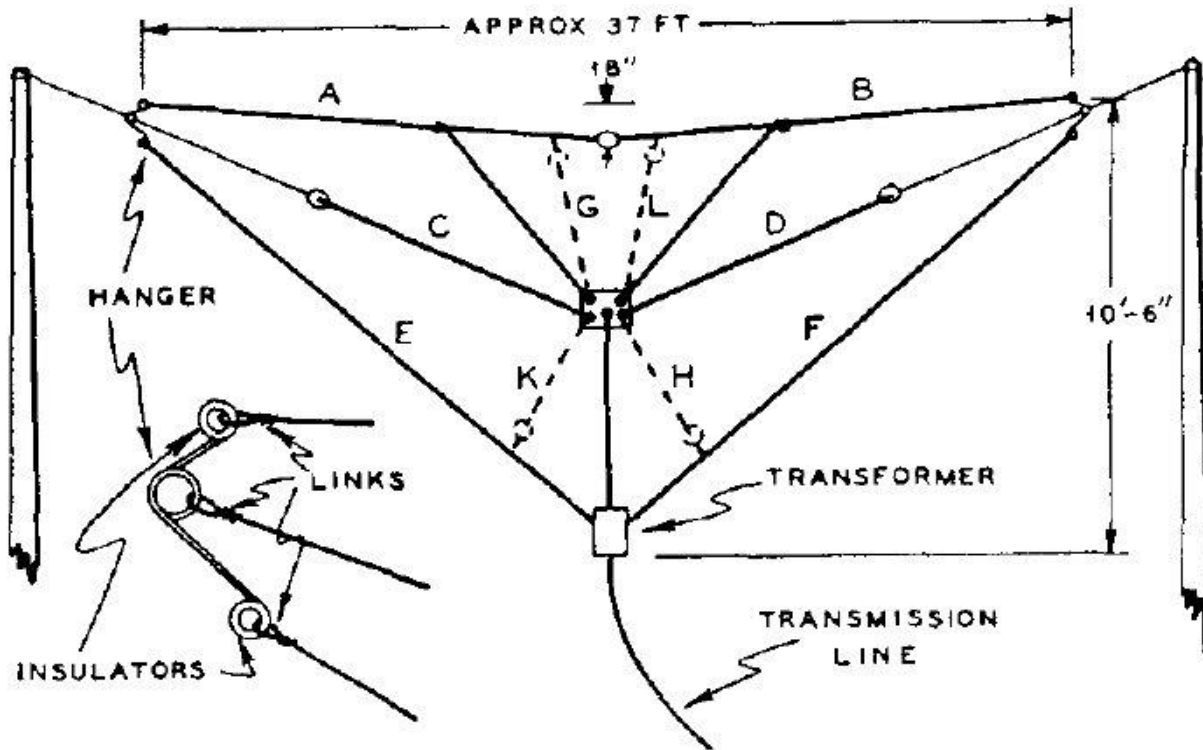

179 - Folded Dipole with Shorted Straps

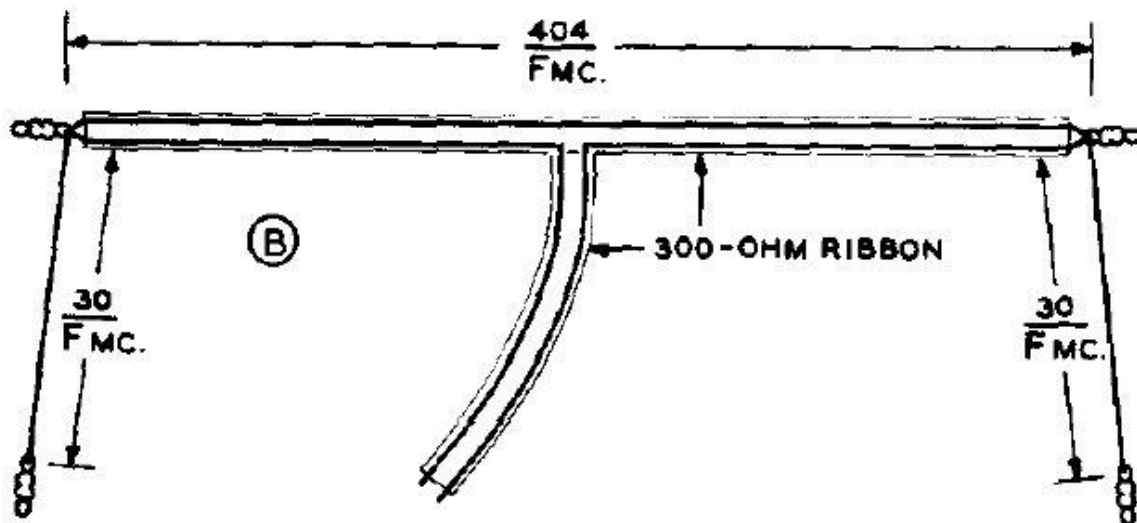

180 - Twin-Lead Marconi Antenna for 160m, 80m

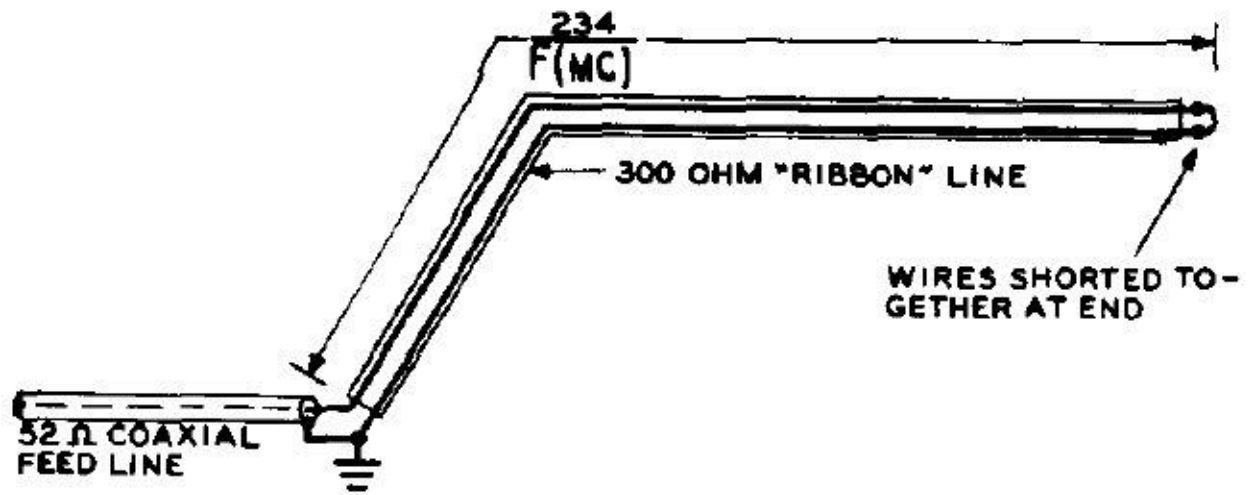

181 - Broadband Antenna Quarter-Wave Balun for 80m

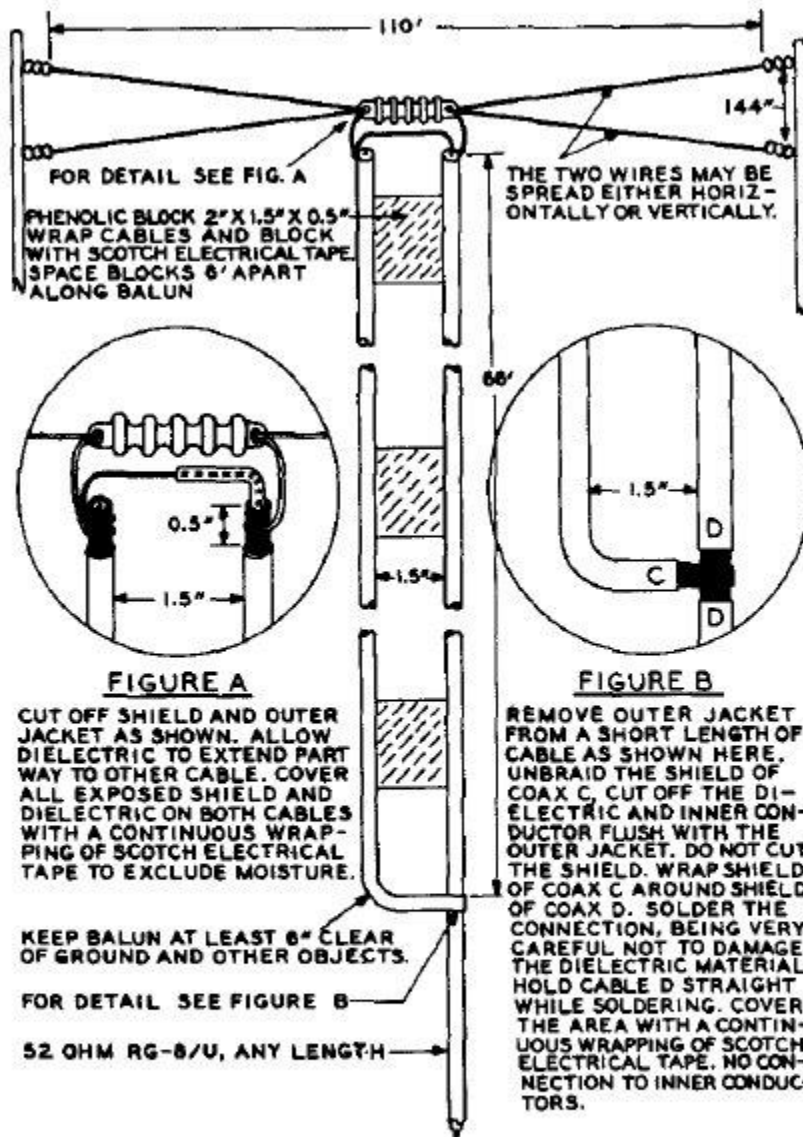

DIMENSIONS SHOWN HERE ARE FOR THE 80 METER BAND. THIS ANTENNA MAY BE BUILT FOR OTHER BANDS BY USING DIMENSIONS THAT ARE MULTIPLES OR SUBMULTIPLES OF THE DIMENSIONS SHOWN. BALUN SPACING IS 1.5" ON ALL BANDS.

182 - Three-Quarter-Wave Folded Doublet for Dual-Band

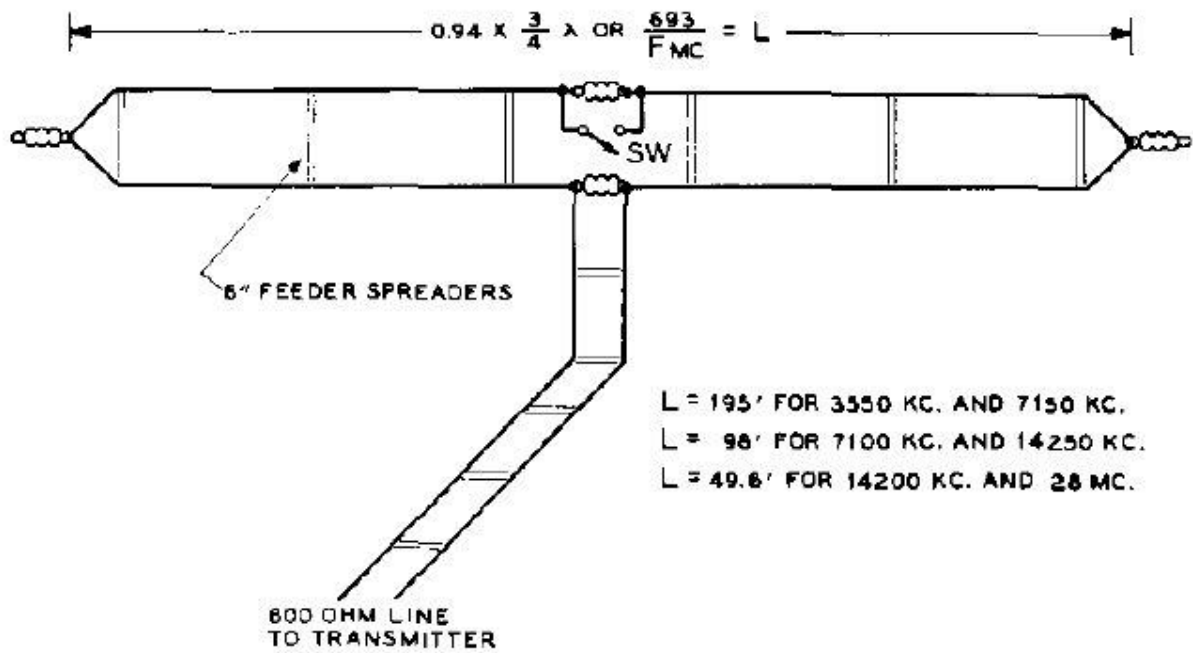

183 - Three-Quarter-Wave Folded Doublet No-Switch for Dual-Band

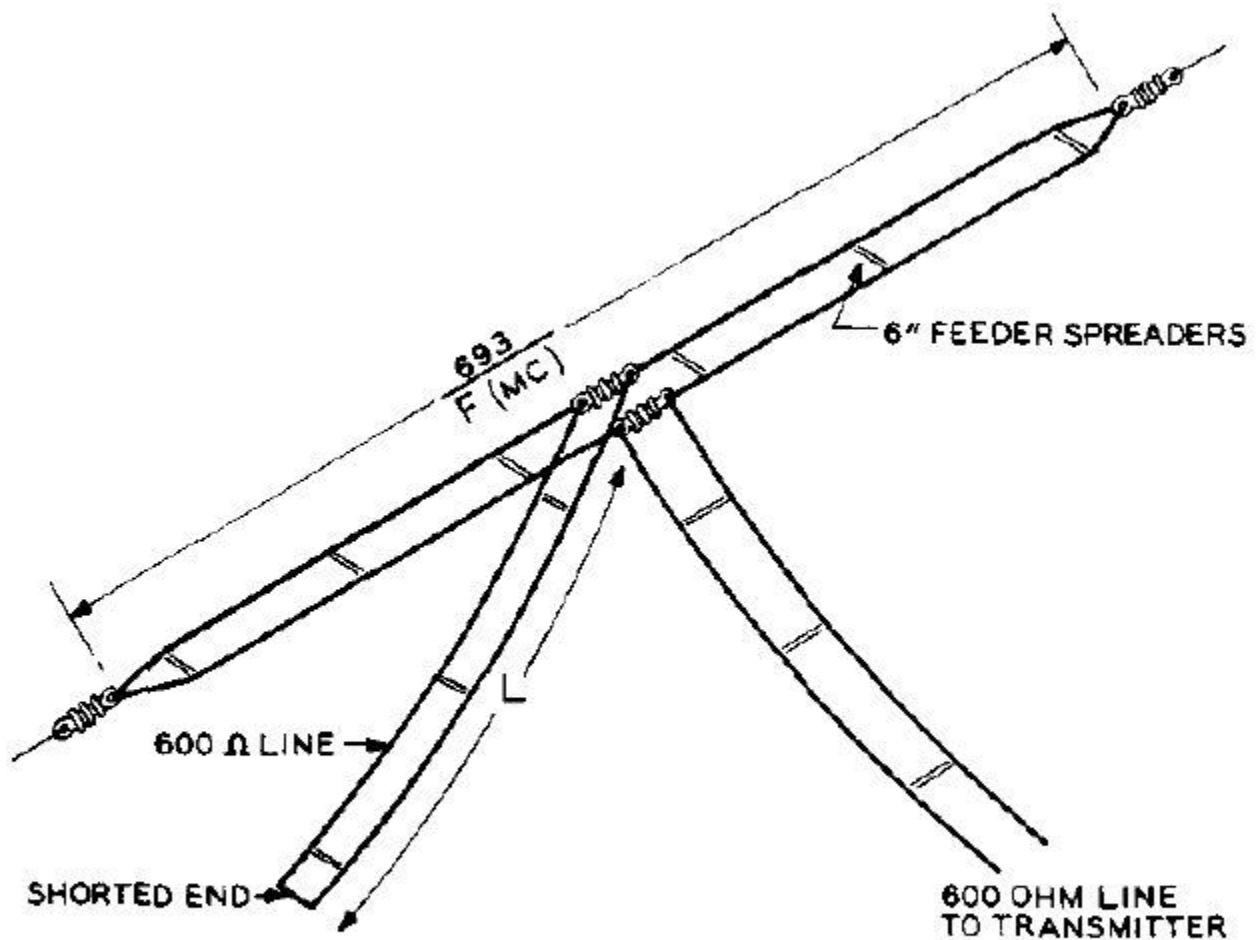

$L = 67 \text{ FT. WHEN ANTENNA IS } 195 \text{ FT.}$
 $L = 33 \text{ FT. " " " } 98 \text{ FT.}$
 $L = 16.5 \text{ FT. " " " } 49.6 \text{ FT.}$

184 - Wideband Omni-Directional Discone Antenna

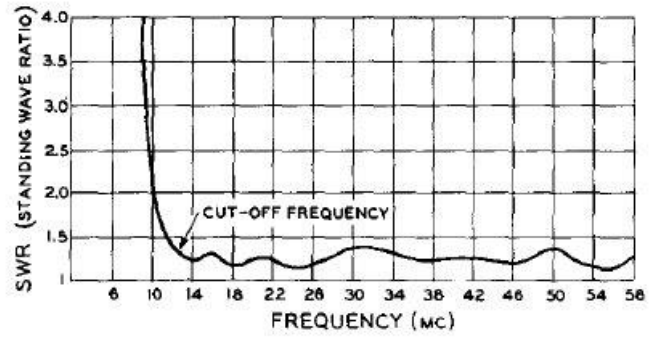
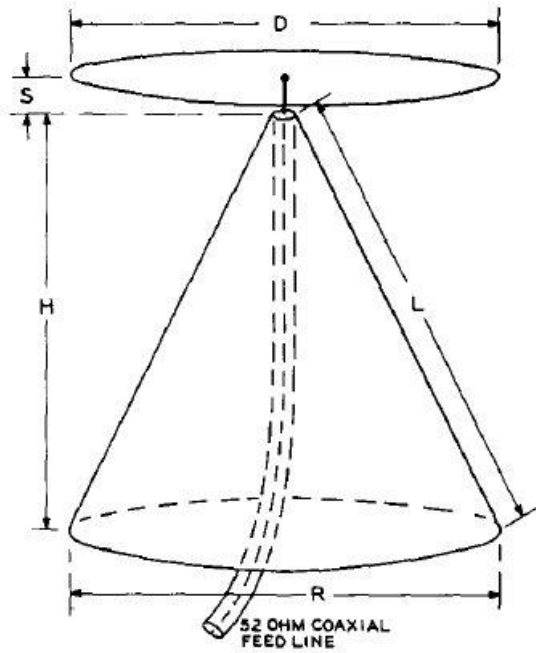

DIMENSIONS

20, 15, 11, 10, 6 METERS

D=12' L=18'
S=10" R=18'
H=15'7"

15, 11, 10, 6 METERS

D=8' L=12'
S=6" R=12'
H=10'5"

11, 10, 6, 2 METERS

D=6' L=9'8"
S=4" R=9'6"
H=8'3"

185 - Wideband Rhombic Antenna for 40m to 10m

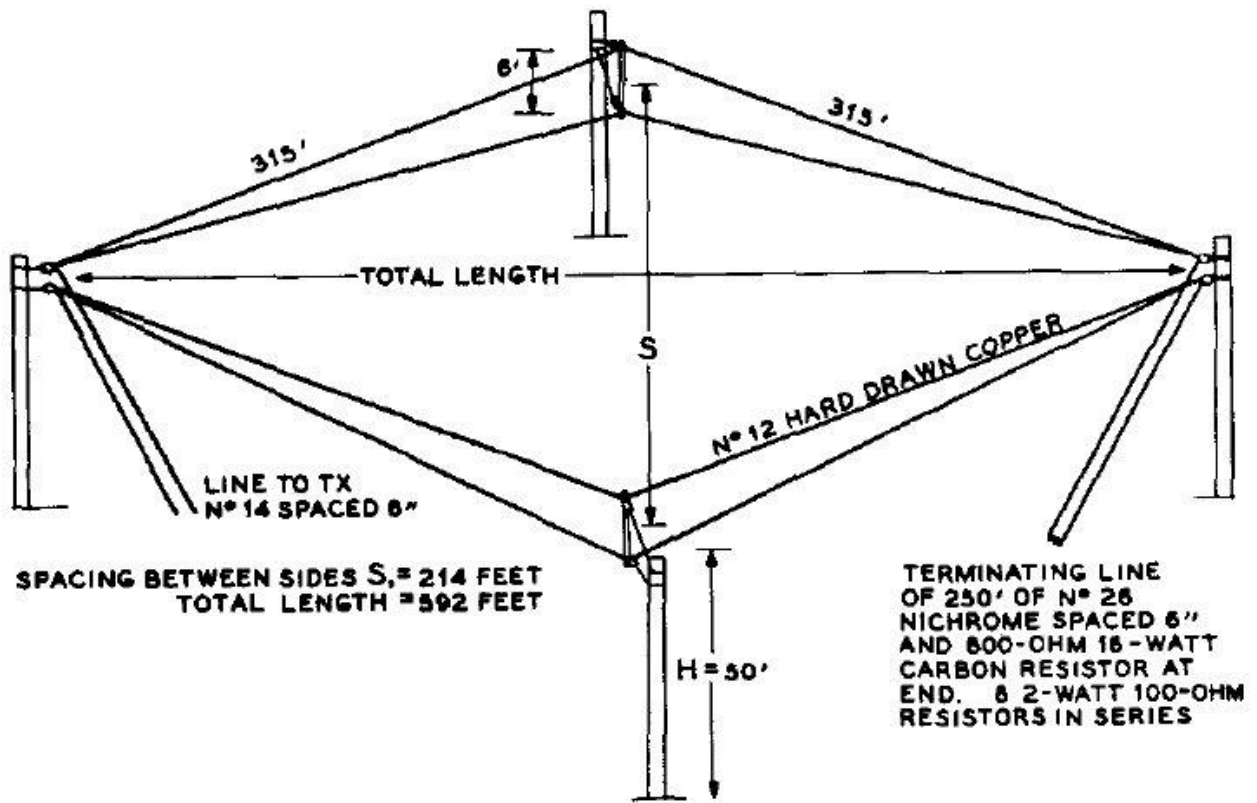

186 - Pre-Cut Linear Array Antenna 3dB-Gain for 40m

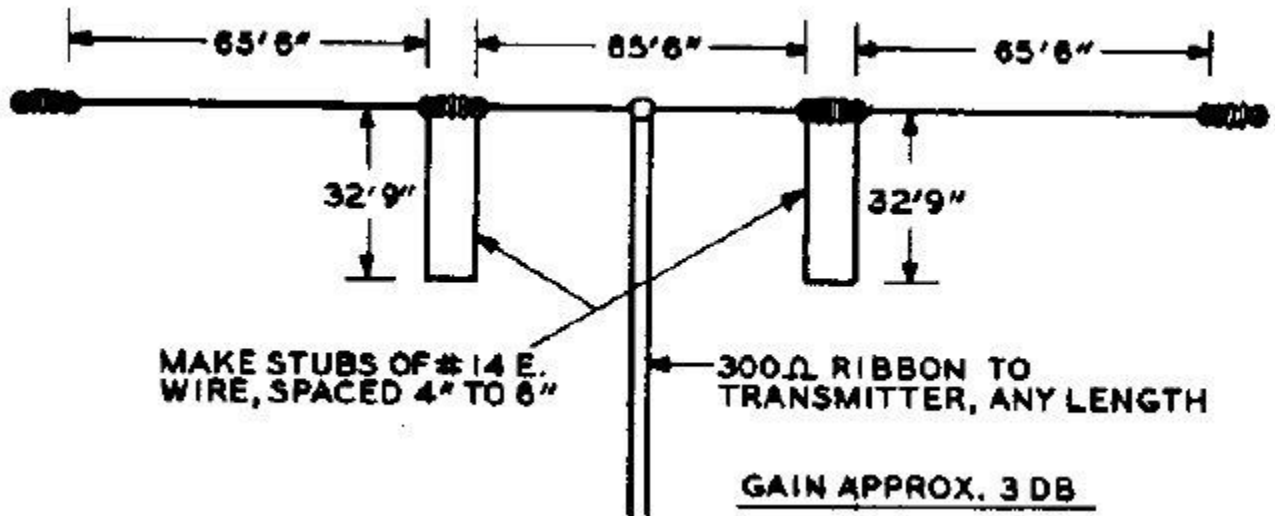

187 - X-Array Antenna 6dB-Gain for 20m, 15m, 10m

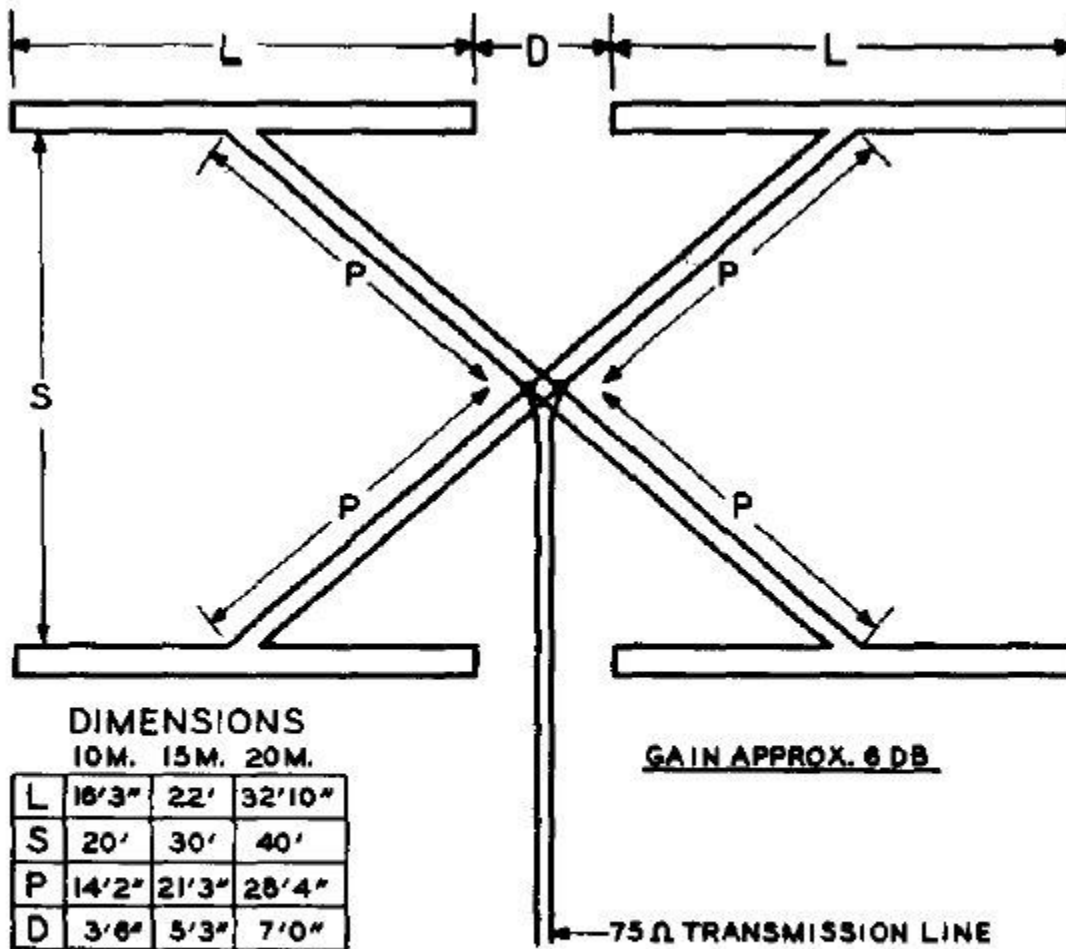

The entire array (with the exception of the 75-ohm feed line) is constructed of 300-ohm ribbon line. Be sure phasing lines (P) are poled correctly, as shown.

188 - Double-Bruce Array Antenna 5dB-Gain for 20m, 10m

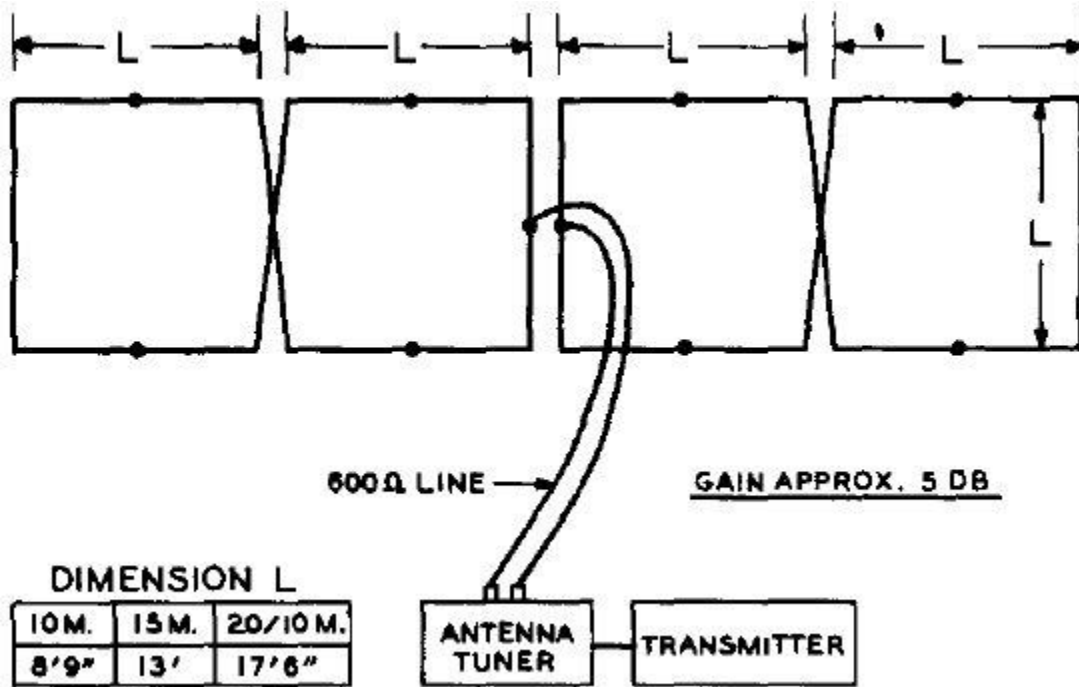

189 - Bi-Square Broadside Array Antenna 4dB-Gain for 20m, 15m, 10m

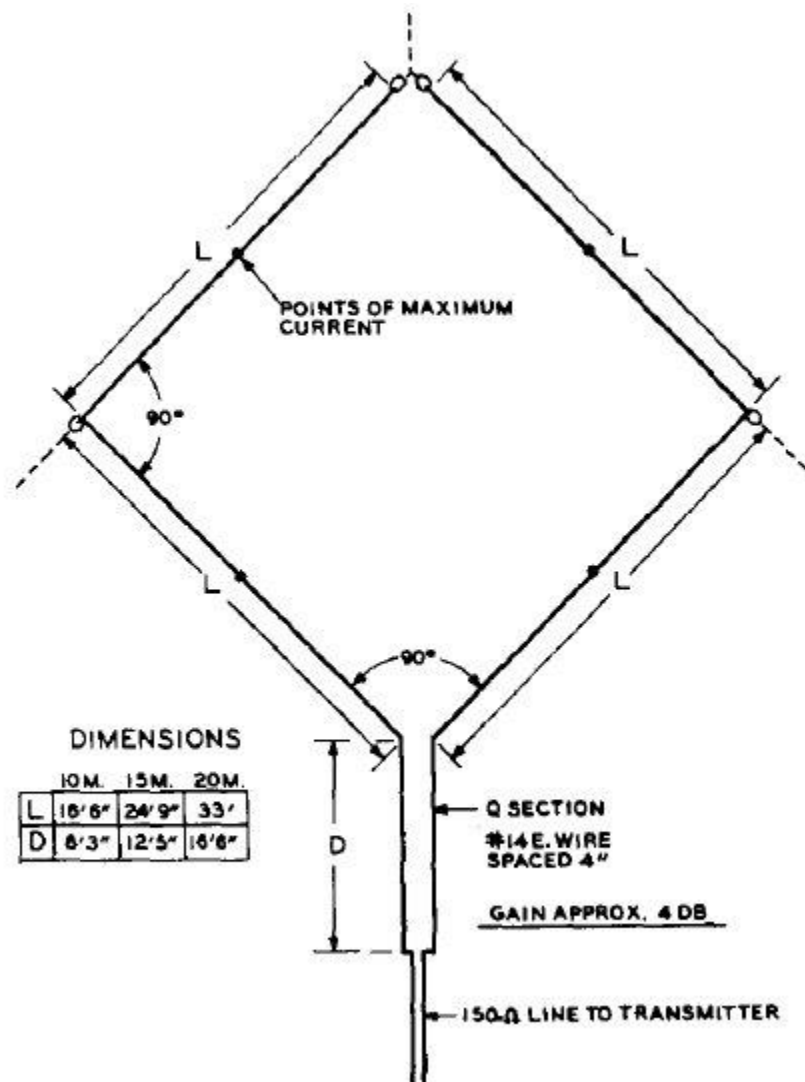

190 - Six-Shooter Broadside Array Antenna 7.5dB-Gain for 20m, 15m, 10m

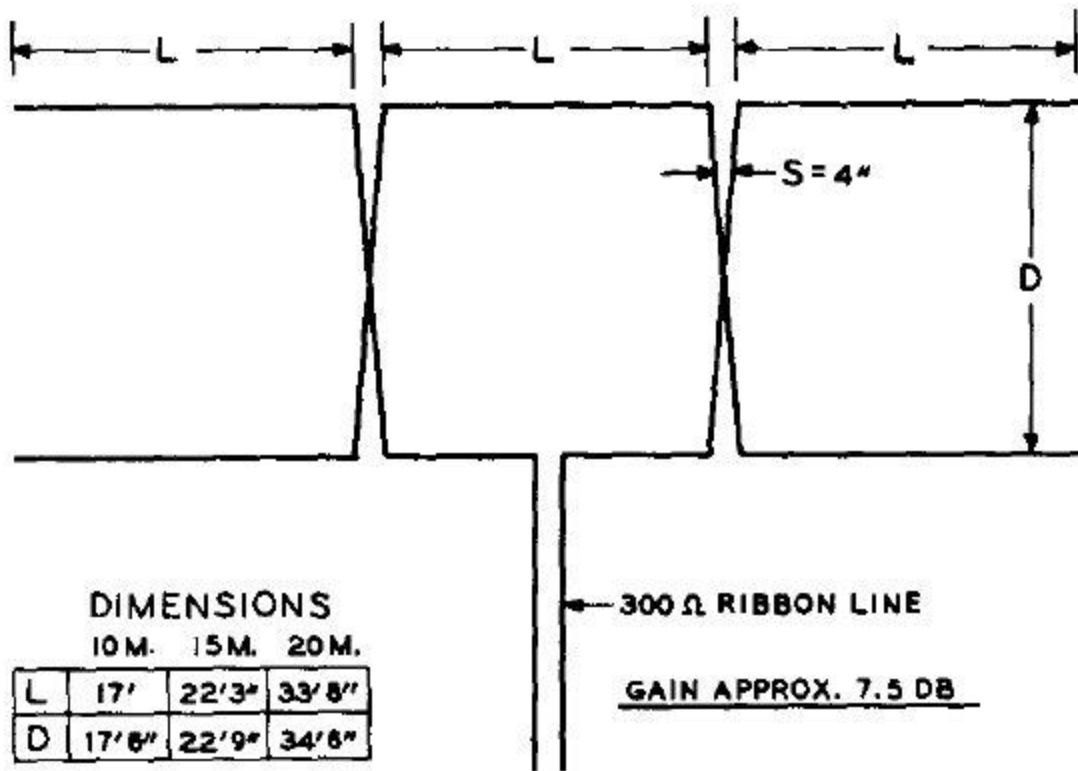

191 - Triplex Flat-Top Beam 4.5dB-Gain for 20m, 15m, 10m

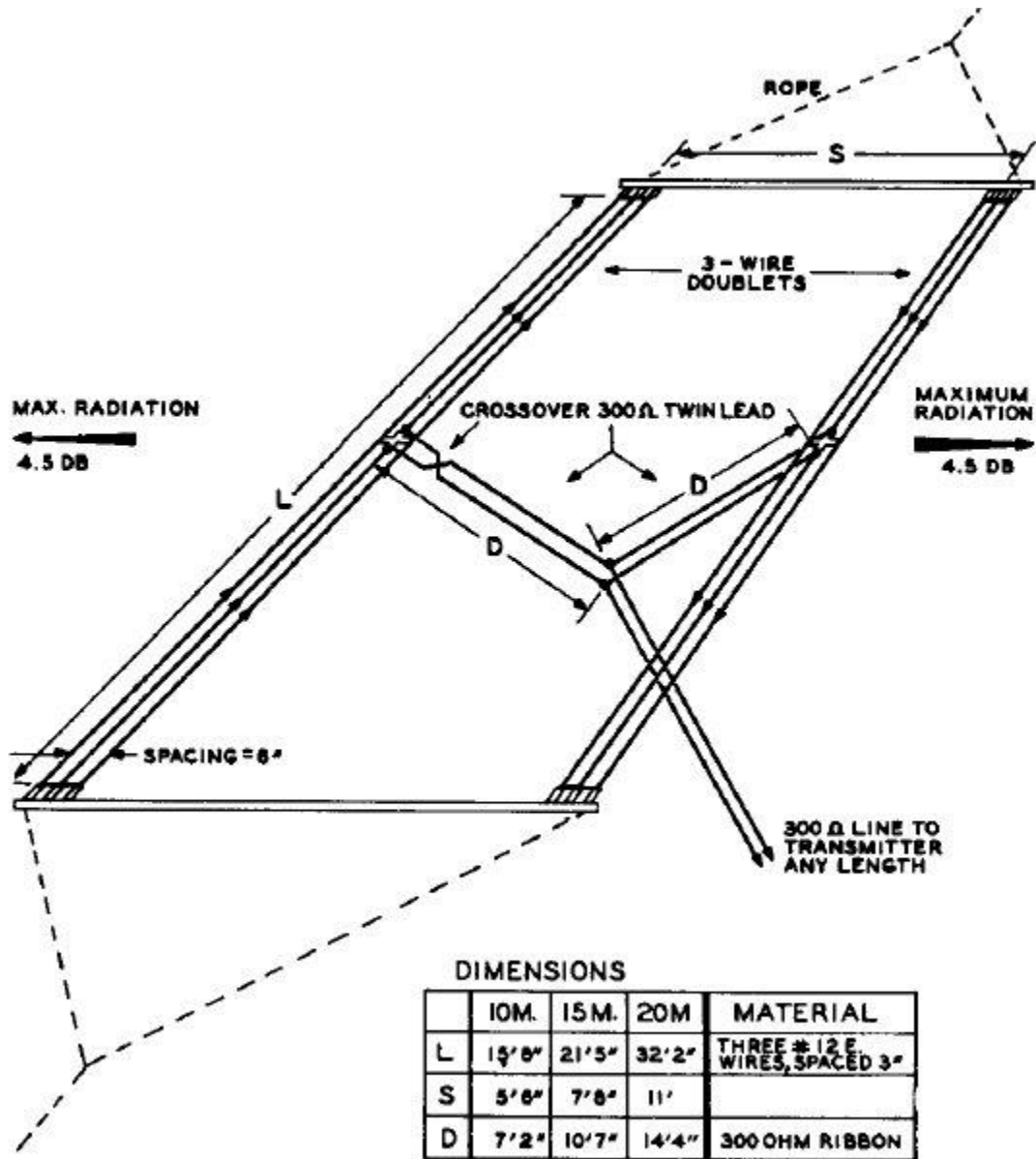

192 - Dual-Band Tilt Antenna for 20m, 10m

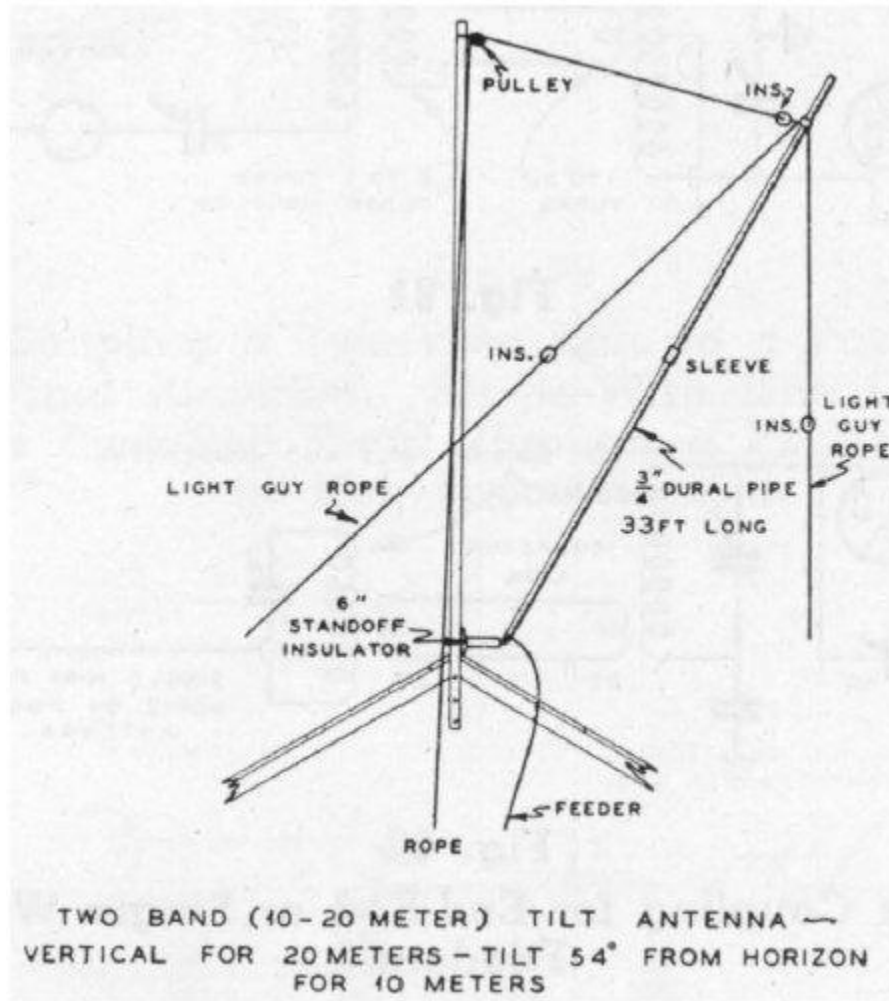

193 - Super Space Multiband Dipole Antenna for 80m to 10m

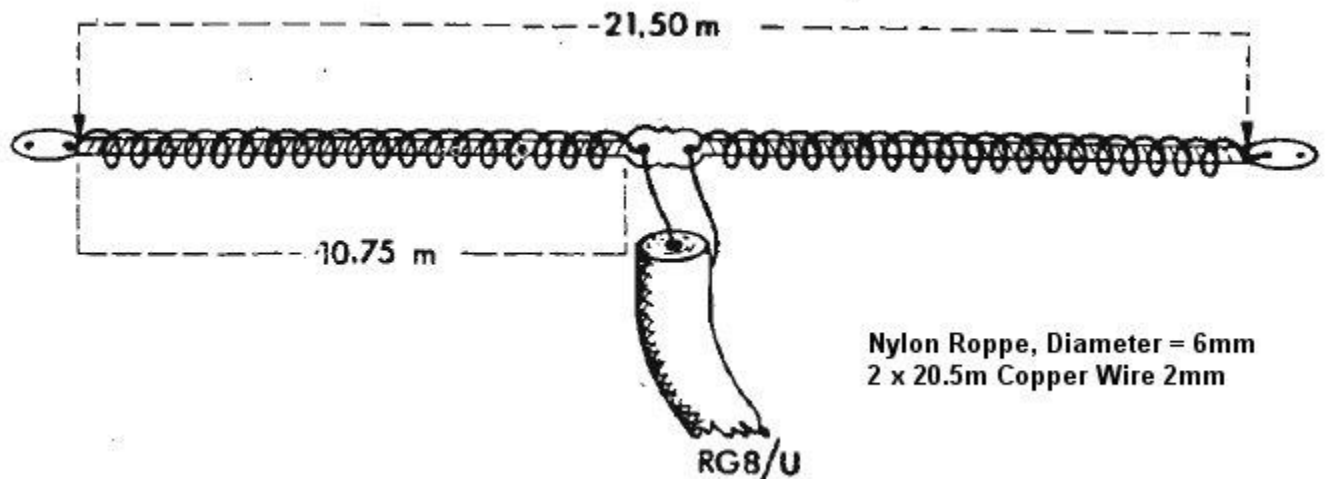

194 - Bi-Square Beam Antenna Gain=5.5dB for 10m

Feed at AF = Horizontal Polarization
Feed at E = Vertical Polarization

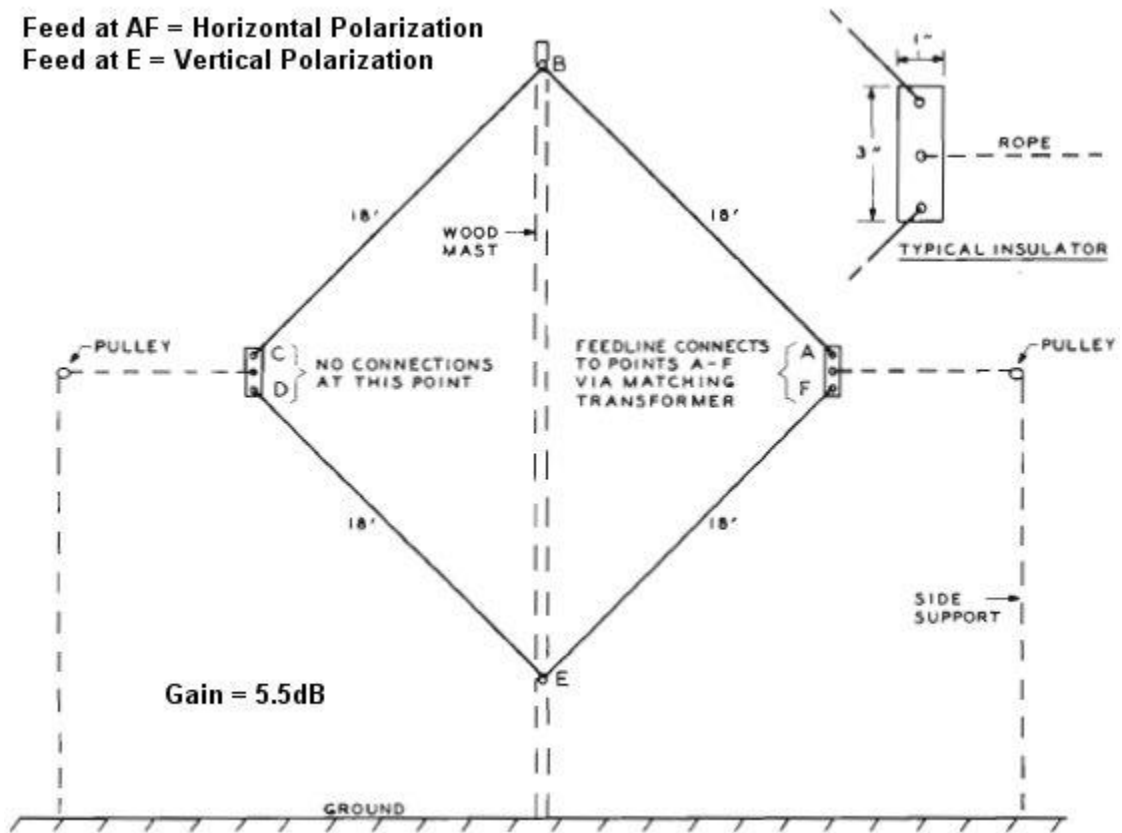

195 - Cousin of G5RV Multiband Antenna for 40m to 10m

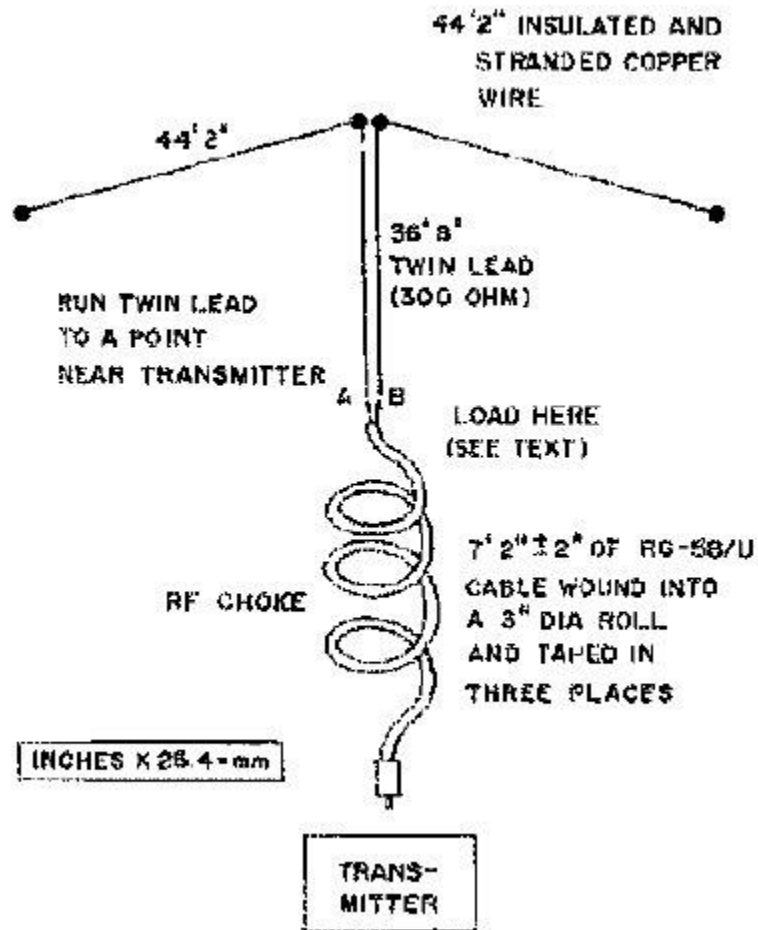

196 - Cayman Quad Antenna for 20m

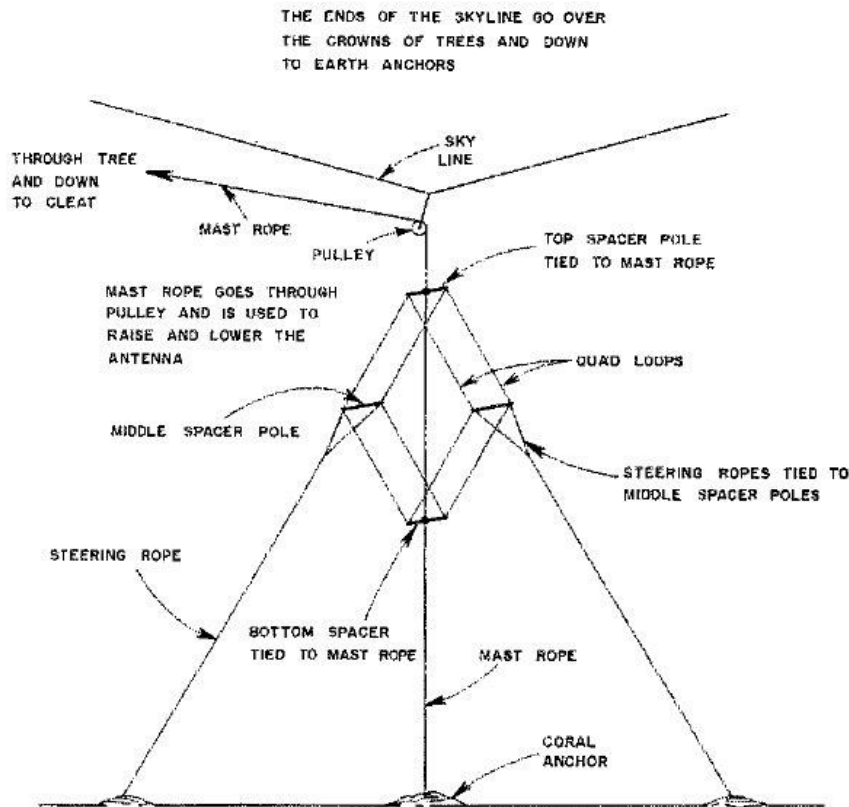

Length of one side of driven radiator: $250/f = 17.86$ ft.
 Length of one side of closed reflector: $258/f = 18.43$ ft.
 Spacing between loops: $118/f = 8.43$ ft.

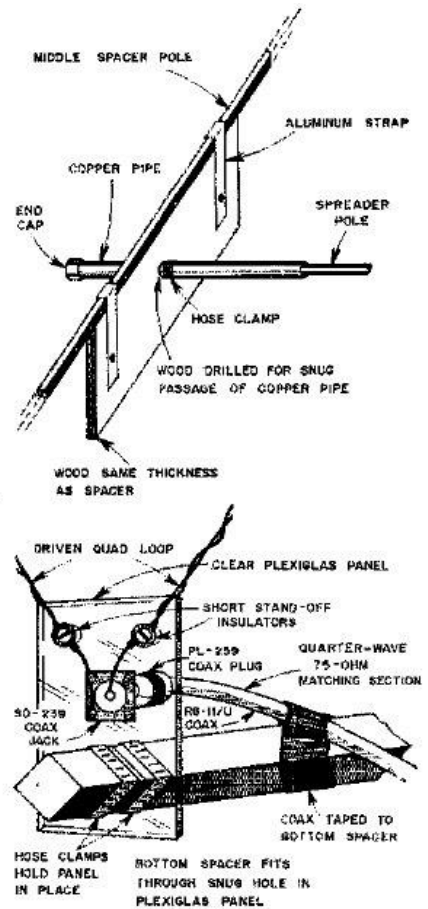

197 - Hentenna Gain=3dB with Bazooka Match for 6m

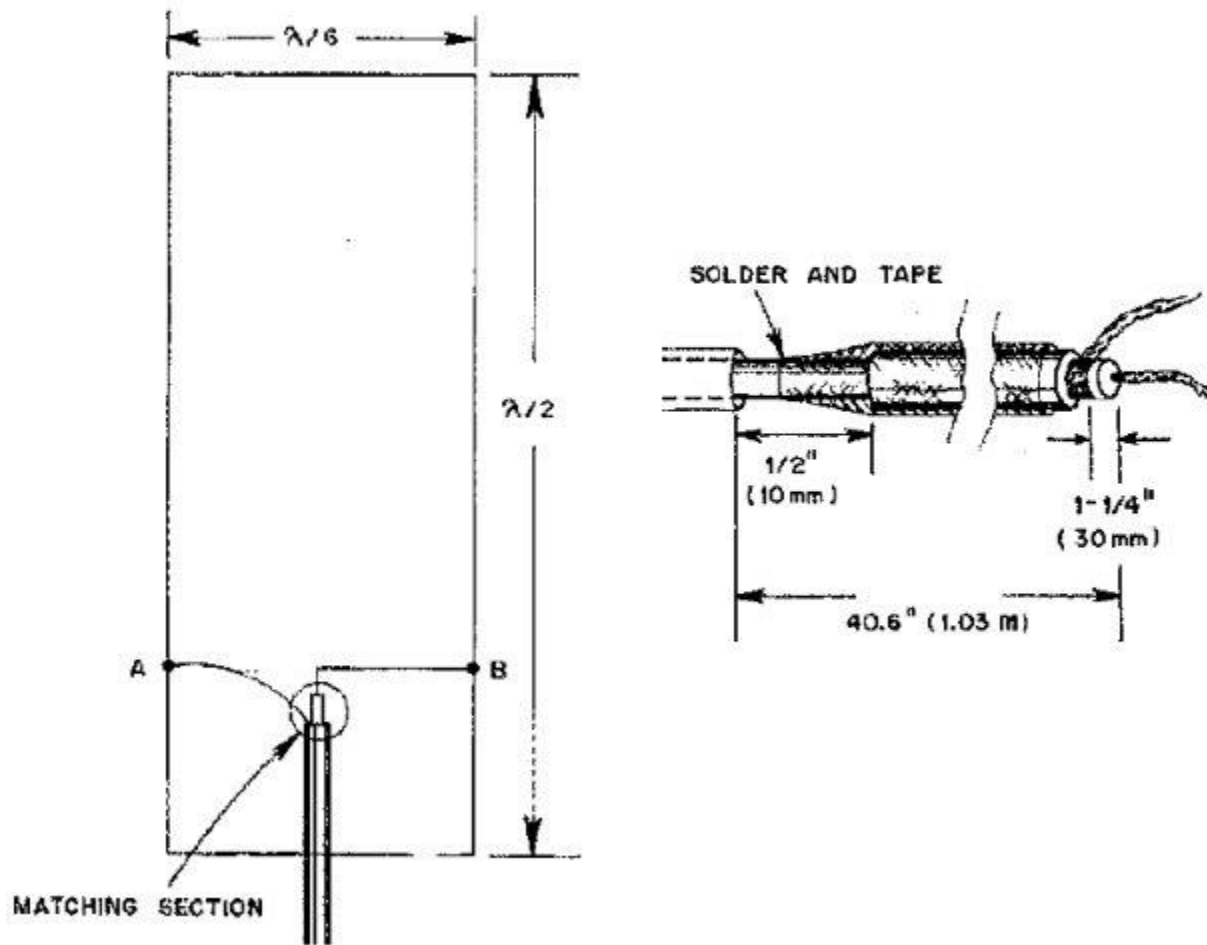

198 - X-Beam Antenna Gain=3dB for 20m

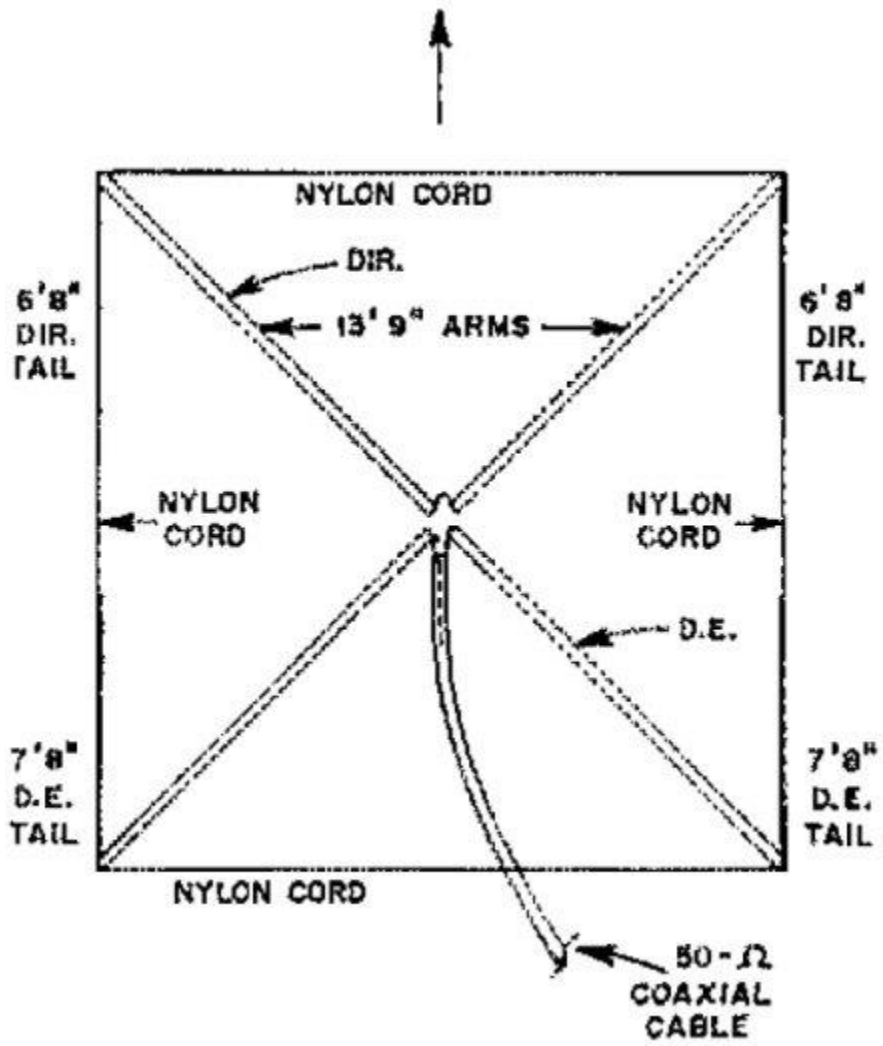

199 - Twin Delta Loop Antenna Gain=6dB for 160m, 80m, 40m

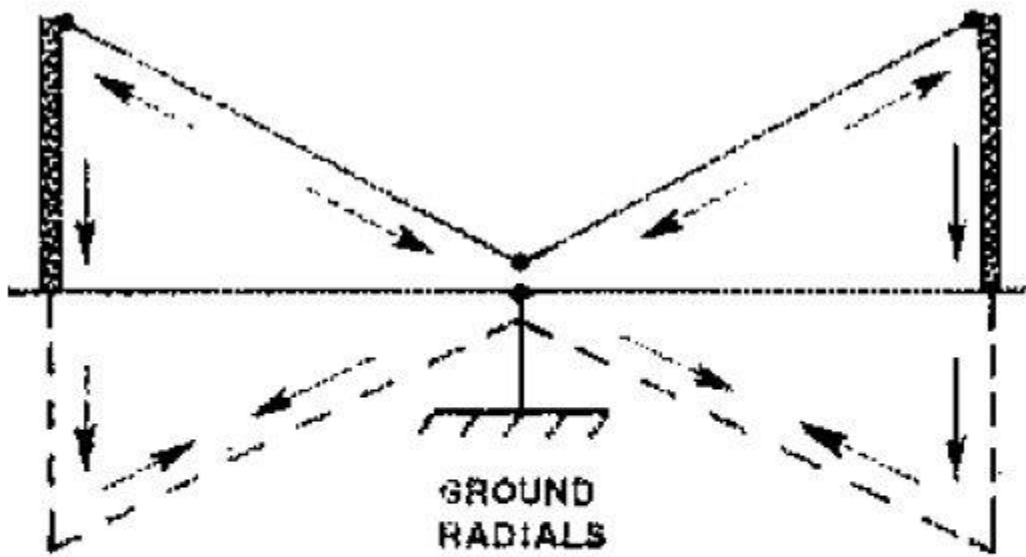

Twin- Delta Loop, with the Image in the ground plane.

<i>Band</i>	<i>Tower Height (ft)</i>	<i>Length of Sloping Wires (ft)</i>
160 m ^t	102.03	204.06
80 m	49.66	99.72
40 m	25.92	51.84

200 - Inverted-V Beam Antenna for 30m

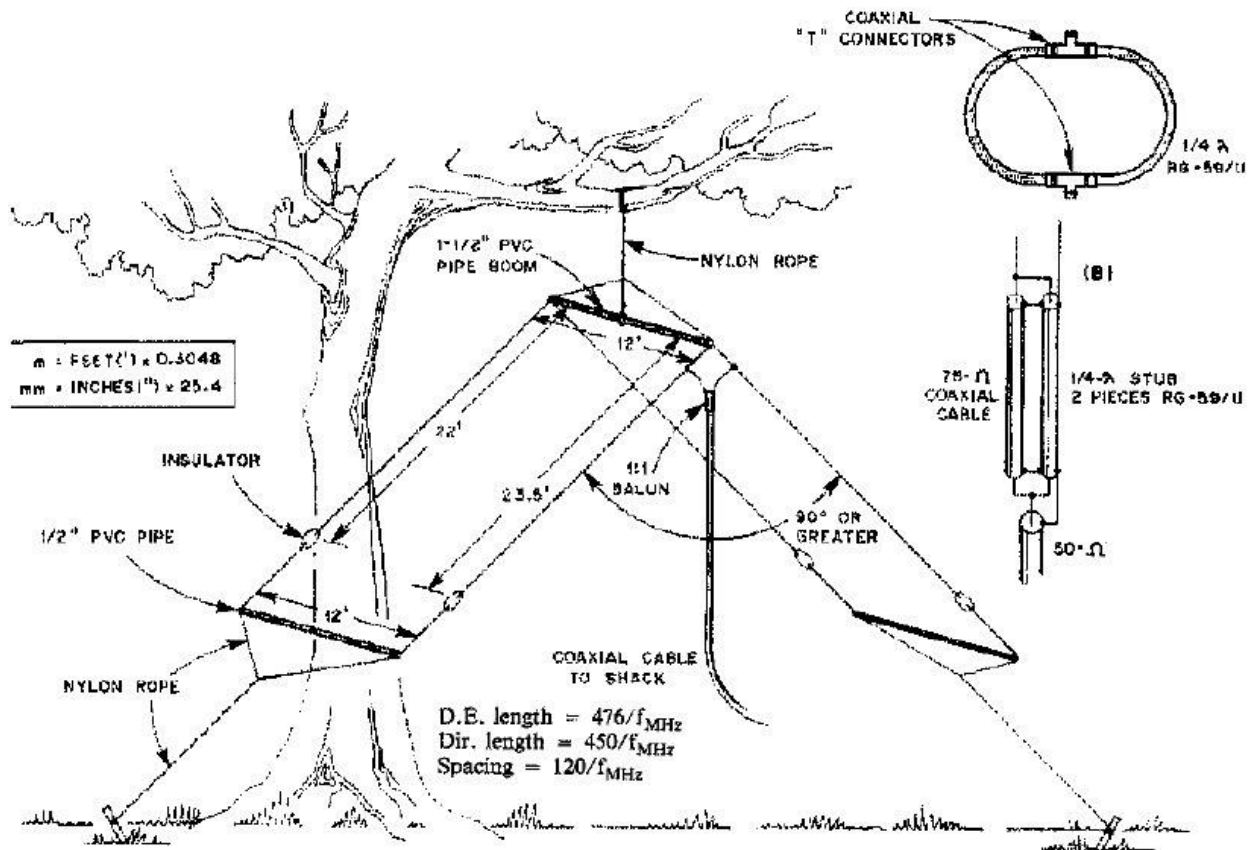

References:

- Antenna Toolkit - J. Carr*
- Practical Antenna Handbook - J. Carr*
- More Antenna Classics - C. Hutchinson*
- Amateur Radio Techniques - P. Hawker*
- The Radio Handbook - W. Orr (editor), 15th edition*
- The Radio Antenna Handbook - Engineering Staff of "Radio"*
- Jones Antenna Handbook - Frank C. Jones*
- ARRL Antenna Handbook 1990-2007*
- ARRL Handbook 1937-2009*
- ARRL Antenna Compendium*
- 73 Magazine 1970-2002*
- Funkamateur Magazine 1990-2011*
- RSGB Handbook - 2007 - 2010*
- QST Magazine - 1980 - 2010*